

**RESISTA**[®]
www.resista.it

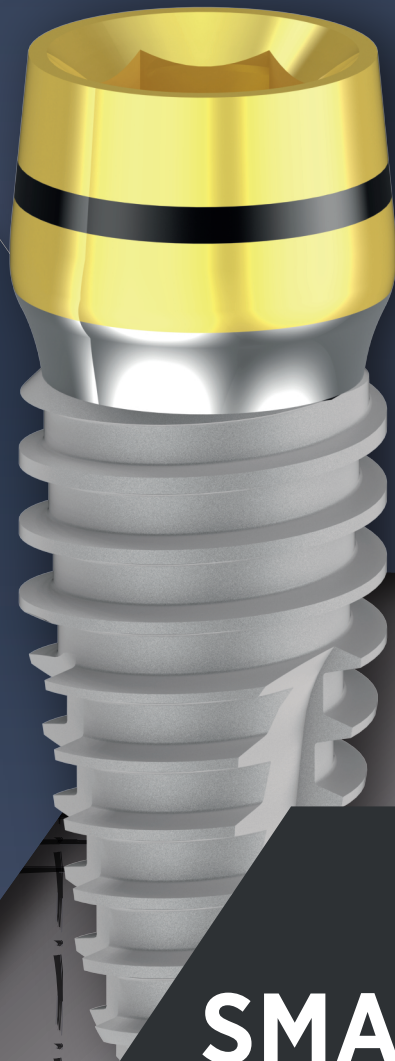

SMART SURGERY

index

●	Profilo Aziendale - Company Profile	02
●	Macro Geometrie - Macro Geometry - <i>Panoramica sulle tipologie di impianti</i>	10
●	Micro Geometrie - Micro Geometry - <i>Trattamento della Superficie</i>	16
●	Pro MSD Tecnologia di Fresaggio - Pro MSD Drilling Technology	20
●	Esagono Interno IK - Internal Hexagon IK Tapered Shape	23
●	Esagono Interno IA - Internal Hexagon IA Active Blade Shape	39
●	Esagono Interno IC - Internal Hexagon IC Cylindrical Shape	51
●	Protesica Universale IP Esag. Interno - Internal Hex IP Universal Prosthetics	59
●	Esagono Interno IK ONETIME - Internal Hexagon IK ONETIME	83
●	Morse Interno IK Narrow 29 - Internal Morse IK Narrow 29 Tapered Shape	95
●	Esagono Interno IC 30 Narrow - Internal Hexagon IC 30 Cylindrical Shape	101
●	Morse 5° Interno IBK Oneseal - 5° Internal Morse IBK Oneseal	111
●	Morse 5° Interno BANP - 5° Internal Morse BANP	121
●	Esagono Esterno EC - External Hexagon EC Cylindrical Shape	141
●	Esagono Esterno EK - External Hexagon EK Tapered Shape	149
●	Esagono Esterno ES - External Hexagon ES Tapered Shape	161
●	Conical C. 12° IK Platinum - 12° Conical C. IK Platinum NARROW	179
●	Conical C. 12° IA Platinum - 12° Conical C. IA Platinum NARROW	183
●	Conical C. 12° ES Platinum - 12° Conical C. ES Platinum NARROW	187

index

●	Conical C. 12° IK Platinum - 12° Conical C. ES Platinum REGULAR	197
●	Conical C. 12° IA Platinum - 12° Conical C. ES Platinum REGULAR	201
●	Conical C. 12° ES Platinum - 12° Conical C. ES Platinum REGULAR	205
●	UNI-Q-MUA Impianto Monofasico - One Piece Implants UNI-Q-MUA	215
●	Micro Impianti MS - One Piece Implants Micro Implants	227
●	Viti di Ricambio e Mounters - Spare Screws & Mounters	231
●	Strumentario e Frese Chirurgiche - Instruments & Drills	235
●	Chirurgia Computer Guidata - Computer Guided Surgery	241
●	Kit Chirurgici - Surgical Kits	250
●	Protesica & Overdenture - Overdenture & Prosthetics Attachments	253
●	Strumenti & Accessori Chirurgici - Instruments & Surgical Tools	261
●	Kit Mini Rialzi per via Crestale - Mini Sinus Lift Kit	268
●	Impianti Pterigoidei e Nasali - Pterygoids and Nasal Implants	269
●	Strumenti Chirurgici Accessori - Instruments and Surgery Tools	270

company profile



RESISTA®

Marchio di proprietà della **Ing. Carlo Alberto ISSOGLIO & C. S.r.l.** identifica l'intera gamma di prodotti concepiti dall'azienda per soddisfare le esigenze di odontoiatri ed odontotecnici.

since 1946

RESISTA è sinonimo di garanzia, equilibrio e continuità, noto in tutto il mondo.



RESISTA, trademark owned by Ing. Carlo Alberto Issoglio & C. S.r.l. , identifies the full range of products designed by the company to meet the needs of dentists and dental technicians.

RESISTA is known all over the world since 1946, and synonymous of guarantee, balance and continuity.

company profile

L'azienda dispone di un complesso produttivo per la realizzazione di dispositivi medici, tra i più moderni del settore, situato ad Omegna, una bellissima cittadina che si affaccia sul Lago d'Orta.

Con impegno, vanto ed orgoglio, il personale tecnico e scientifico del reparto Ricerca & Sviluppo è quotidianamente dedicato a promuovere l'innovazione ed il miglioramento dei nostri prodotti e processi.



Negli anni, il marchio **RESISTA** è diventato anche sinonimo di risposta rapida e qualitativa ai cambiamenti del mercato e alle esigenze dell'odontoiatria moderna.

Qualità, Prezzo e Servizio riassumono in tre semplici parole la percezione quotidiana degli utilizzatori dei prodotti marchiati **RESISTA**.



The company has one of the most ip-to-date manufacturing site for the medical devices, located in Omegna, a beautiful town on Orta Lake, Italy.

With commitment, merit and pride, the technical and scientific staff of the R&D department is daily involved to promote innovation and the improvement of our products and processes.

Over the years, the **RESISTA** brand has also become synonymous of fast and qualitative response to market changes and the needs of modern dentistry.

Quality, Price and Service summarize in three simple words the daily perception of the users of **RESISTA** branded products.

the choice

RICERCA & SVILUPPO - Il programma R&D di Resista Group nasce dalle indicazioni provenienti dal mondo clinico unite alla nostra esperienza maturata nel campo dei dispositivi medici impiantabili.

Con l'utilizzo di programmi di modellazione 3D e sofisticati sistemi computerizzati simuliamo le geometrie finali ed il design, sviluppando le fasi di prototipizzazione rapida dei progetti.



INNOVAZIONI - Resista Group è strutturata per soddisfare tutte le esigenze del metal-implant con una avanzata tecnologia di concezione, prototipizzazione ed ingegnerizzazione finale del prodotto per arrivare a soluzioni innovative.

La validazione viene eseguita in collaborazione con Istituti di Ricerca accreditati in conformità ai requisiti degli Standard Internazionali.



RESEARCH & DEVELOPMENT - The R&D Resista Group's program stems from indications from the clinical world combined with our experience in the field of implantable medical devices.

Due to the use of 3D modeling programs and sophisticated computer systems, we simulate the final geometries and the design, developing the rapid prototyping phases of the projects.

INNOVATIONS - Resista Group is structured to meet all the needs of the metal-implant with an advanced conception technology, prototyping and final product engineering to arrive at innovative solutions. Validation is carried out in collaboration with accredited Research Institutes following the International Standards Requirements.

the choice

QUALITÀ DI PROGETTO E PROCESSO - ICIM Spa ha certificato la **Ing. C. A. Issoglio & C. S.r.l.** in accordo alle normative **UNI EN ISO 9001** e **UNI EN ISO 13485** nel rispetto di tutte le normative vigenti relative ai prodotti e servizi offerti.

Ogni dipendente che ricopre differenti ruoli (tecnici, ingegneristici, amministrativi, commerciali, operatori meccanici, ecc), segue linee guida ed obiettivi per un unico fine: il miglioramento continuo.



OBIETTIVO PRINCIPALE - La soddisfazione del cliente è il nostro obiettivo. Il fattore vincente è la capacità dell'azienda a risolvere nel breve qualsiasi tipo di richiesta.

Il supporto tecnico fornito dagli specialisti di prodotto, la disponibilità, l'efficienza e la cordialità sono il punto di forza della nostra struttura.



PROJECT AND PROCESS QUALITY - ICIM Spa certified **Ing. C. A. Issoglio & C. S.r.l.** in accordance with **UNI EN ISO 9001** and **UNI EN ISO 13485** in compliance with all current regulations relating to the products and services offered. Every employee covering different roles (technical, engineering, administrative, commercial, mechanic operators, etc.), follows guidelines and objectives for a single purpose: continuous product improvement.

MAIN OBJECTIVE - Customer satisfaction is our objective. The winning factor is the company's ability to quickly resolve any type of request. The technical support provided by Product Specialists, availability, efficiency and friendliness are the strengths of our structure.

the project

CONCETTI BIOMECCANICI - Il successo della metodica implantare **Resista Group** è frutto di approfonditi studi sul design dei prodotti e sulla tecnologia di produzione. I risultati clinici a lungo termine sono, infatti, fortemente influenzati dalla precisione e dalla qualità.

Il **processo produttivo** viene eseguito da operatori altamente qualificati che, con l'ausilio dei sistemi elettronici CNC automatizzati, riescono ad ottenere risultati ottimali e riproducibili.



Le tolleranze di lavorazione, soprattutto negli **accoppiamenti protesici**, sono il nostro **gold standard** e vengono confinate tra i **7 - 10 μm** .

MATERIALI - Gli impianti sono realizzati in **Titanio ASTM Gr 4 Cold Worked** (Norm. ISO 5832/2), le viti di ritenzione e le componenti protesiche sono realizzate in **Lega di Titanio ASTM Gr 5 ELI** (Norm. ISO 5832/3).



BIOMECHANICAL CONCEPTS - The **Resista Group** method success is the result of several product design studies and the high technology applied in the production. The precision and reliability of the implant has a strong influence on the long term clinical success.

The **manufacturing process** is carried out by high qualified operators, skilled enough to obtain optimal and reproducible results with the use of electronically controlled CNC machinery. The machinery tolerances, especially in **prosthetic connections**, are our **gold standard** and they are made between **7 - 10 μm** .

MATERIALS - The implants are made in **Titanium ASTM Gr.4 Cold Worked** (ISO 5832/2), the prosthetic screws and the prosthetic components are made in **Titanium ASTM Gr.5 ELI** (ISO 5832/2).

the project

TRATTAMENTI DI SUPERFICIE - Il processo di micro-sottrazione non contaminata, doppia acidificazione **DAE** (Double Acid Etching), modifica la micro rugosità degli impianti (**Ra, Rq**) texturizzando la superficie e massimizzando la bagnabilità ed il biomimetismo.

Il trattamento di superficie ed il processo di decontaminazione, brevettati da **Nobil Bio Ricerche**, sono in grado di migliorare le proprietà bio-chimiche degli impianti dentali **Resista**.

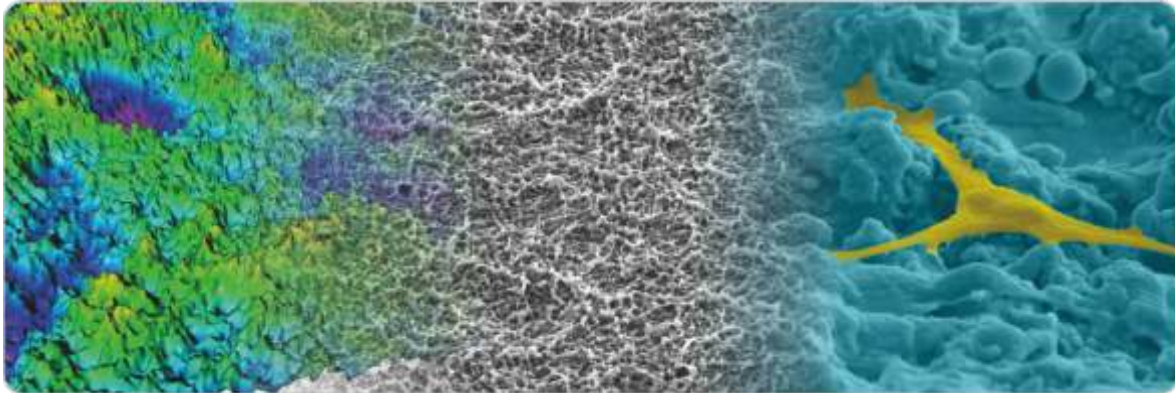

SISTEMA QUALITÀ - L'azienda è certificata in accordo alle norme **UNI EN ISO 9001** e **UNI EN ISO 13485** e ha ottenuto la marcatura **CE** sui propri dispositivi medici in accordo alla Direttiva Europea 93/42/CEE e ss.mm.ii. nel rispetto delle armonizzate di riferimento.

L'impegno è costante nel mantenimento della conformità.



SURFACE TREATMENTS - The non-contaminant micro-subtraction process, **DAE** (Double Acid Etching), changes the implant micro roughness (**Ra, Rq**) and the surface texture maximizing the wettability and biomimetic properties. The new surface treatment and decontamination process are patented by **Nobil Bio Ricerche** improving the bio-chemical properties of the implants.

QUALITY SYSTEM (QS) - **UNI EN ISO 9001** and **UNI EN ISO 13485** in compliance of Medical Devices Directives. We are qualified in the design and in the production management of dental implants, dental prosthesis, intraligamental anesthesia syringes and abrasive discs.

mounter - transfer - abutment - CGS

MOUNTER PREASSEMBLATO IN TITANIO GR 5 - Uno dei punti di forza della nostra linea **Resista** è il Dispositivo di Montaggio Multifunzione che viene utilizzato nelle **4** differenti applicazioni:

1 Prelievo ed avvitamento dell'impianto - **2** Transfer per impronta Closed Tray - **3** Abutment definitivo fino a 13° di correzione angolare - **4** Mounter per Chirurgia Computer Guidata

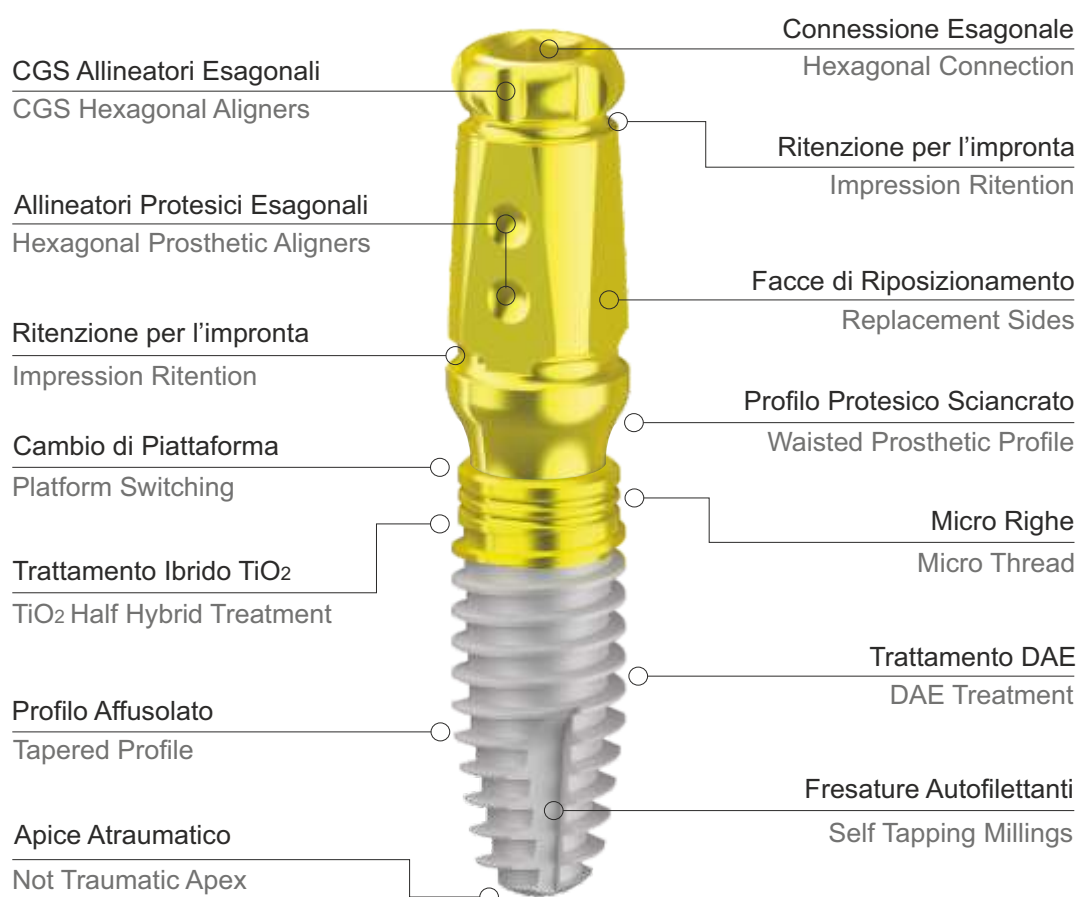

TITANIUM GR 5 PRE-ASSEMBLED MOUNTER - One of the strong points of our **Resista** line is the Multifunction Mounter Device that is used in the **4** following different applications:

1 Implant pick up and screwing - **2** Closed Tray Impression Transfer - **3** Definitive Abutment up to 13° angular correction - **4** Mounter for Computer Guided Surgery

mounter - transfer - abutment - CGS

MOUNTER TRANSFER - Transfer per la tecnica di impronta a **Strappo con Cucchiaino Chiuso**.

È una tecnica semplice, veloce ed efficace, adatta a tutte le tipologie di progetto protesico. Il Mounter Transfer è riposizionabile nell'impronta in un'unica posizione, definita dalle differenti facce e ritenzioni distribuite sulla superficie.

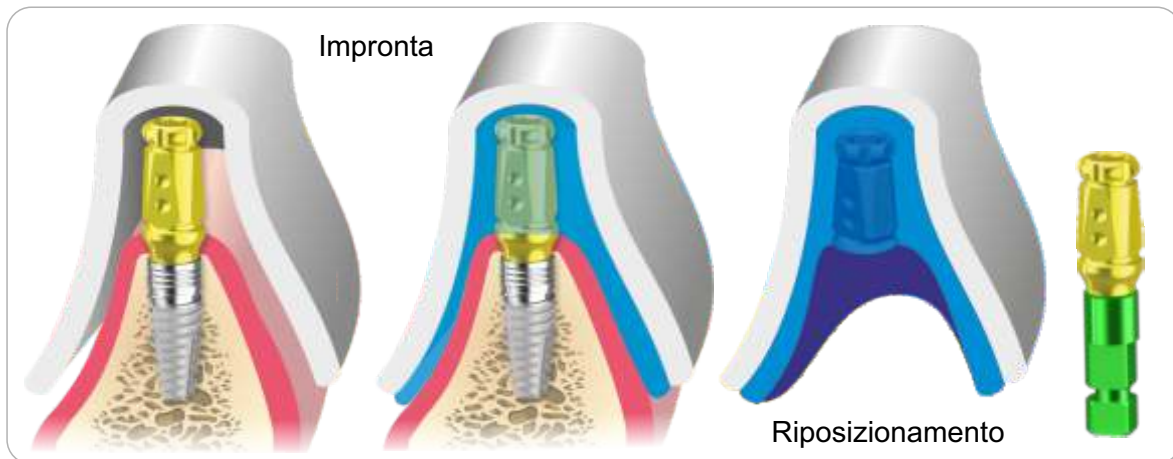

MOUNTER ABUTMENT - Moncone Protesico Definitivo completo di vite passante definitiva.

Il Mounter Moncone in Titanio Gr 5 è certificato per essere utilizzato come moncone definitivo, può essere fresato in altezza ed angolazione fino ad un massimo di 13°, utilizzando frese da laboratorio per Titanio.



TRANSFER MOUNTER - Transfer for **Closed Tray Technique** (Elastic tear impression technique).

It is a simple, fast and effective technique, suitable for all types of prosthetic projects. The Transfer Mounter can be repositioned in the impression only in one position, defined by the different sides and retentions arranged on the surface.

ABUTMENT MOUNTER - Definitive Prosthetic Abutment complete with definitive through screw.

The Gr 5 Titanium Abutment Mounter is certified to be used as a permanent abutment, can be milled in height and angle up to 13°, using Titanium laboratory burs.

mounter - transfer - abutment - CGS

MOUNTER CGS - Mounter adatto per l'inserimento degli impianti in **Chirurgia Computer Guidata**.

Il diametro cilindrico del Mounter scorre in asse dentro le Boccole per Chirurgia Computer Guidata, mentre i 6 riferimenti di allineamento esagonale (tacche) stabiliscono la posizione finale.



LA CONFEZIONE - Il Mounter e l'impianto sono contenuti nella **Boccola in Titanio Gr 4** che garantisce la qualità della superficie nel tempo e durante la rimozione in fase chirurgica, evitandone la contaminazione. Il **Vetro del Flacone** è il materiale più idoneo per la conservazione delle proprietà chimiche di superficie dell'impianto in Titanio. L'impianto così non assorbe atomi di idrocarburi schermanti, rilasciati dalle confezioni plastiche quando vengono irradiate dal trattamento di sterilizzazione a Raggi Gamma o Beta.



Hydrocarbon Deposition Attenuates Osteoblast Activity on Titanium

R. Hayashi, T. Ueno, S. Migita, Y. Tsutsumi, H. Doi, T. Ogawa, T. Hanawa, and N. Wakabayashi - J Dent Res 93(7):698-703, 2014

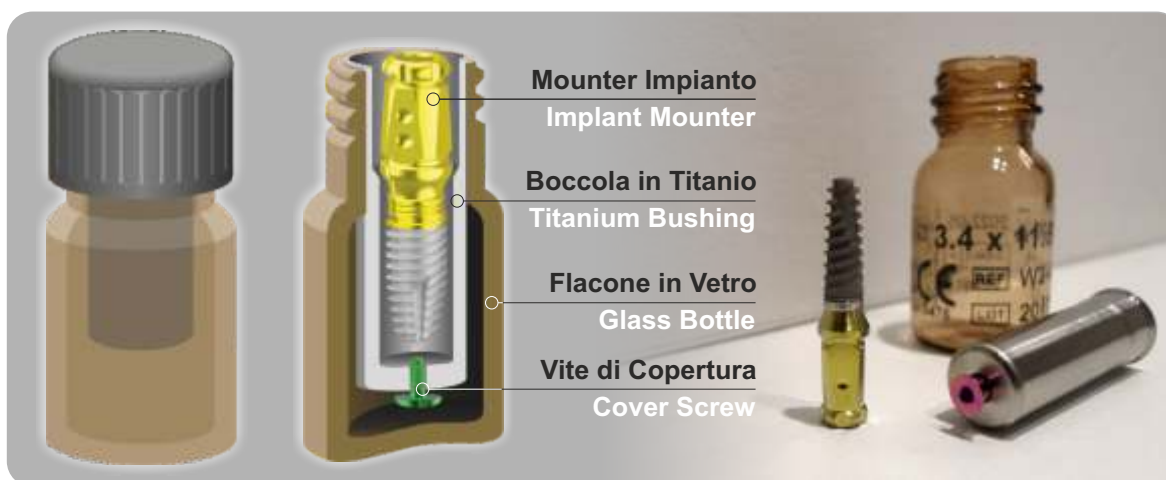

CGS MOUNTER - Mount suitable for implants placement by **Computer Guided Surgery**.

The cylindrical diameter of the Moulder glides on the axis inside the Bushings for Computer Guided Surgery, whereas the 6 hexagonal alignment reference points (notches) define the final position.

THE PACKAGING - The **Titanium Bushing** contains the Moulder and the implant and guarantees the quality of the surface during the removal surgical step, avoiding the contamination due to the scratching. The moulder and implant are contained within a **Gr. 4 Titanium Bushing**, which guarantees surface quality over time and during surgical removal, preventing contamination.

The **Glass Bottle** is the most suitable material for preserving the surface chemical properties of the titanium implant. This prevents the implant from absorbing the shielding hydrocarbon atoms, released by the plastic packaging when irradiated with Gamma or Beta rays.

macro geometry

IK tapered
FULL TREATMENT

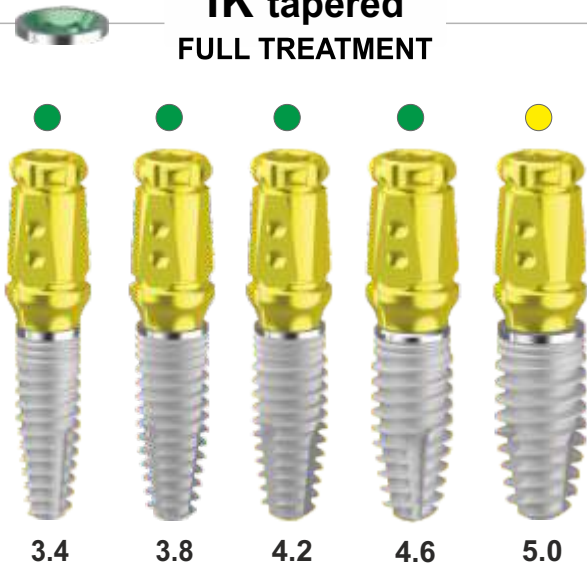

IK tapered HT
HALF TREATMENT

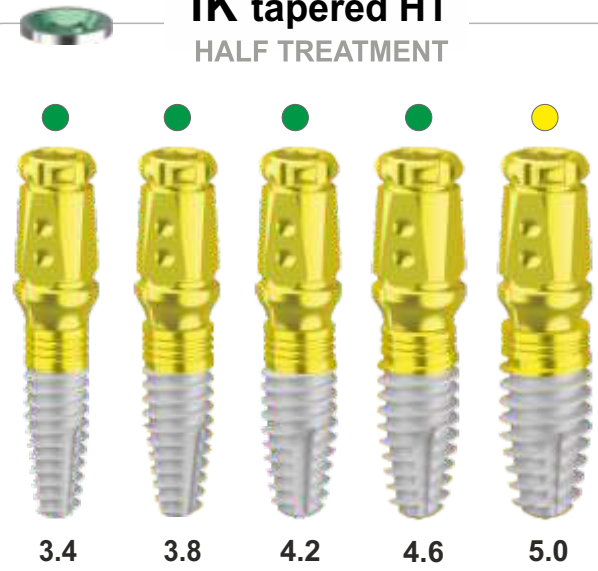

IA tapered
FULL TREATMENT

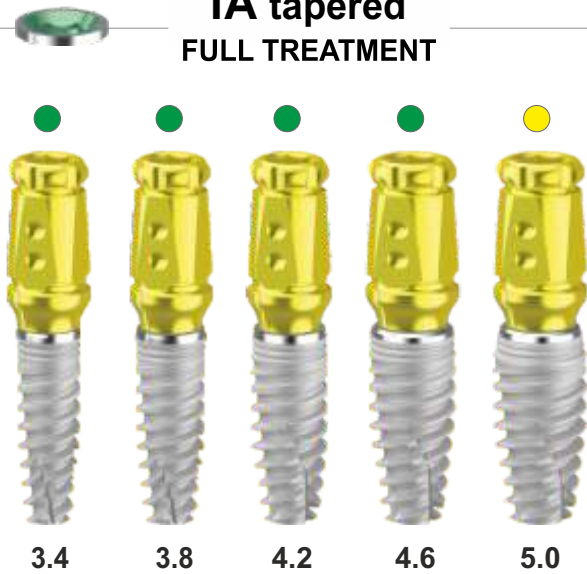

IC cylindrical
FULL TREATMENT

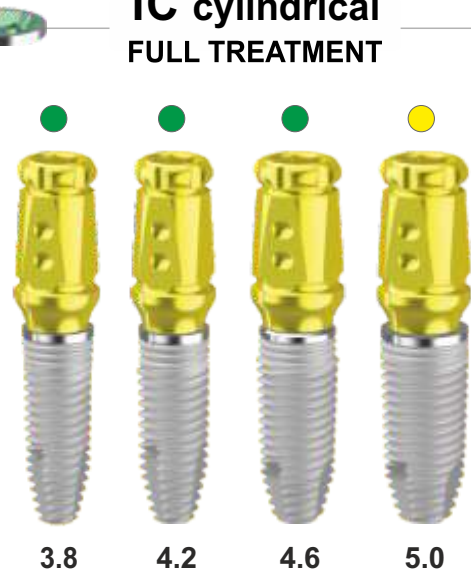

IK tapered ML
FULL TREATMENT

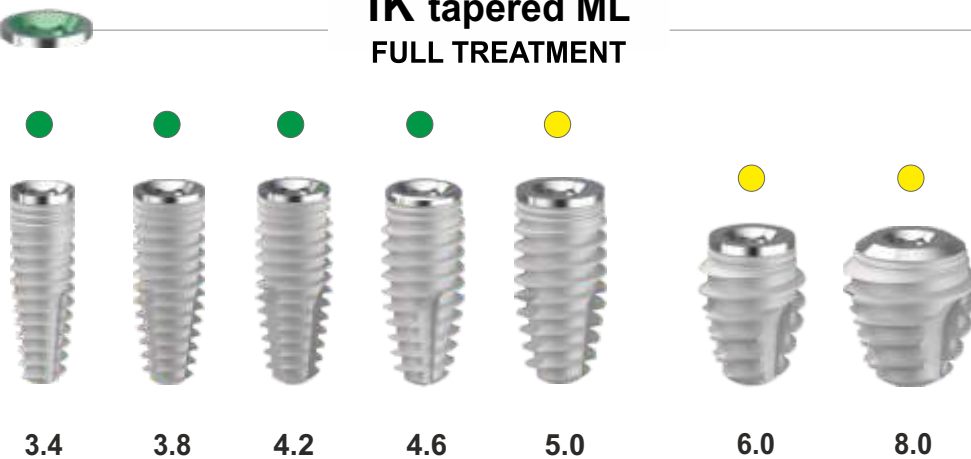

macro geometry

IA tapered ML
FULL TREATMENT

3.4 3.8 4.2 4.6 5.0

IK Narrow 4°
HALF TREATMENT

2.9

IC Narrow
FULL TREATMENT

3.0 3.4

IBK Oneseal 5°
FULL TREATMENT

3.4 3.8 4.2 4.6 5.0

IK OneTime
HALF TREATMENT

3.4 3.8 4.6

IM active BANP 5°
FULL TREATMENT

3.5 4.0 4.5 5.0

IC cylindrical BANP 5°
FULL TREATMENT

3.5 4.0 4.5 5.0

macro geometry

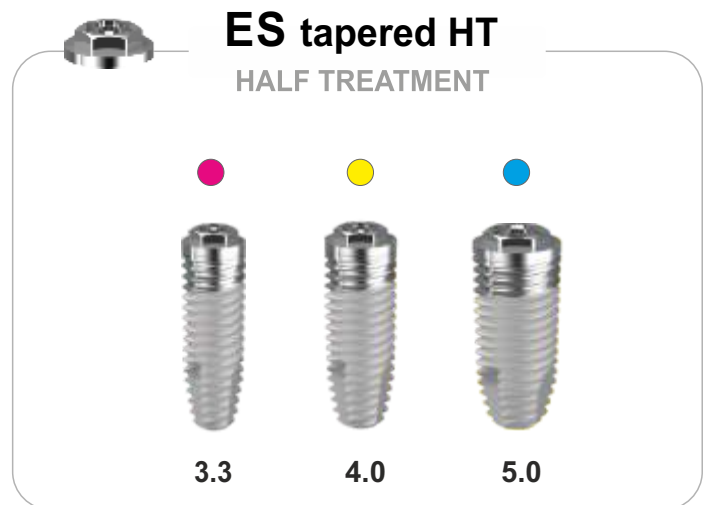
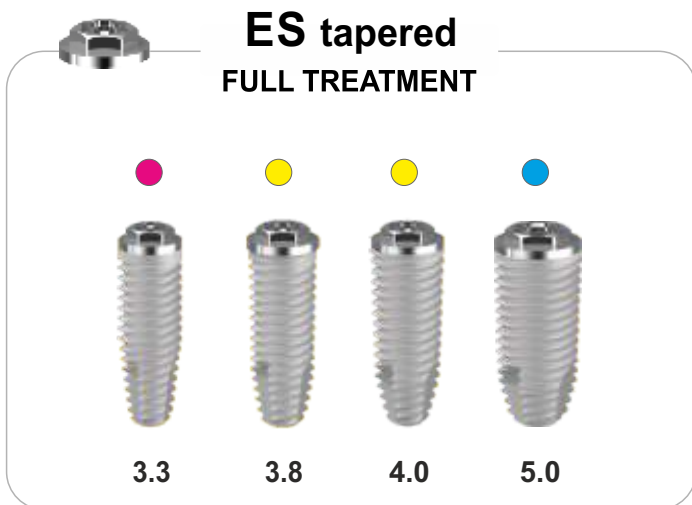
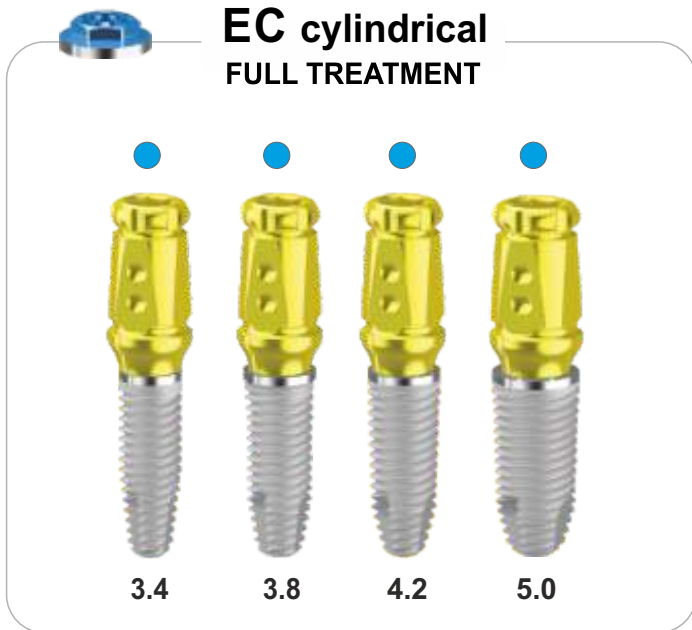

macro geometry

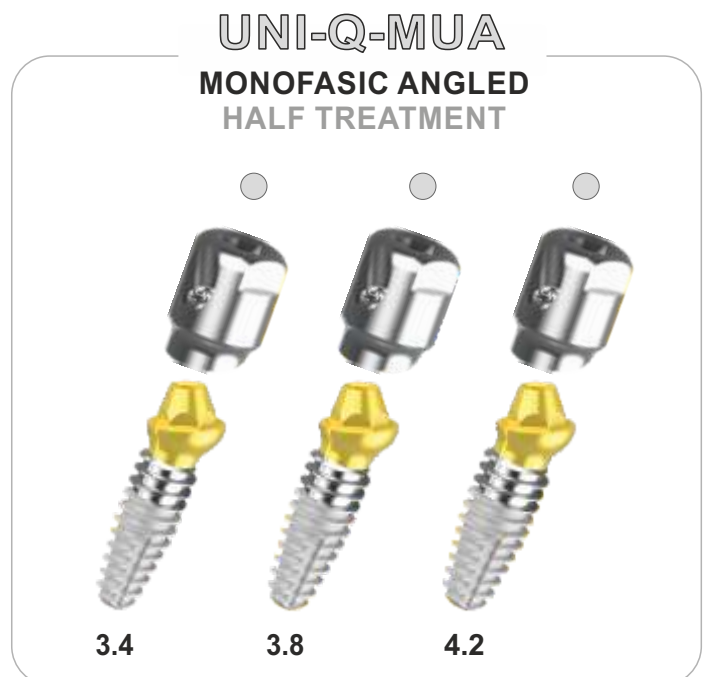
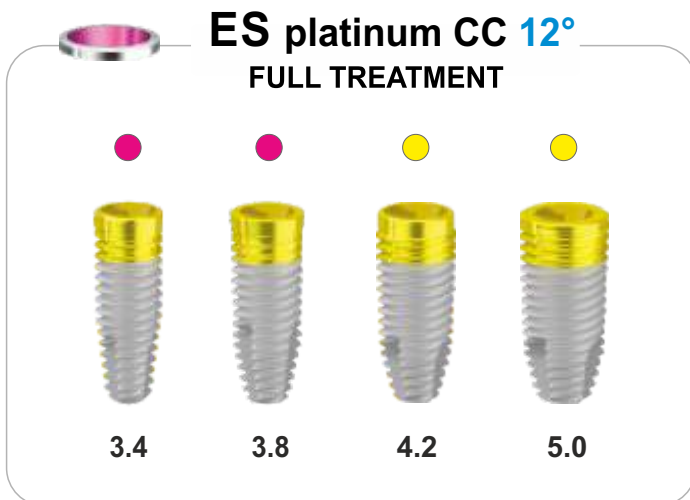
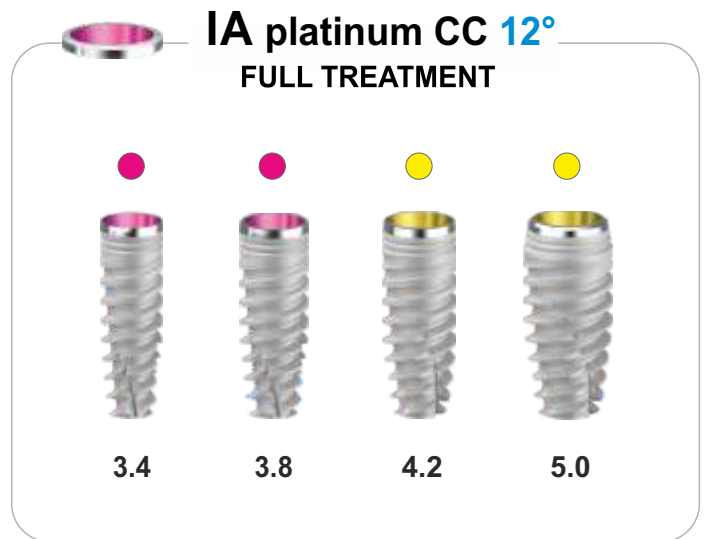

tooth - implant ratio

Resistenza Meccanica Implantare ed Indicazioni d'uso Implants Mechanical Resistance and Indications for Use

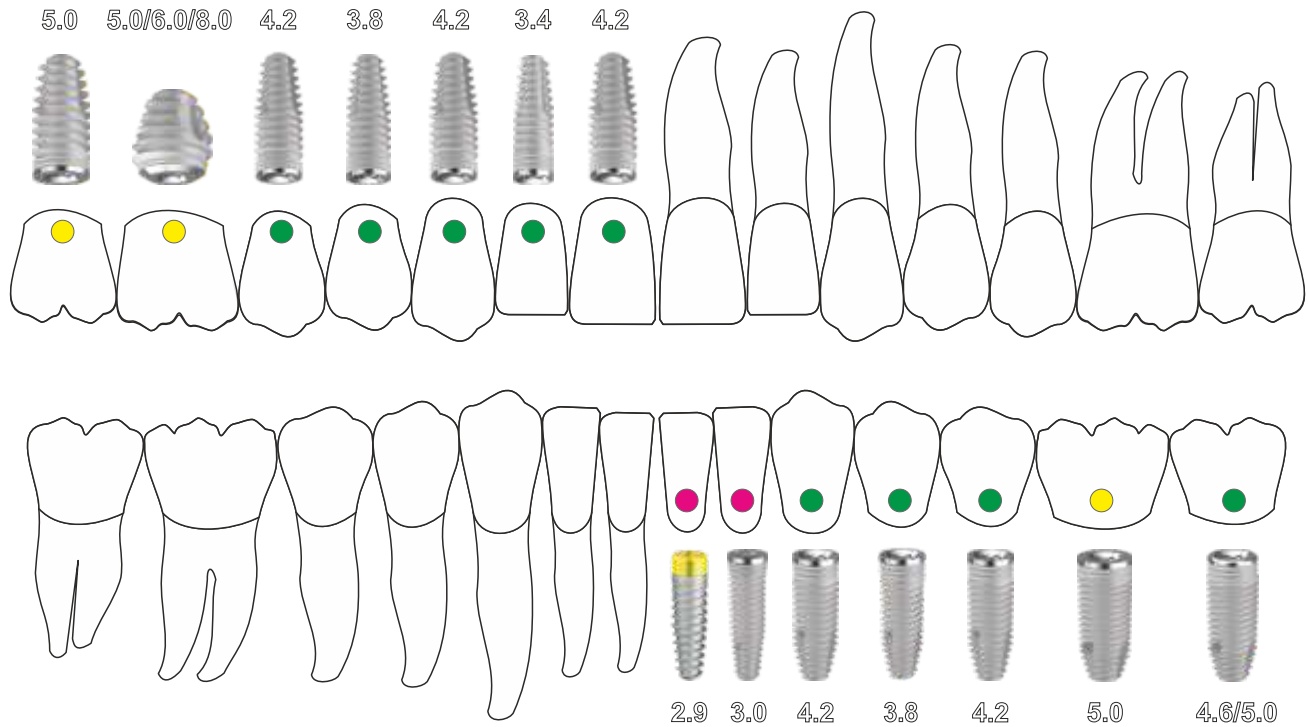

Esempi di Protesi Mista Denti/Impianti Bilanciata Examples of Balanced Teeth/Implants Prosthetics Mixed

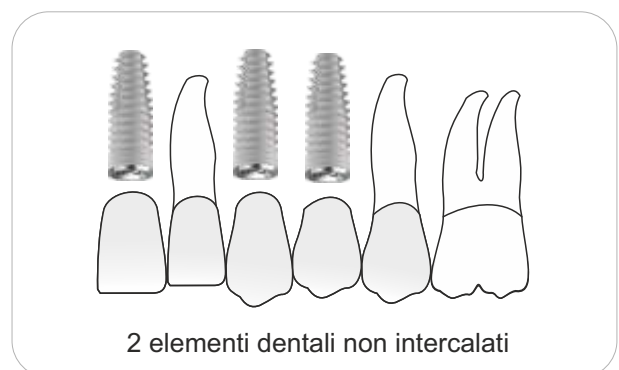
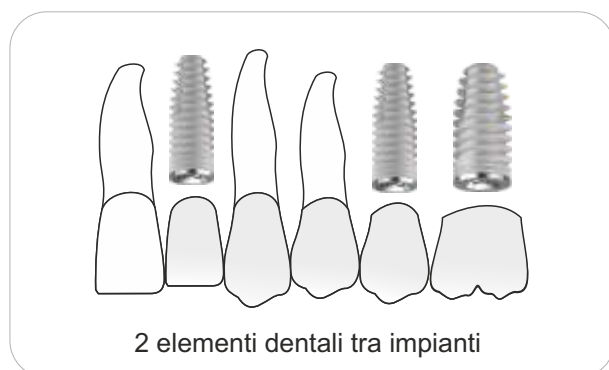
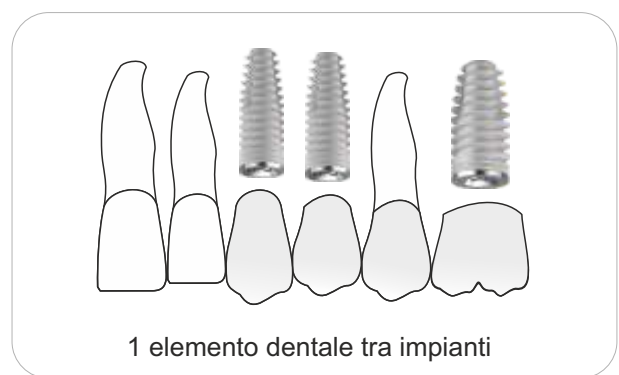
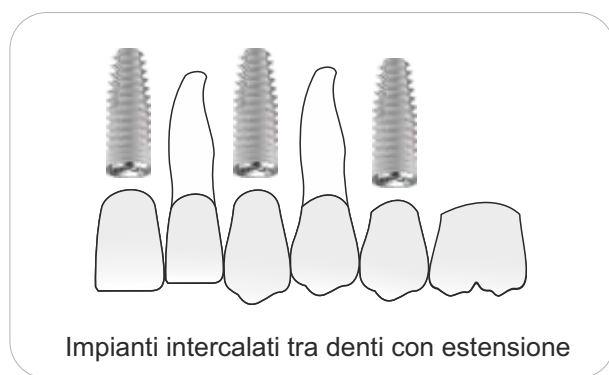

instruments & torque

Limiti sullo Scambio delle Forze tra Impianti e Strumenti Implants and Instruments Limits on Forces Exchanges

INTERNAL HEXAGON

Max 50 Ncm



Max 80 Ncm

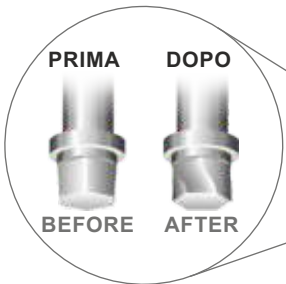

Max 100 Ncm

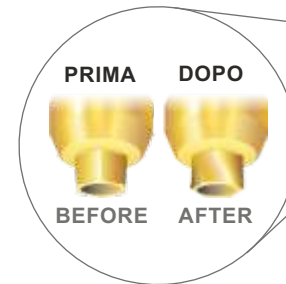

EXTERNAL HEXAGON

Max 50 Ncm

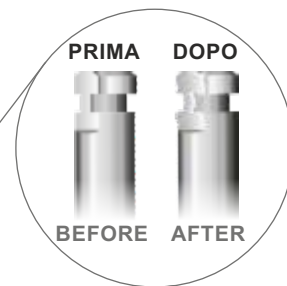

Max 80 Ncm

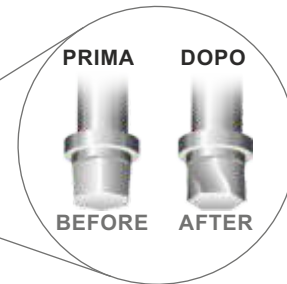

Max 60 Ncm

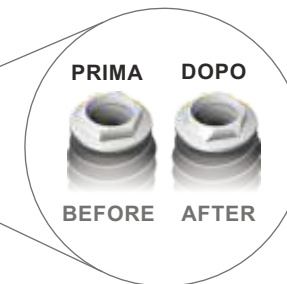

SCREW DRIVER HEXAGON

Max 40 Ncm

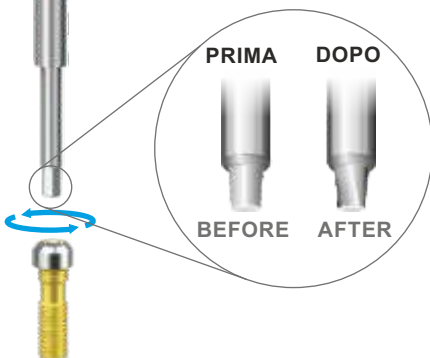

EPMV - Mini Vite Toronto **15 Ncm**



IPVIT - Viti Protesiche **32 Ncm**



IPVITG - Viti Protesiche **32 Ncm**



EPVITG - Viti Protesiche **32 Ncm**



EPVITB - Vite Protesica **32 Ncm**



micro geometry

Il trattamento di superficie Micro-Nano Ruvido DAE accelera i processi di guarigione ossea

1. Rimuove i residui organici di lavorazione in combinazione con la Decontaminazione al Plasma d'Argon
2. Arrotonda gli angoli vivi eliminando i micro-difetti
3. Incrementa la superficie e la bagnabilità (idrofilia superficiale), migliorando l'adesione dei primi ponti di fibrina
4. Aumenta l'adesione proteica
5. Massimizza l'adesione cellulare con rugosità Micro-Nano Metriche ideali per l'ancoraggio dei filamenti di actina (filopodi)
6. Cambia la chimica superficiale del Titanio che migliorando in biocompatibilità incrementa la proliferazione e la vitalità cellulare

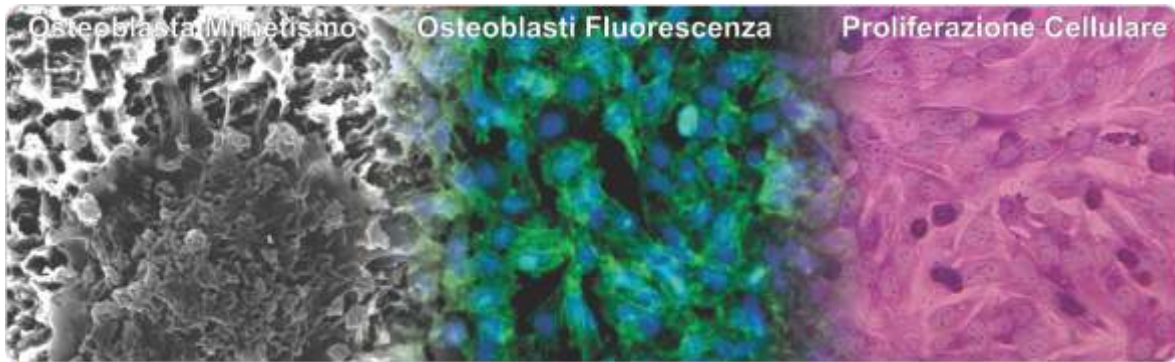

La topografia e la chimica di superficie interagiscono con i processi di differenziazione cellulare

La superficie implantare usa la microtopografia come linguaggio di comunicazione con le cellule del tessuto ospite. La pulizia in reattore al plasma freddo di Argon con confezionamento in ambiente controllato nell'assoluto rispetto delle procedure, gioca un ruolo fondamentale nel controllo delle endotossine adese (principale agente di risposta immunologica alle superfici implantari).

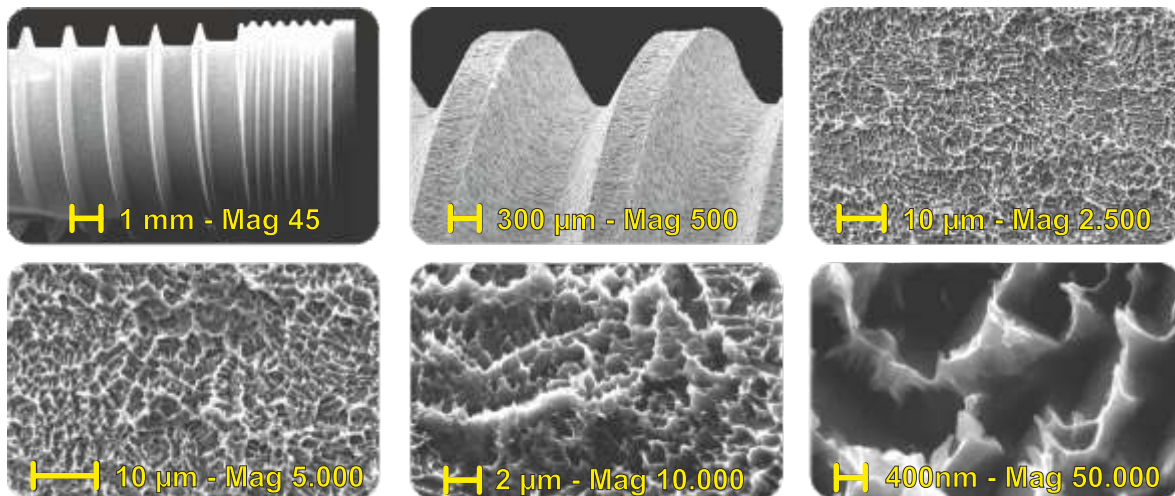

The Micro-Nano Rough DAE surface treatment speed up bone healing processes

1. Removes the manufacturing organic residuals along with Argon Plasma Cleaning
2. Smooths the edge and eliminates the micro-defects
3. Increases surface and wettability (hydrophilicity surface), improving the first fibrin bridges adhesion
4. Increases protein adhesion
5. Maximizes cellular adhesion through the Micro-Nano roughness suitable for actin filaments (phyllopods) anchoring
6. Changes the Titanium surface chemical characteristics improving the biocompatibility and increasing the cellular proliferation and vitality

Surface topography and chemistry interact with the cellular differentiation processes

The implant surface uses the microtopography as a communication language with the host tissue cells. The Plasma Argon Cold Cleaning with a controlled-environment packaging at a strict protocol procedures, play a key-role in the control of adhered endotoxins (main immunological response player to implant surfaces).

micro geometry - 4 treatments

DISTRIBUZIONE DEL TRATTAMENTO DI SUPERFICIE SULLA FORMA IMPLANTARE

Tutti gli impianti **Resista** presentano un trattamento di superficie localmente differenziato. La logica di distribuzione superficiale del trattamento è dettata dalla posizione endo-ossea dell'impianto che richiede caratteristiche differenti in funzione della presenza, più o meno ravvicinata della componente mucogengivale.

1. **Superficie Machined:** Spazzolata, rettificata e mascherata nel processo di irruvidimento
2. **Superficie Nanoruvida:** Trattamento veloce, nanoruvido con Ra medio inferiore al micron
3. **Superficie Microruvida 3/5 μ :** Trattamento DAE, microruvido con Ra medio tra 3/5 micron
4. **Superficie Microruvida 4/7 μ :** Trattamento DAE lento, microruvido con Ra medio tra 4/7 micron

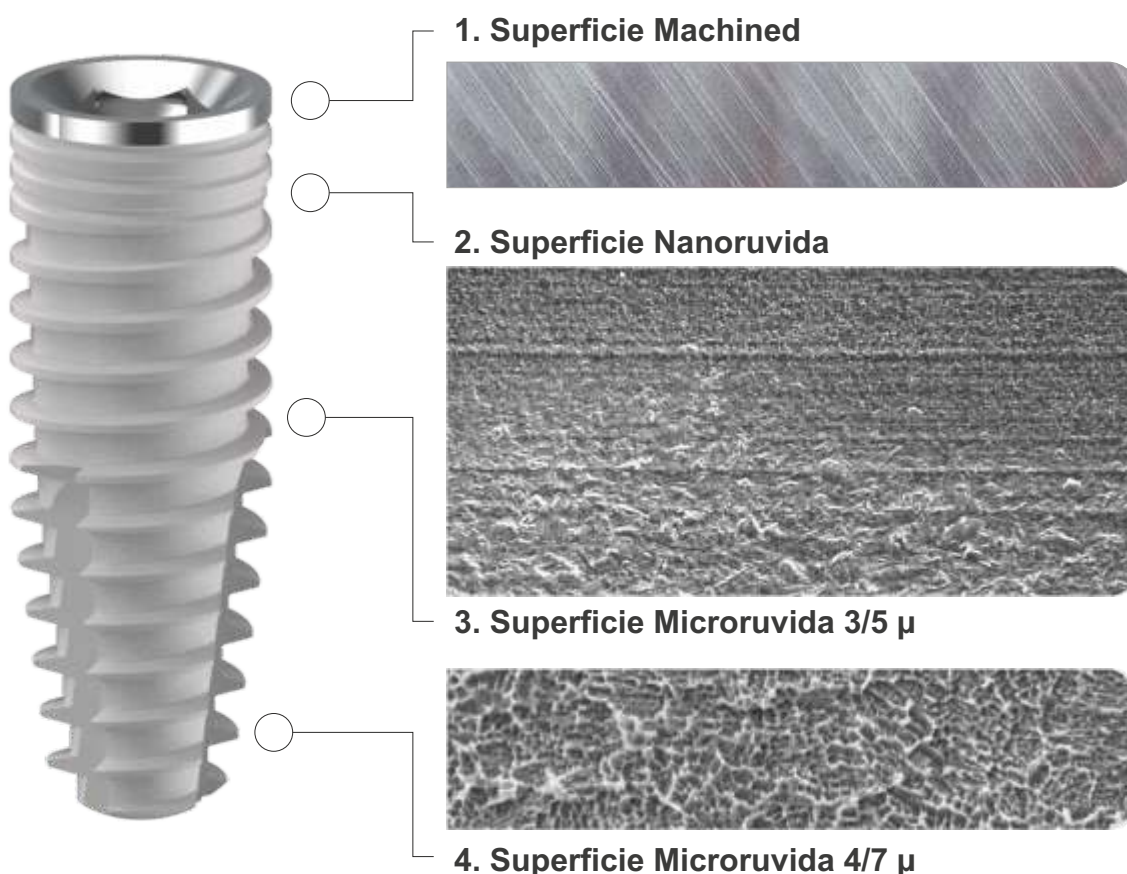

VEGF/VEGF-R/RUNX2 Upregulation in Human Periodontal Ligament Stem Cells Seeded on Dual Acid Etched Titanium Disk

Francesca Diomede, Guya Diletta Marconi, Marcos F. X. B. Cavalcanti, Jacopo Pizzicannella, Sante Donato Pierdomenico, Luigia Fonticoli, Adriano Piattelli and Oriana Trubiani

Materials 2020, 13, 706; doi:10.3390/ma13030706



SURFACE TREATMENT DISTRIBUTION ON IMPLANT'S BODY

All the **Resista**'s implants have a surface treatment that is locally differentiated. The logic of surface treatment distribution is dictated by the endo-osseous implant position which requires different characteristics dependin on the muco-gingival component presence around.

1. **Machined Surface:** Brushed, rectify and protected during the roughening process
2. **Nano-rough Surface:** Speedy treatment, nano-rough with average Ra less than one micron
3. **Micro-rough Surface: 3/5 μ :** DAE Treatment, micro-rough with average Ra between 3/5 μ
4. **Micro-rough Surface: 4/7 μ :** DAE Slow Treatment, micro-rough with average Ra between 4/7 μ

PUNTI DI FORZA DELLE LINEE IMPLANTARI RESISTA

- 1. Macro Geometrie:** Vasta gamma di forme implantari per le differenti necessità in campo chirurgico.
- 2. Micro Geometrie:** Trattamento di superficie differenziato di ultima generazione (DAE Micro e Nano rugoso), Anatasio TiO_2 antibatterico nella connessione e decontaminazione certificata in Reattore al Plasma Freddo di Argon con confezionamento in camera bianca.



The Bacterial Anti-Adhesive Activity of Double-Etched Titanium (DAE) as a Dental Implant Surface

Morena Petrini, Alessandra Giuliani, Emanuela Di Campi, Silvia Di Lodovico, Giovanna Iezzi, Adriano Piattelli and Simonetta D'Ercole¹
 International Journal of Molecular Sciences 2020, 21, 8315; doi:10.3390/ijms21218315

- 3. Mounter Multifunzione:** 4 componenti in un unico articolo (Mounter, Transfer, Abutment e Mounter per Chirurgia Computer Guidata) per massimizzare la resa ed ottimizzare i costi.
- 4. Componenti protesiche:** Vastissima gamma di varianti protesiche con tolleranze di lavorazione sulle connessioni esagonali di 7 micron, con profili emergenti curvilinei, connessioni piane e coniche, platform switching, viti in Titanio Dorate e rivestimenti in PVD TiN (più estetica e minore ritenzione di placca).
- 5. Strumentario Chirurgico:** Frese chirurgiche **3-Tech**, massima efficienza, minima invasività, basso coefficiente di attrito, tecnologia **PRO MSD** per applicazione osseo-densificante in senso antiorario, lunga durata, perfetta visibilità delle tacche laser e stop chirurgici millimetrati.



THE RESISTA'S IMPLANT LINE STRONG POINTS

- 1. Macro Geometry:** A vast range of implant shapes for different surgical needs.
- 2. Micro Geometry:** Last generation differentiated surface treated (DAE Micro and Nano rough), Certified Decontamination in Argon Cold Plasma Reactor with white clean room packaging.
- 3. Multifunctional Mounter:** 4 components in a single article (Mounter, Transfer, Abutment and Mounter for Computer Guided Surgery) to maximize result and minimize costs.
- 4. Prosthetic Parts:** A very wide range of prosthetic variants with 7 micron machining tolerances on the hexagon connection, with emerging curvilinear profiles, flat and conical connections, platform switching, golden titanium screws and PVD TiN coatings (more aesthetic and less retention of dental plaque).
- 5. Surgical Instruments:** Surgical Drills **3-Tech**, maximum efficiency, minimum trauma, smaller friction coefficient, **PRO MSD** technology for counterclockwise bone densifying application long, lasting resistance, perfect visibility of laser marking and surgical millimeters stop.

technology

COERENZA E LOGICA NEL RAPPORTO DIAMETRO FRESA/DIAMETRO NOCCIOLO-IMPIANTO

Le progettazioni della forma degli strumenti rotanti si basa sulla logica coerenza tra la dimensione degli impianti, nell'ingombro esterno, nel nocciolo interno e per la loro capacità di penetrazione.

Gli **impianti cilindrici** della linea **IC** presentano una porzione apicale affusolata per una lunghezza di 3mm. Gli **impianti conici** della linea **IK** presentano una porzione apicale affusolata per una lunghezza di 5mm.

Le frese si presentano rispettivamente con 2 / 3 sezioni apicali, adeguate per una preparazione del tunnel implantare rispetto alla geometria dell'impianto, mantenendo il miglior BIC di interfaccia osso / impianto.

Ogni gradino è fornito di un tagliente affilato per agevolare la penetrazione, minimizzando l'attrito ed il surriscaldamento

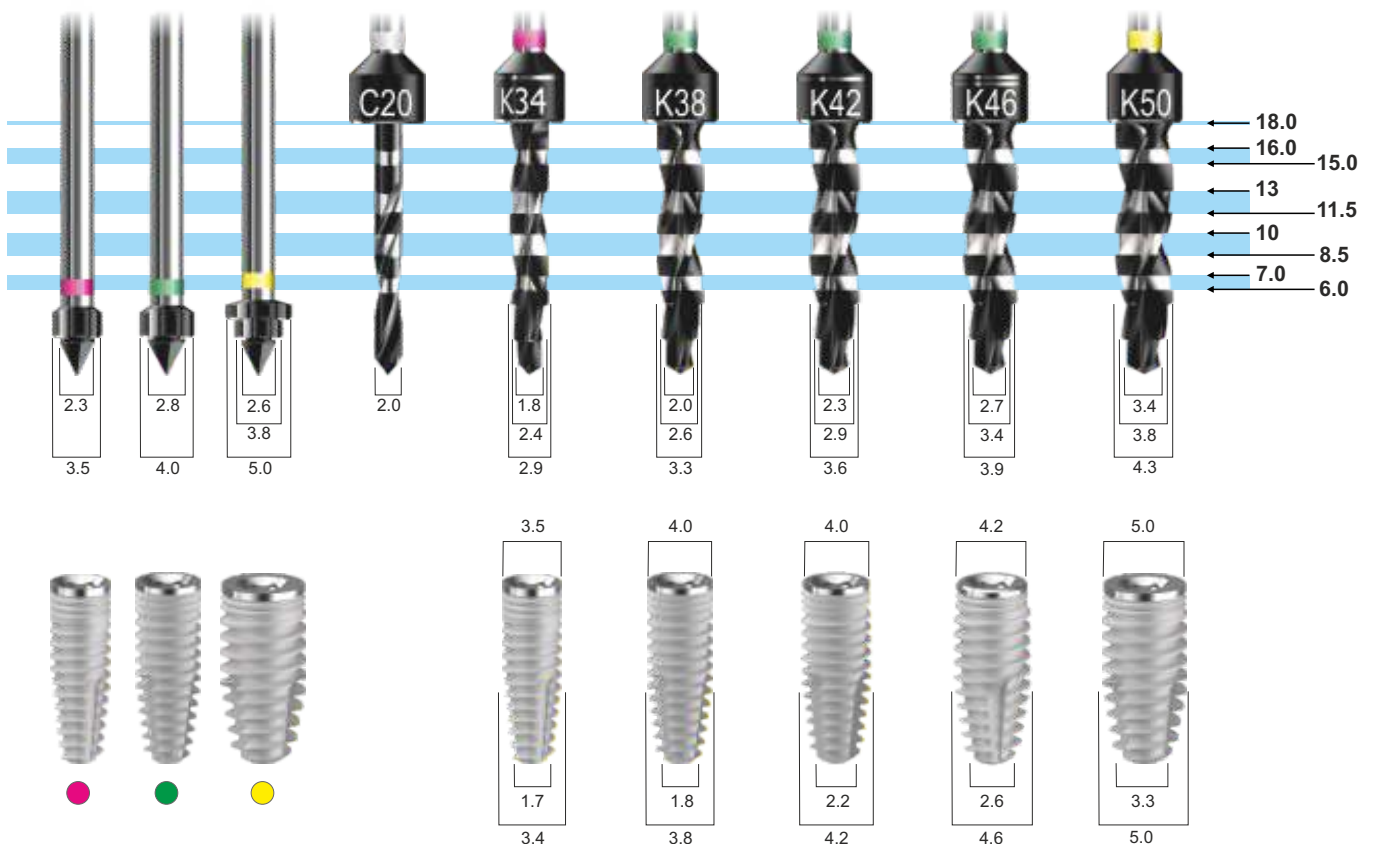

Various bio-mechanical factors affecting heat generation during osteotomy preparation: A systematic review

Chirag J Chauhan¹, Darshana N Shah¹, Foram B Sutaria¹

Indian J Dent Res. Jan-Feb 2018;29(1):81-92. doi: 10.4103/ijdr.IJDR_729_16.



LOGIC RELATION BETWEEN DRILL AND IMPLANT CORE

The rotary instruments design and shape is based on the logical coherence between the implants size, in the external dimensions, internal core and their penetration properties.

The **IC** line **Cylindrical Implants** have a tapered apical portion 3mm long.

The **IK** line **Conical Implants** have a tapered apical portion 5mm long.

The drills have respectively 2/3 apical sections, suitable for the implant tunnel preparation, with respect to the implant geometry, maintaining the best bone implant contact (BIC).

Each step drill is equipped with a sharp cutting edge to facilitate penetration, minimizing friction and overheating.

PRO MSD drilling technology

IL CONDIZIONAMENTO DEI PROTOCOLLI CHIRURGICI

Le geometrie implantari differenziate nella macro/micro forma, prevedono applicazioni diverse sia in funzione delle necessità chirurgico/protesiche (carico immediato, carico precoce o carico posticipato) sia in base alle condizioni della componente ossea/anatomica del paziente da riabilitare.

Tuttavia, si richiedono spesso indispensabili manovre chirurgiche e protocolli alternativi per migliorare le prestazioni implantari in funzione delle caratteristiche morfologiche delle strutture ossee residue.

La riuscita di tali manovre, come risultato di applicazioni combinate di strumenti e protocolli personalizzati, rappresenta la differente risposta al problema in relazione alle personali capacità operatorie ed alla presenza più o meno marcata di strumenti e mezzi adeguati all'applicazione delle stesse.

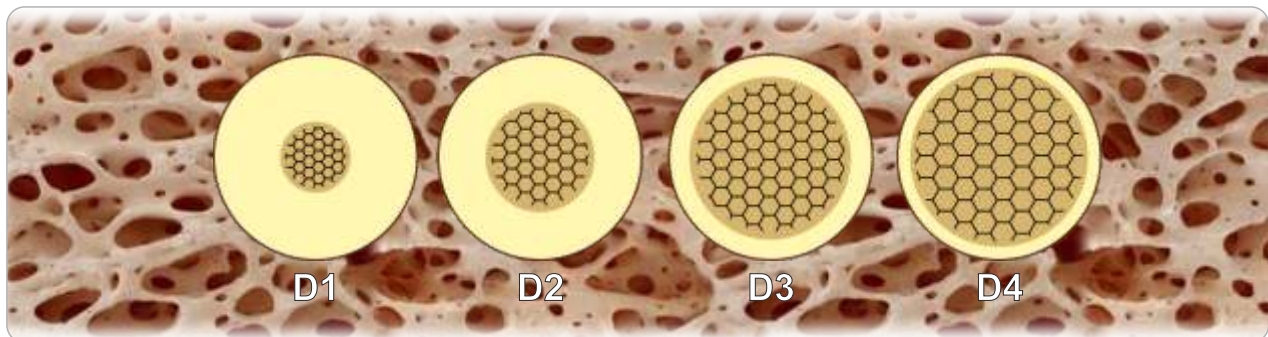

✓ Bone classification: clinical-histomorphometric comparison

Trisi P, Rao W. - Clin Oral Implants Res. 1999 Feb;10(1):1-7. doi: 10.1034/j.1600-0501.1999.100101.x.

OSSEODENSIFICAZIONE MECCANICA IN ROTAZIONE ANTIORARIA

L'osseodensificazione tramite strumenti rotanti è una recente tecnica chirurgica per la preparazione del sito implantare che può essere associata a differenti protocolli, applicabili in quelle particolari condizioni anatomiche dove la qualità ossea risulta scarsa e con dimensioni verticali / orizzontali insufficienti.

Questo approccio di osseo-condensazione osteotomica non sottrattiva, genera un aumento della densità ossea peri-osteotomica, con il risparmio del tessuto stesso e l'incremento della stabilità primaria implantare.



THE CONDITIONING OF SURGICAL PROTOCOLS

The differentiated implant geometries in the macro/micro shape provide for different applications, both according to the surgical/prosthetic requirements (immediate loading, early loading or postponed loading) and according to the conditions of the bone/anatomical component of the patient who needs rehabilitation. However, surgical maneuvers and alternative protocols are often required to improve implant performance, according to the morphological characteristics of the residual bone structures.

The success of these maneuvers, that is often the result of a customized tools and protocols combination, represents the different response to the problem in relation to the personal operating skills and the presence of tools suitable for their application.

MECHANICAL OSSEODENSIFICATION IN ANTI-CLOCKWISE ROTATION

The osseodensification using rotary instruments is a recent surgical technique for the implant site preparation that can be associated with different protocols; these protocols can be used in those particular anatomical conditions such as poor bone quality and insufficient vertical / horizontal dimensions.

This non-subtractive osteotomic bone-condensation approach produces an increase in peri-osteotomic bone density, saving the tissue and increasing the primary implant stability.

PRO MSD drilling technology

FRESE CHIRURGICHE RESISTA PRO MSD - Modular Surgical Drilling

Le Frese Chirurgiche Modulari a geometria variabile sono frese elicoidali a 3 sezioni con spoglia raggiata progressiva, utilizzabili in senso **orario** ed **antiorario**.

Il diametro di ogni fresa varia, con un rapporto costante, di 0,4mm (30/34/38/42/46/50), permettendo così all'operatore la scelta di utilizzo in funzione della qualità ossea (sovra-preparazione o sotto-preparazione).

Tutte le frese sono rivestite con un coating di lubrificante solido in diamante sintetico DLC (Diamond Like Carbon) che massimizza le prestazioni in termini di resistenza meccanica e riduzione dell'attrito.

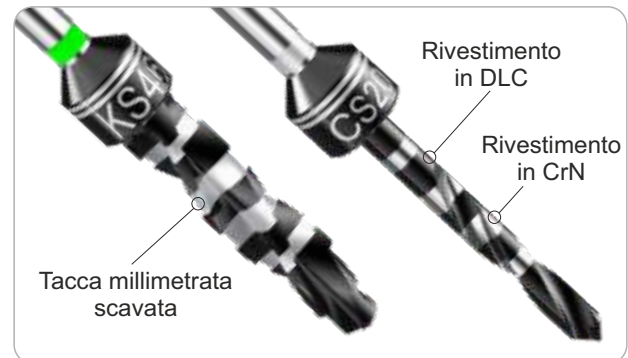
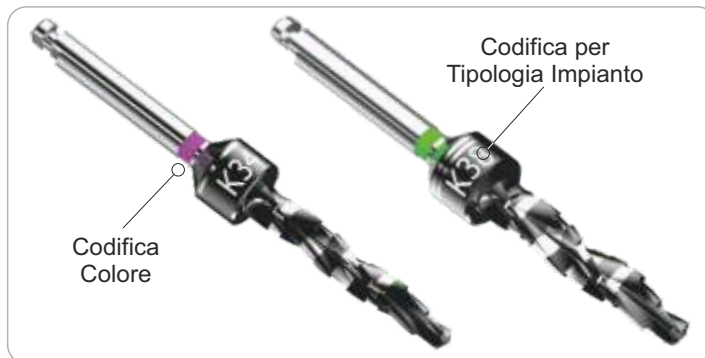

ROTAZIONE ANTIORARIA

La rotazione antioraria, invertendo le forze in gioco, genera 3 effetti differenti sulla pratica chirurgica di preparazione del tunnel implantare, che possono rivoluzionare la logica di fresatura conosciuta.

- 1) Spinta anteriore e laterale dell'osso asportato dalla punta più tutti i liquidi in gioco, sangue e fisiologica.
- 2) Espulsione ad "effetto martello" della fresa, con un miglioramento del controllo verticale.
- 3) Riduzione dell'efficienza di taglio a salvaguardia delle parti anatomiche sensibili.

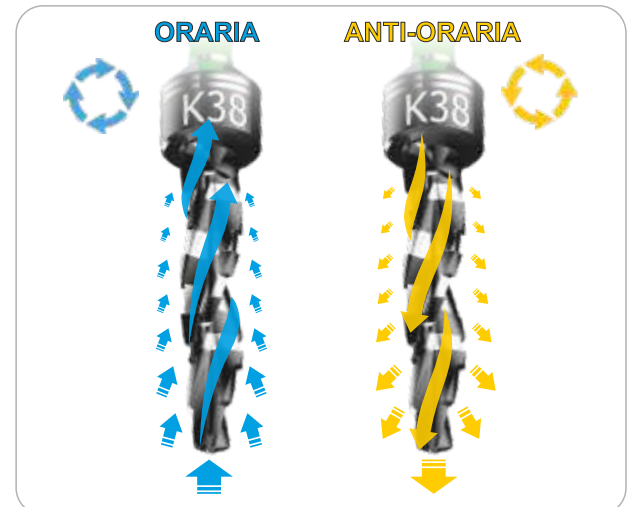

RESISTA PRO MSD SURGICAL DRILLS - Modular Surgical Drilling

The Modular Surgical Drills with variable geometry are 3-section helicoidal drills with progressive radius rake, that can be used clockwise and anticlockwise.

The diameter of each drill changes according to a constant ratio of 0.4mm (30/34/38/42/46/50): this allows the operator to choose the drill according to the bone quality (over-preparation or under-preparation). All the drills are coated with a DLC (Diamond Like Carbon) synthetic diamond solid lubricant that maximizes performance in terms of mechanical strength and friction reduction.

The **anticlockwise rotation**, reversing the involved forces, generates 3 different effects on the implant tunnel perforation, which can revolutionize the known milling logic.

- 1) Anterior and lateral thrust of the bone removed by the tip, and of the liquids as well, blood and physiological water.
- 2) Ejection and "hammer effect" of the drill that produce an improvement in vertical control.
- 3) Reduction of cutting efficiency to protect sensitive anatomical parts.



INTERNAL HEXAGON UNIVERSAL CONNECTION

TAPERED
SHAPE



IK

IK 34



TAPERED SHAPE Internal Hexagon

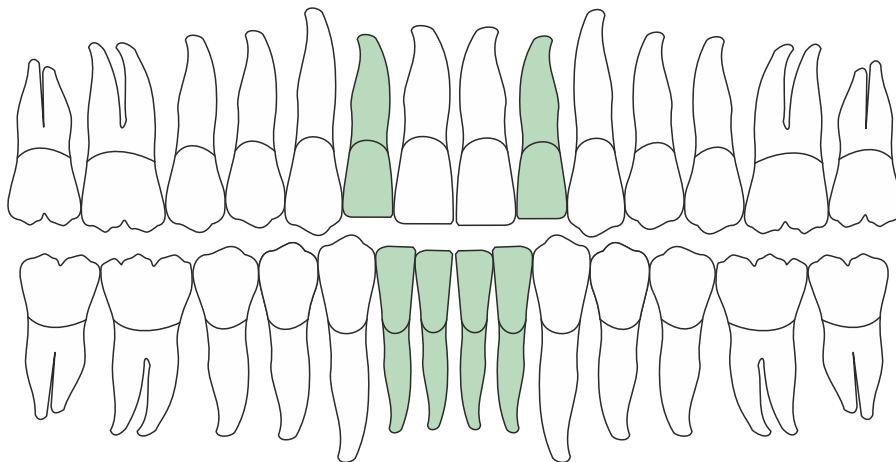
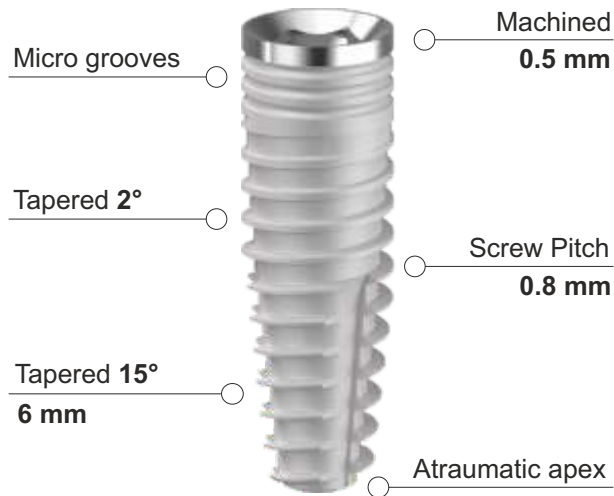

SOFT BONE - D4



STD BONE - D3/D2



HARD BONE - D1



Velocità di rotazione frese consigliata 500 - 800 rpm

Recommended milling burs rotation speed 500 - 800 rpm

3.4 Full Treatment - With Mounter



CODE	IMPLANT	LENGTH	PLATFORM	APEX
IK 3407	Ø 3.4	7.0 mm	Ø 3.5 CPS	Ø 1.8
IK 3408	Ø 3.4	8.5 mm	Ø 3.5 CPS	Ø 1.8
IK 3410	Ø 3.4	10 mm	Ø 3.5 CPS	Ø 1.8
IK 3411	Ø 3.4	11.5 mm	Ø 3.5 CPS	Ø 1.8
IK 3413	Ø 3.4	13 mm	Ø 3.5 CPS	Ø 1.8
IK 3415	Ø 3.4	15 mm	Ø 3.5 CPS	Ø 1.8

3.4 Half Treatment **Anatase TiO₂** - With Mounter



CODE	IMPLANT	LENGTH	PLATFORM	APEX
IK 3408 HT	Ø 3.4	8.5 mm	Ø 3.5 CPS	Ø 1.8
IK 3410 HT	Ø 3.4	10 mm	Ø 3.5 CPS	Ø 1.8
IK 3411 HT	Ø 3.4	11.5 mm	Ø 3.5 CPS	Ø 1.8
IK 3413 HT	Ø 3.4	13 mm	Ø 3.5 CPS	Ø 1.8
IK 3415 HT	Ø 3.4	15 mm	Ø 3.5 CPS	Ø 1.8

3.4 Full Treatment - Mounterless



CODE	IMPLANT	LENGTH	PLATFORM	APEX
IK 3407 ML	Ø 3.4	7.0 mm	Ø 3.5 CPS	Ø 1.8
IK 3408 ML	Ø 3.4	8.5 mm	Ø 3.5 CPS	Ø 1.8
IK 3410 ML	Ø 3.4	10 mm	Ø 3.5 CPS	Ø 1.8
IK 3411 ML	Ø 3.4	11.5 mm	Ø 3.5 CPS	Ø 1.8
IK 3413 ML	Ø 3.4	13 mm	Ø 3.5 CPS	Ø 1.8
IK 3415 ML	Ø 3.4	15 mm	Ø 3.5 CPS	Ø 1.8

IK 38



TAPERED SHAPE Internal Hexagon

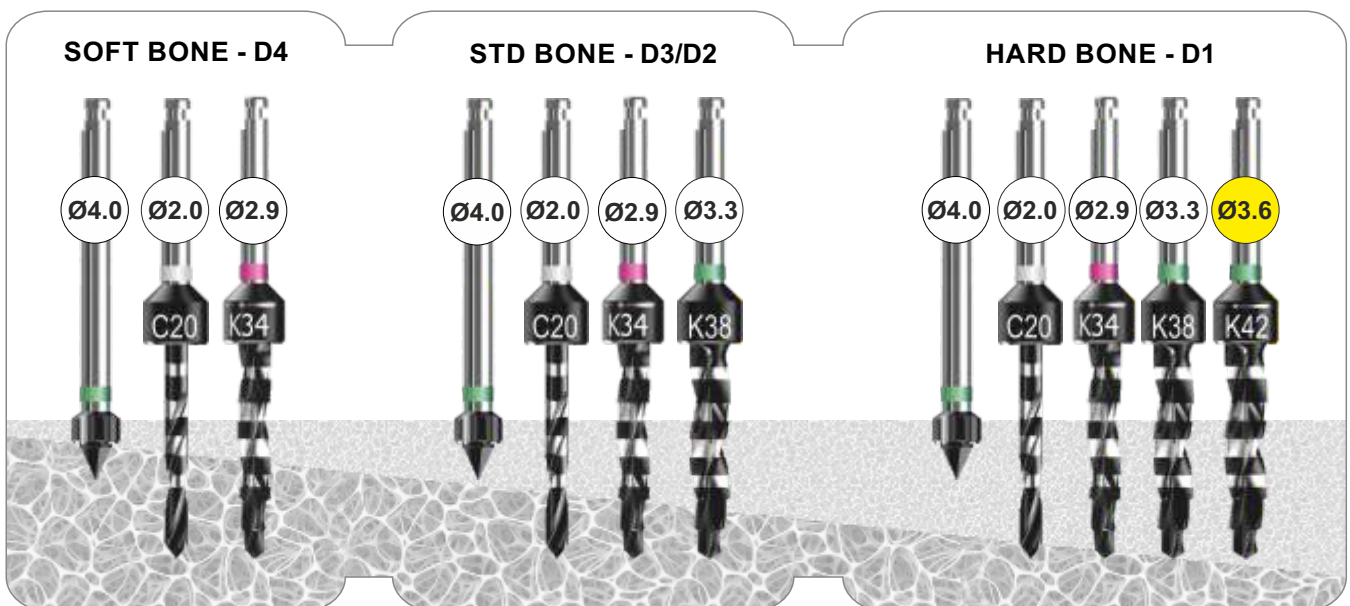
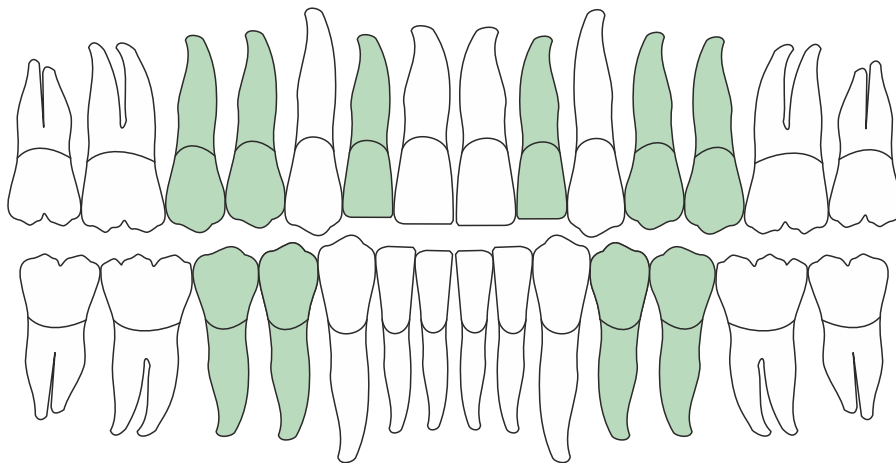
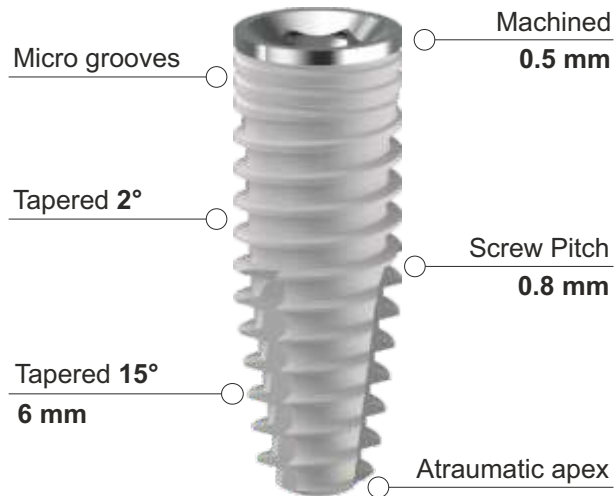

Velocità di rotazione frese consigliata 500 - 800 rpm

Recommended milling burs rotation speed 500 - 800 rpm

3.8 Full Treatment - With Mounter



CODE	IMPLANT	LENGTH	PLATFORM	APEX
IK 3808	Ø 3.8	8.5 mm	Ø 4.0	Ø 1.9
IK 3810	Ø 3.8	10 mm	Ø 4.0	Ø 1.9
IK 3811	Ø 3.8	11.5 mm	Ø 4.0	Ø 1.9
IK 3813	Ø 3.8	13 mm	Ø 4.0	Ø 1.9
IK 3815	Ø 3.8	15 mm	Ø 4.0	Ø 1.9
IK 3818	Ø 3.8	18 mm	Ø 4.0	Ø 1.9

3.8 Half Treatment **Anatase TiO₂** - With Mounter



CODE	IMPLANT	LENGTH	PLATFORM	APEX
IK 3808 HT	Ø 3.8	8.5 mm	Ø 4.0	Ø 1.9
IK 3810 HT	Ø 3.8	10 mm	Ø 4.0	Ø 1.9
IK 3811 HT	Ø 3.8	11.5 mm	Ø 4.0	Ø 1.9
IK 3813 HT	Ø 3.8	13 mm	Ø 4.0	Ø 1.9
IK 3815 HT	Ø 3.8	15 mm	Ø 4.0	Ø 1.9

3.8 Full Treatment - Mounterless



CODE	IMPLANT	LENGTH	PLATFORM	APEX
IK 3807 ML	Ø 3.8	7.0 mm	Ø 4.0	Ø 1.9
IK 3808 ML	Ø 3.8	8.5 mm	Ø 4.0	Ø 1.9
IK 3810 ML	Ø 3.8	10 mm	Ø 4.0	Ø 1.9
IK 3811 ML	Ø 3.8	11.5 mm	Ø 4.0	Ø 1.9
IK 3813 ML	Ø 3.8	13 mm	Ø 4.0	Ø 1.9
IK 3815 ML	Ø 3.8	15 mm	Ø 4.0	Ø 1.9

IK 42



TAPERED SHAPE Internal Hexagon

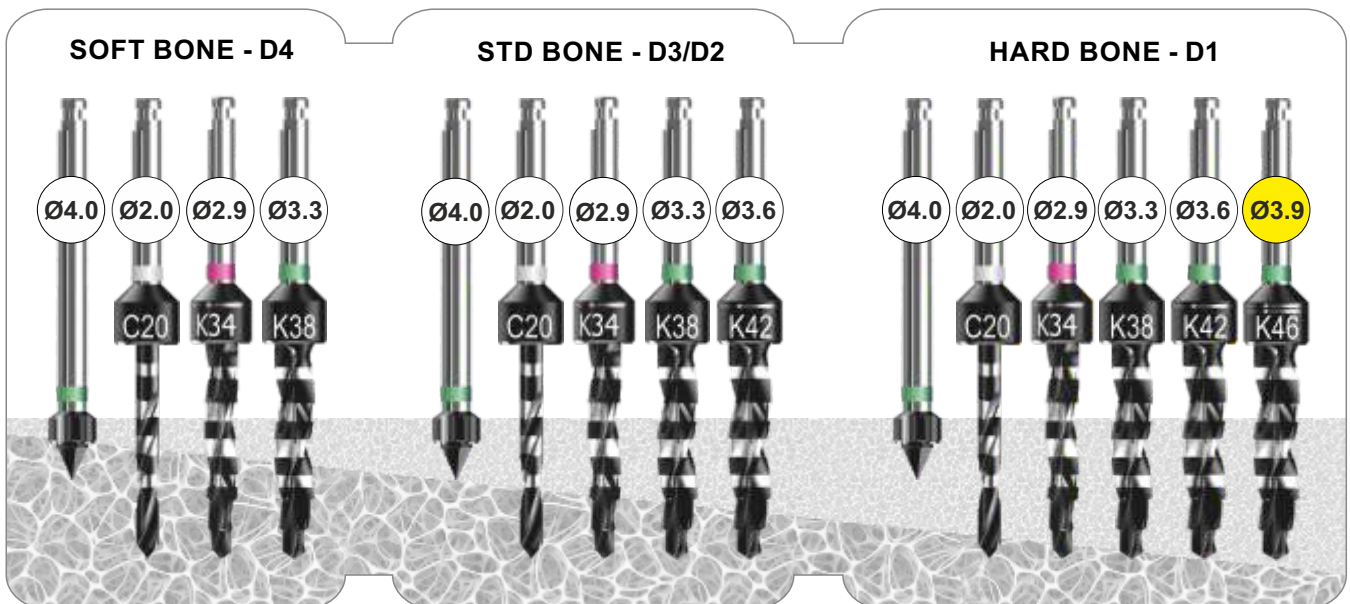
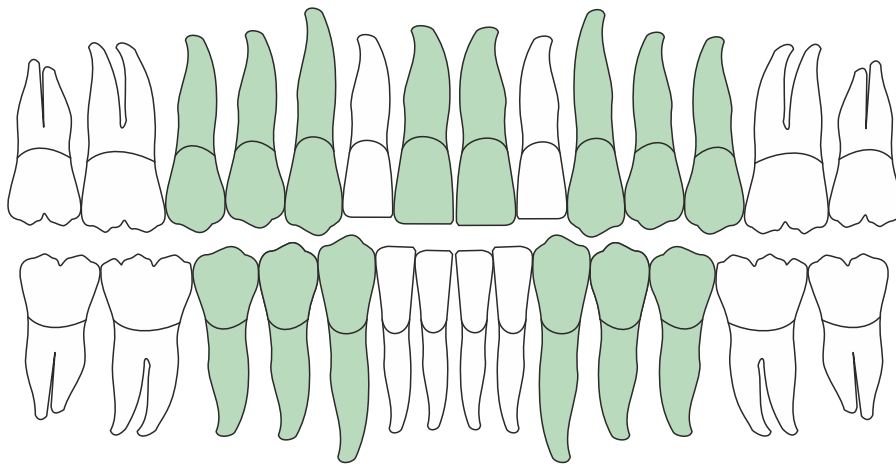
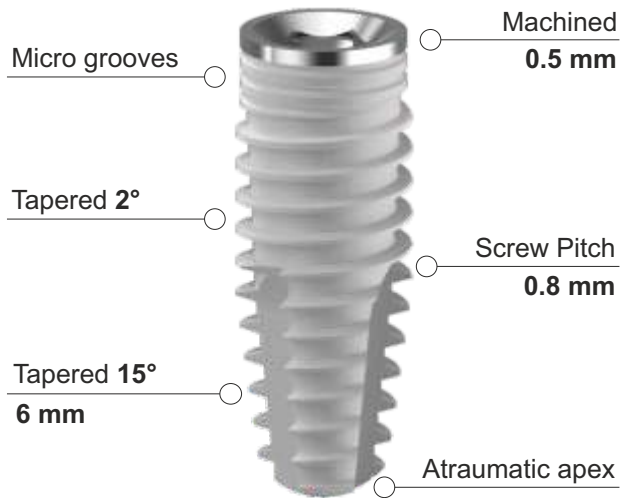

Velocità di rotazione frese consigliata 500 - 800 rpm

Recommended milling burs rotation speed 500 - 800 rpm

4.2 Full Treatment - With Mounter



CODE	IMPLANT	LENGTH	PLATFORM	APEX
IK 4207	Ø 4.2	7.0 mm	Ø 4.0	Ø 2.3
IK 4208	Ø 4.2	8.5 mm	Ø 4.0	Ø 2.3
IK 4210	Ø 4.2	10 mm	Ø 4.0	Ø 2.3
IK 4211	Ø 4.2	11.5 mm	Ø 4.0	Ø 2.3
IK 4213	Ø 4.2	13 mm	Ø 4.0	Ø 2.3
IK 4215	Ø 4.2	15 mm	Ø 4.0	Ø 2.3

4.2 Half Treatment **Anatase TiO₂** - With Mounter



CODE	IMPLANT	LENGTH	PLATFORM	APEX
IK 4208 HT	Ø 4.2	8.5 mm	Ø 4.0	Ø 2.3
IK 4210 HT	Ø 4.2	10 mm	Ø 4.0	Ø 2.3
IK 4211 HT	Ø 4.2	11.5 mm	Ø 4.0	Ø 2.3
IK 4213 HT	Ø 4.2	13 mm	Ø 4.0	Ø 2.3
IK 4215 HT	Ø 4.2	15 mm	Ø 4.0	Ø 2.3

4.2 Full Treatment - Mounterless



CODE	IMPLANT	LENGTH	PLATFORM	APEX
IK 4207 ML	Ø 4.2	7.0 mm	Ø 4.0	Ø 2.3
IK 4208 ML	Ø 4.2	8.5 mm	Ø 4.0	Ø 2.3
IK 4210 ML	Ø 4.2	10 mm	Ø 4.0	Ø 2.3
IK 4211 ML	Ø 4.2	11.5 mm	Ø 4.0	Ø 2.3
IK 4213 ML	Ø 4.2	13 mm	Ø 4.0	Ø 2.3
IK 4215 ML	Ø 4.2	15 mm	Ø 4.0	Ø 2.3
IK 4218	Ø 4.2	18 mm	Ø 4.0	Ø 2.3
IK 4220	Ø 4.2	20 mm	Ø 4.0	Ø 2.3
IK 4222	Ø 4.2	22 mm	Ø 4.0	Ø 2.3
IK 4225	Ø 4.2	25 mm	Ø 4.0	Ø 2.3

IK 46



TAPERED SHAPE Internal Hexagon

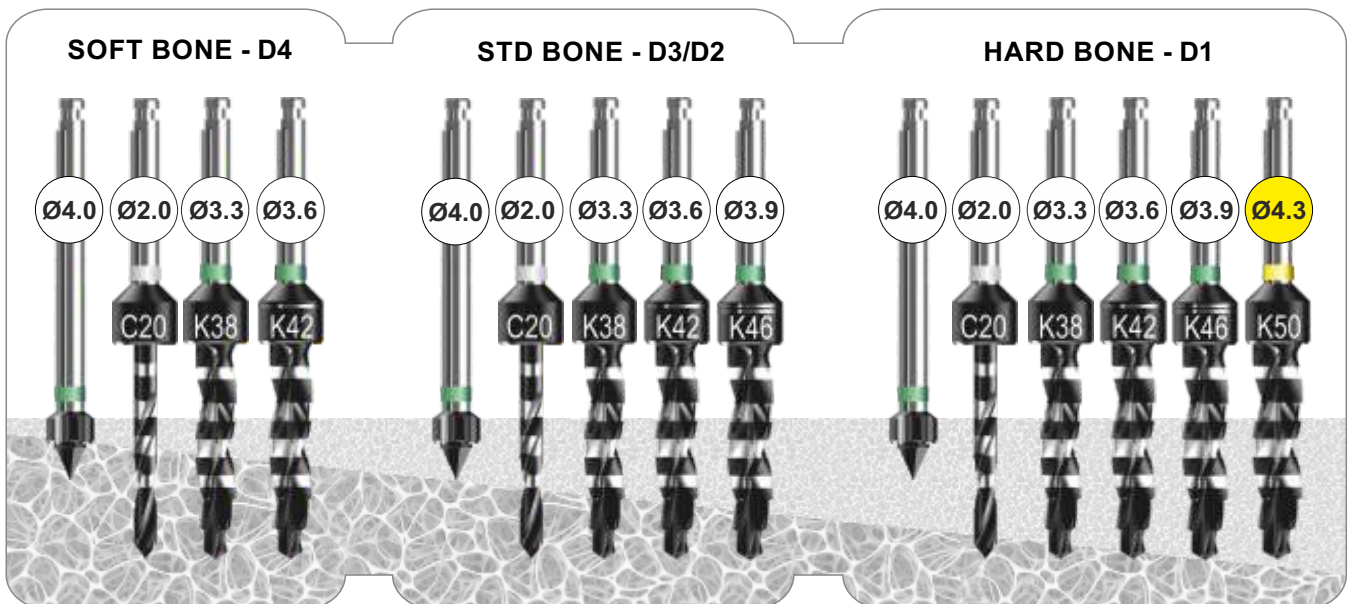
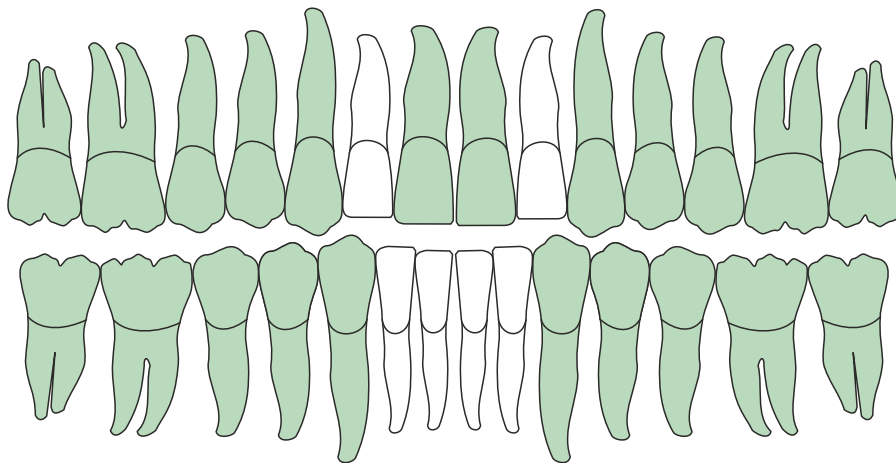
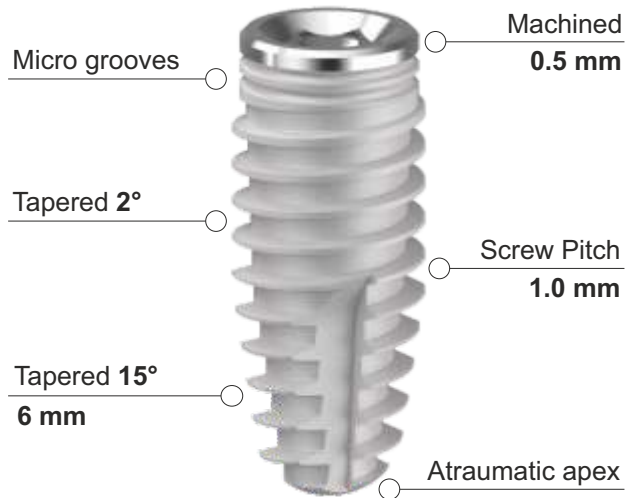

Velocità di rotazione frese consigliata 500 - 800 rpm

Recommended milling burs rotation speed 500 - 800 rpm

4.6 Full Treatment - With Mounter



CODE	IMPLANT	LENGTH	PLATFORM	APEX
IK 4607	Ø 4.6	7.0 mm	Ø 4.2	Ø 2.5
IK 4608	Ø 4.6	8.5 mm	Ø 4.2	Ø 2.5
IK 4610	Ø 4.6	10 mm	Ø 4.2	Ø 2.5
IK 4611	Ø 4.6	11.5 mm	Ø 4.2	Ø 2.5
IK 4613	Ø 4.6	13 mm	Ø 4.2	Ø 2.5
IK 4615	Ø 4.6	15 mm	Ø 4.2	Ø 2.5

4.6 Half Treatment **Anatase TiO₂** - With Mounter



CODE	IMPLANT	LENGTH	PLATFORM	APEX
IK 4608 HT	Ø 4.6	8.5 mm	Ø 4.2	Ø 2.5
IK 4610 HT	Ø 4.6	10 mm	Ø 4.2	Ø 2.5
IK 4611 HT	Ø 4.6	11.5 mm	Ø 4.2	Ø 2.5
IK 4613 HT	Ø 4.6	13 mm	Ø 4.2	Ø 2.5
IK 4615 HT	Ø 4.6	15 mm	Ø 4.2	Ø 2.5

4.6 Full Treatment - Mounterless



CODE	IMPLANT	LENGTH	PLATFORM	APEX
IK 4607 ML	Ø 4.6	7.0 mm	Ø 4.2	Ø 2.5
IK 4608 ML	Ø 4.6	8.5 mm	Ø 4.2	Ø 2.5
IK 4610 ML	Ø 4.6	10 mm	Ø 4.2	Ø 2.5
IK 4611 ML	Ø 4.6	11.5 mm	Ø 4.2	Ø 2.5
IK 4613 ML	Ø 4.6	13 mm	Ø 4.2	Ø 2.5
IK 4615 ML	Ø 4.6	15 mm	Ø 4.2	Ø 2.5



INTERNAL HEXAGON

WIDE PLATFORM

DOUBLE CONNECTION

LARGE TAPERED
SHAPE



IK

IK 50

TAPERED SHAPE
Internal Hexagon

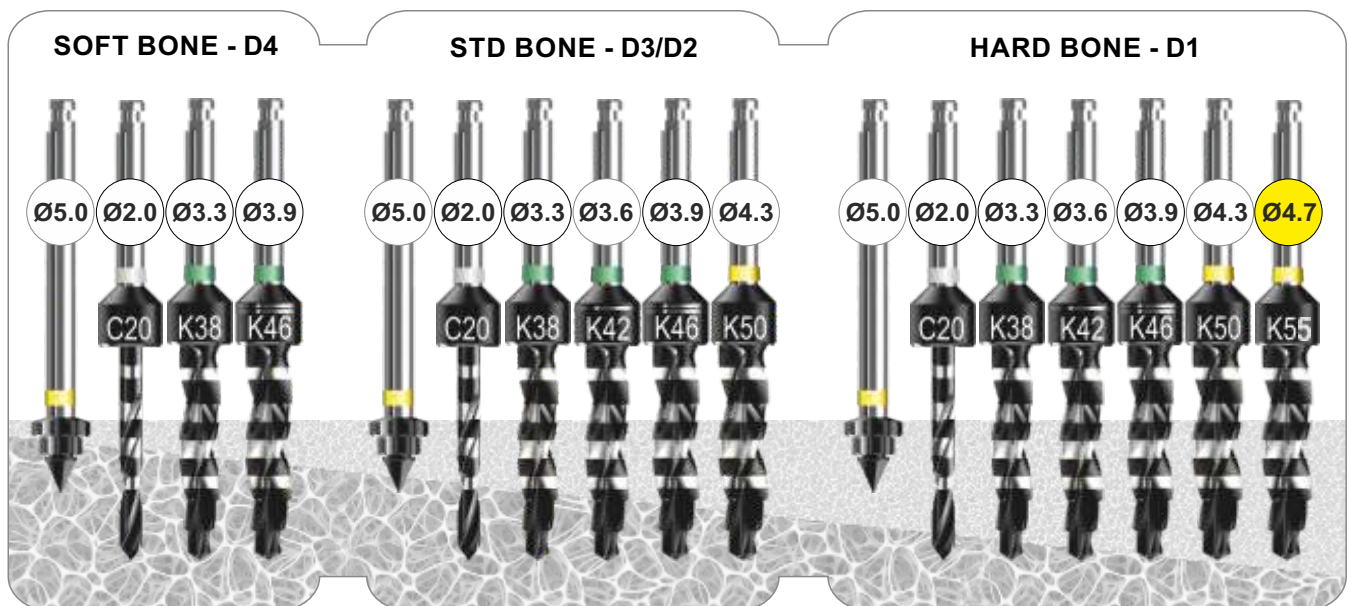
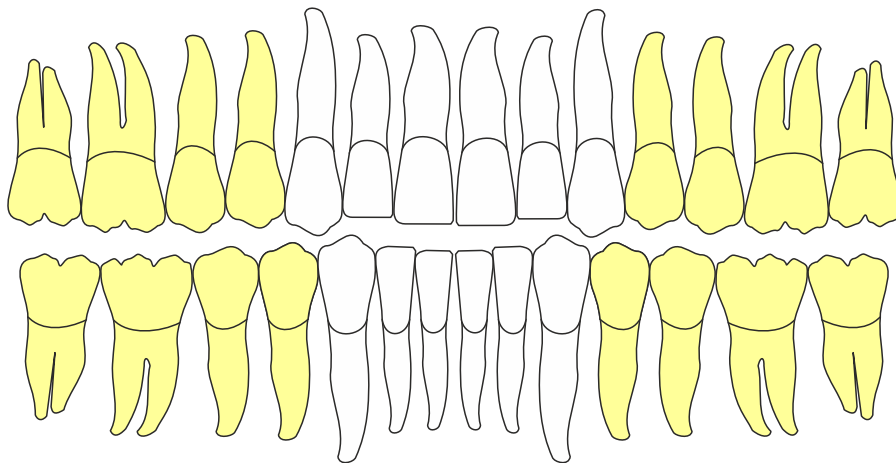
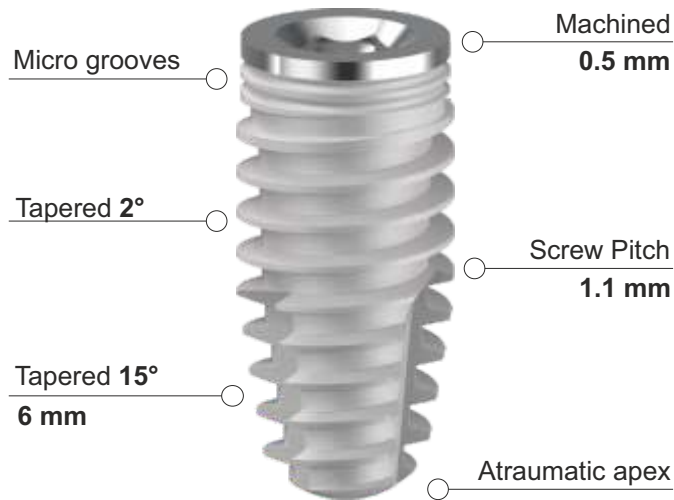

Velocità di rotazione frese consigliata 500 - 800 rpm

Recommended milling burs rotation speed 500 - 800 rpm

5.0 Full Treatment - With Mounter



CODE	IMPLANT	LENGTH	PLATFORM	APEX
IK 5007	Ø 5.0	7.0 mm	Ø 5.0	Ø 2.7
IK 5008	Ø 5.0	8.5 mm	Ø 5.0	Ø 2.7
IK 5010	Ø 5.0	10 mm	Ø 5.0	Ø 2.7
IK 5011	Ø 5.0	11.5 mm	Ø 5.0	Ø 2.7
IK 5013	Ø 5.0	13 mm	Ø 5.0	Ø 2.7

5.0 Half Treatment **Anatase TiO₂** - With Mounter



CODE	IMPLANT	LENGTH	PLATFORM	APEX
IK 5008 HT	Ø 5.0	8.5 mm	Ø 5.0	Ø 2.7
IK 5010 HT	Ø 5.0	10 mm	Ø 5.0	Ø 2.7
IK 5011 HT	Ø 5.0	11.5 mm	Ø 5.0	Ø 2.7
IK 5013 HT	Ø 5.0	13 mm	Ø 5.0	Ø 2.7

5.0 Full Treatment - Mounterless



CODE	IMPLANT	LENGTH	PLATFORM	APEX
IK 5007 ML	Ø 5.0	7.0 mm	Ø 5.0	Ø 2.7
IK 5008 ML	Ø 5.0	8.5 mm	Ø 5.0	Ø 2.7
IK 5010 ML	Ø 5.0	10 mm	Ø 5.0	Ø 2.7
IK 5011 ML	Ø 5.0	11.5 mm	Ø 5.0	Ø 2.7
IK 5013 ML	Ø 5.0	13 mm	Ø 5.0	Ø 2.7

IK 60 - IK 80

X-LARGE TAPERED SHAPE
Internal Hexagon

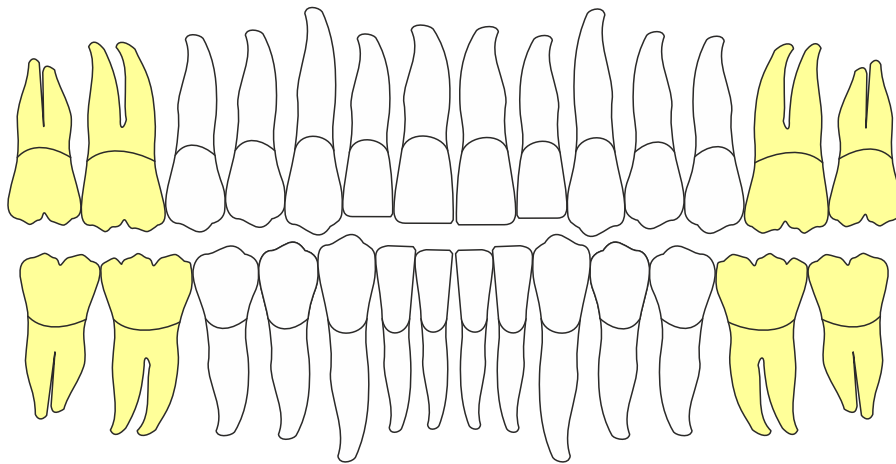

ONLY FOR SOFT AND STD BONE - D3/D4

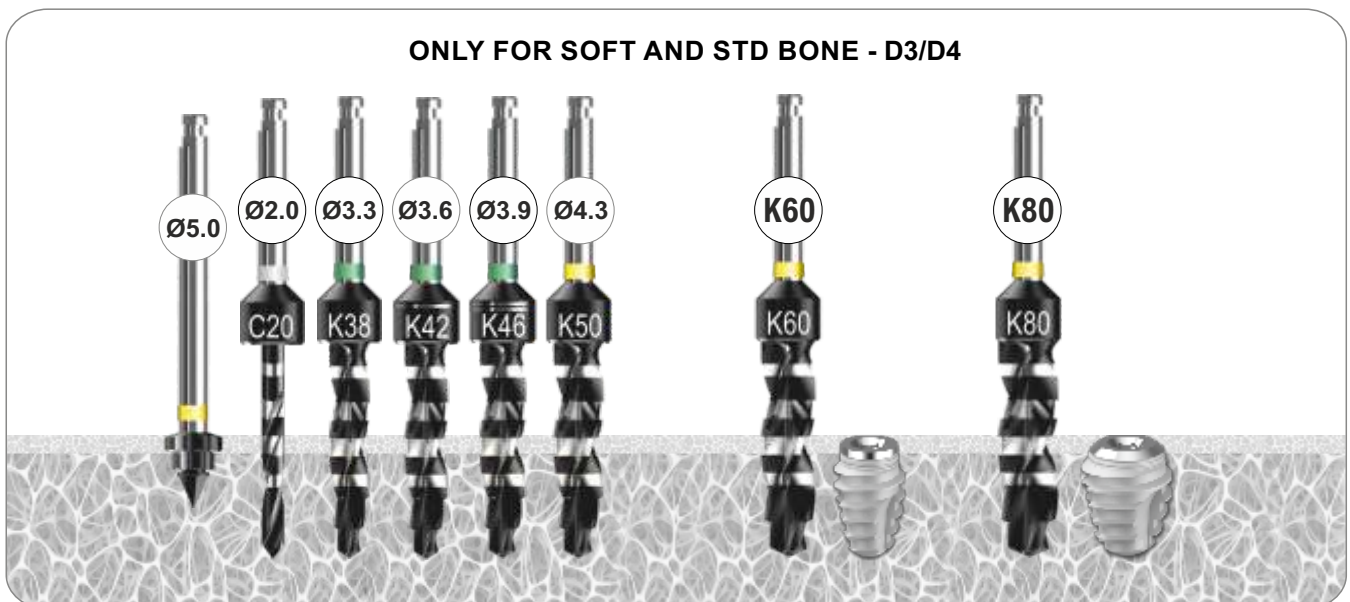

Velocità di rotazione frese consigliata 500 - 800 rpm

Recommended milling burs rotation speed 500 - 800 rpm

6.0 Full Treatment - Mounterless



CODE	IMPLANT	LENGTH	PLATFORM	APEX
IK 6007	Ø 6.0	7.0 mm	Ø 5.0	Ø 3.0
IK 6008	Ø 6.0	8.5 mm	Ø 5.0	Ø 3.0
IK 6010	Ø 6.0	10 mm	Ø 5.0	Ø 3.0

8.0 Full Treatment - Mounterless



CODE	IMPLANT	LENGTH	PLATFORM	APEX
IK 8007	Ø 8.0	7.0 mm	Ø 5.0	Ø 4.0
IK 8008	Ø 8.0	8.5 mm	Ø 5.0	Ø 4.0
IK 8010	Ø 8.0	10 mm	Ø 5.0	Ø 4.0





INTERNAL HEXAGON UNIVERSAL CONNECTION

ACTIVE BLADE
SHAPE



IA

IA 34



ACTIVE BLADE SHAPE Internal Hexagon

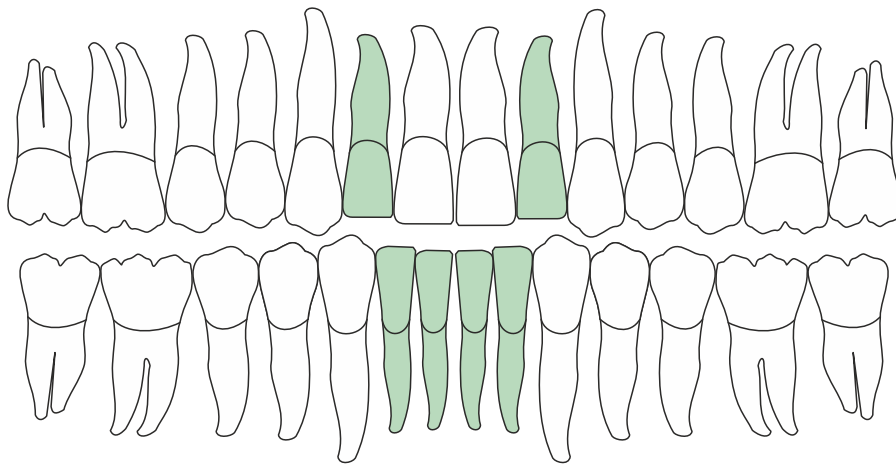
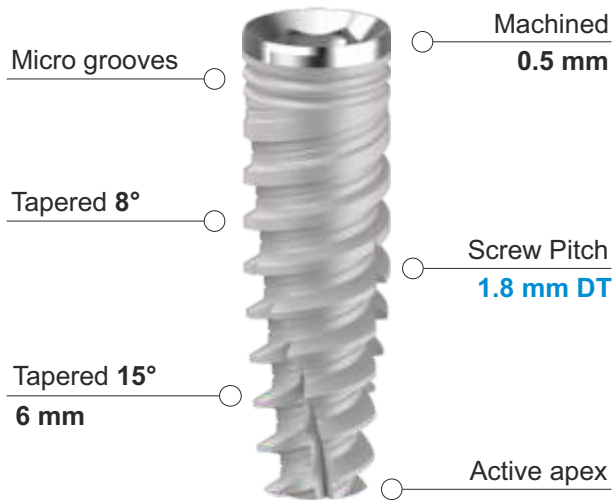

SOFT BONE - D4



STD BONE - D3/D2



HARD BONE - D1



Velocità di rotazione frese consigliata 500 - 800 rpm

Recommended milling burs rotation speed 500 - 800 rpm

3.4 Full Treatment - With Mounter



CODE	IMPLANT	LENGTH	PLATFORM	APEX
IA 3408	Ø 3.4	8.5 mm	Ø 3.5 CPS	Ø 2.2
IA 3410	Ø 3.4	10 mm	Ø 3.5 CPS	Ø 2.2
IA 3411	Ø 3.4	11.5 mm	Ø 3.5 CPS	Ø 2.2
IA 3413	Ø 3.4	13 mm	Ø 3.5 CPS	Ø 2.2

3.4 Full Treatment - Mounterless



CODE	IMPLANT	LENGTH	PLATFORM	APEX
IA 3408 ML	Ø 3.4	8.5 mm	Ø 3.5 CPS	Ø 2.2
IA 3410 ML	Ø 3.4	10 mm	Ø 3.5 CPS	Ø 2.2
IA 3411 ML	Ø 3.4	11.5 mm	Ø 3.5 CPS	Ø 2.2
IA 3413 ML	Ø 3.4	13 mm	Ø 3.5 CPS	Ø 2.2

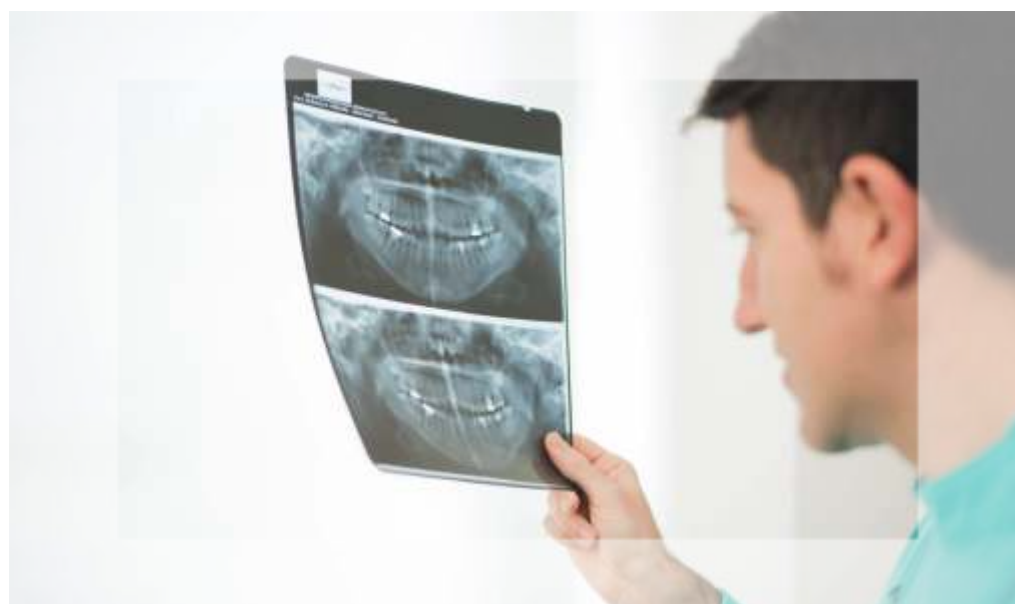

IA 38



ACTIVE BLADE SHAPE Internal Hexagon

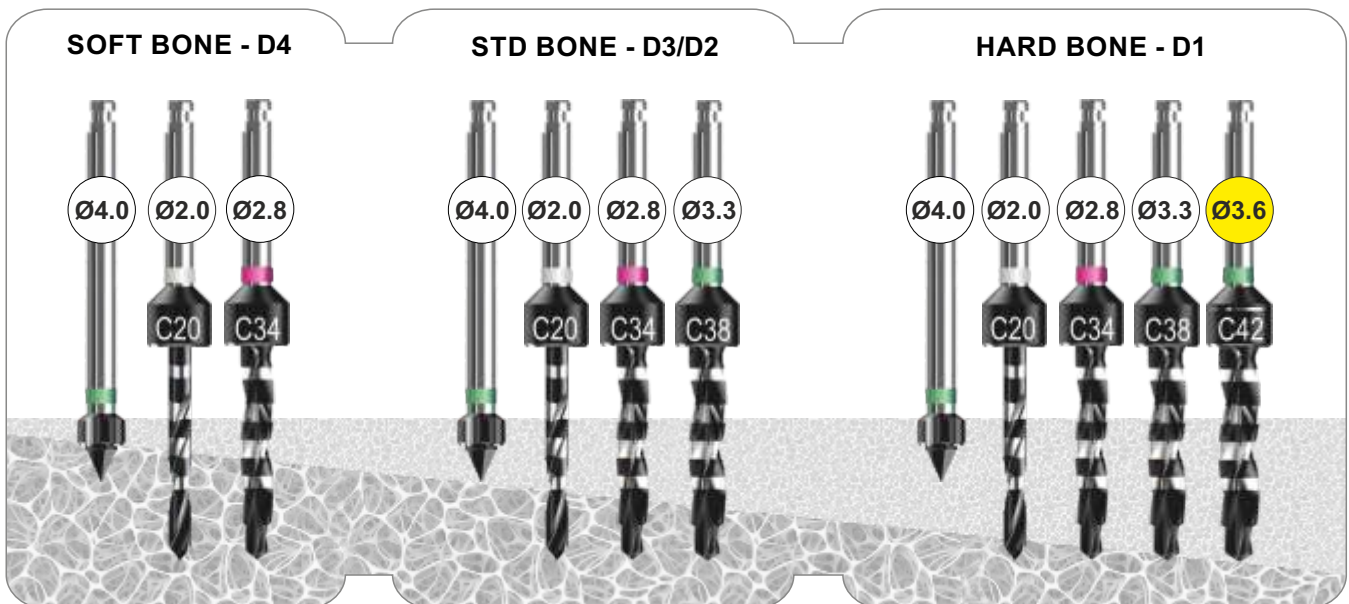
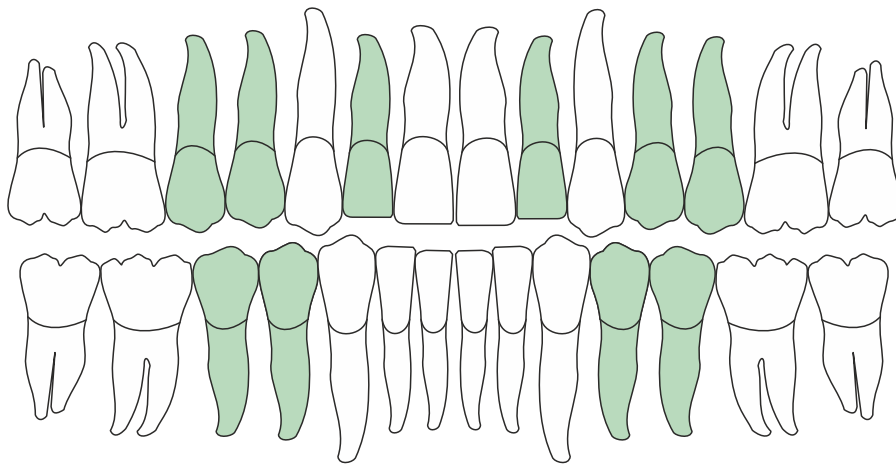
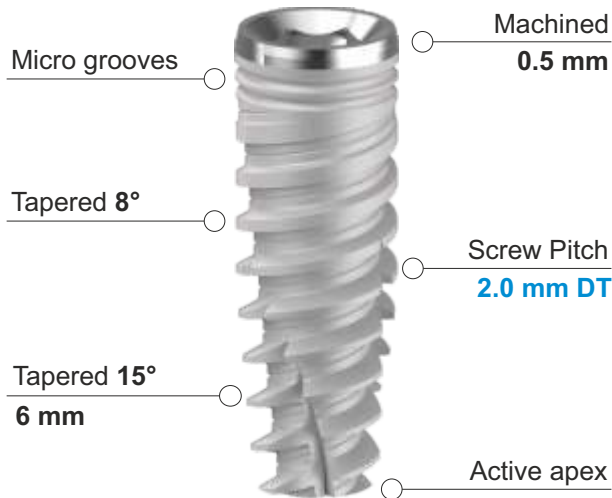

Velocità di rotazione frese consigliata 500 - 800 rpm

Recommended milling burs rotation speed 500 - 800 rpm

3.8 Full Treatment - With Mounter



CODE	IMPLANT	LENGTH	PLATFORM	APEX
IA 3808	Ø 3.8	8.5 mm	Ø 4.0	Ø 2.5
IA 3810	Ø 3.8	10 mm	Ø 4.0	Ø 2.5
IA 3811	Ø 3.8	11.5 mm	Ø 4.0	Ø 2.5
IA 3813	Ø 3.8	13 mm	Ø 4.0	Ø 2.5
IA 3815	Ø 3.8	15 mm	Ø 4.0	Ø 2.5

3.8 Full Treatment - Mounterless



CODE	IMPLANT	LENGTH	PLATFORM	APEX
IA 3808 ML	Ø 3.8	8.5 mm	Ø 4.0	Ø 2.5
IA 3810 ML	Ø 3.8	10 mm	Ø 4.0	Ø 2.5
IA 3811 ML	Ø 3.8	11.5 mm	Ø 4.0	Ø 2.5
IA 3813 ML	Ø 3.8	13 mm	Ø 4.0	Ø 2.5
IA 3815 ML	Ø 3.8	15 mm	Ø 4.0	Ø 2.5

EQUICRESTAL



SHALLOW SUBCRESTAL



DEEP SUBCRESTAL



IA 42



ACTIVE BLADE SHAPE Internal Hexagon

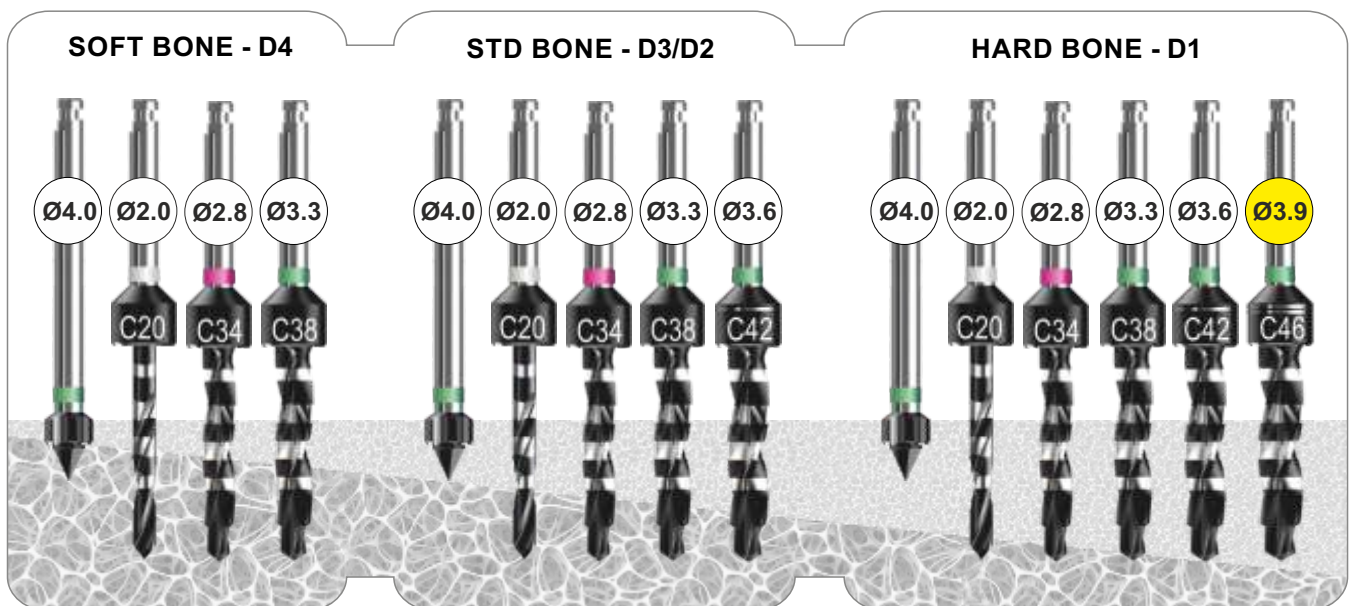
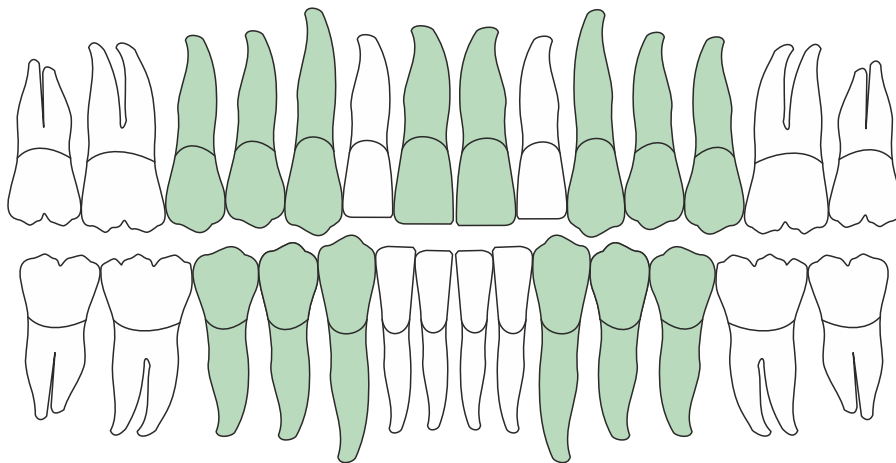
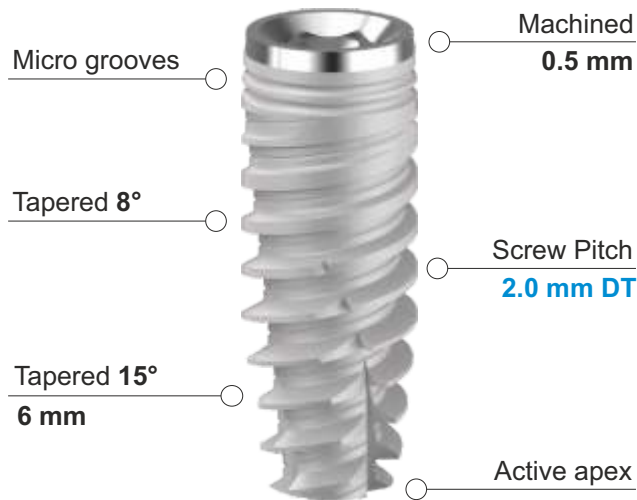

Velocità di rotazione frese consigliata 500 - 800 rpm

Recommended milling burs rotation speed 500 - 800 rpm

4.2 Full Treatment - With Mounter



CODE	IMPLANT	LENGTH	PLATFORM	APEX
IA 4208	Ø 4.2	8.5 mm	Ø 4.0	Ø 2.9
IA 4210	Ø 4.2	10 mm	Ø 4.0	Ø 2.9
IA 4211	Ø 4.2	11.5 mm	Ø 4.0	Ø 2.9
IA 4213	Ø 4.2	13 mm	Ø 4.0	Ø 2.9
IA 4215	Ø 4.2	15 mm	Ø 4.0	Ø 2.9

4.2 Full Treatment - Mounterless



CODE	IMPLANT	LENGTH	PLATFORM	APEX
IA 4208 ML	Ø 4.2	8.5 mm	Ø 4.0	Ø 2.9
IA 4210 ML	Ø 4.2	10 mm	Ø 4.0	Ø 2.9
IA 4211 ML	Ø 4.2	11.5 mm	Ø 4.0	Ø 2.9
IA 4213 ML	Ø 4.2	13 mm	Ø 4.0	Ø 2.9
IA 4215 ML	Ø 4.2	15 mm	Ø 4.0	Ø 2.9

THE RIGHT POST-EXTRACTION SURGICAL TECHNIQUE



IA 46



ACTIVE BLADE SHAPE Internal Hexagon

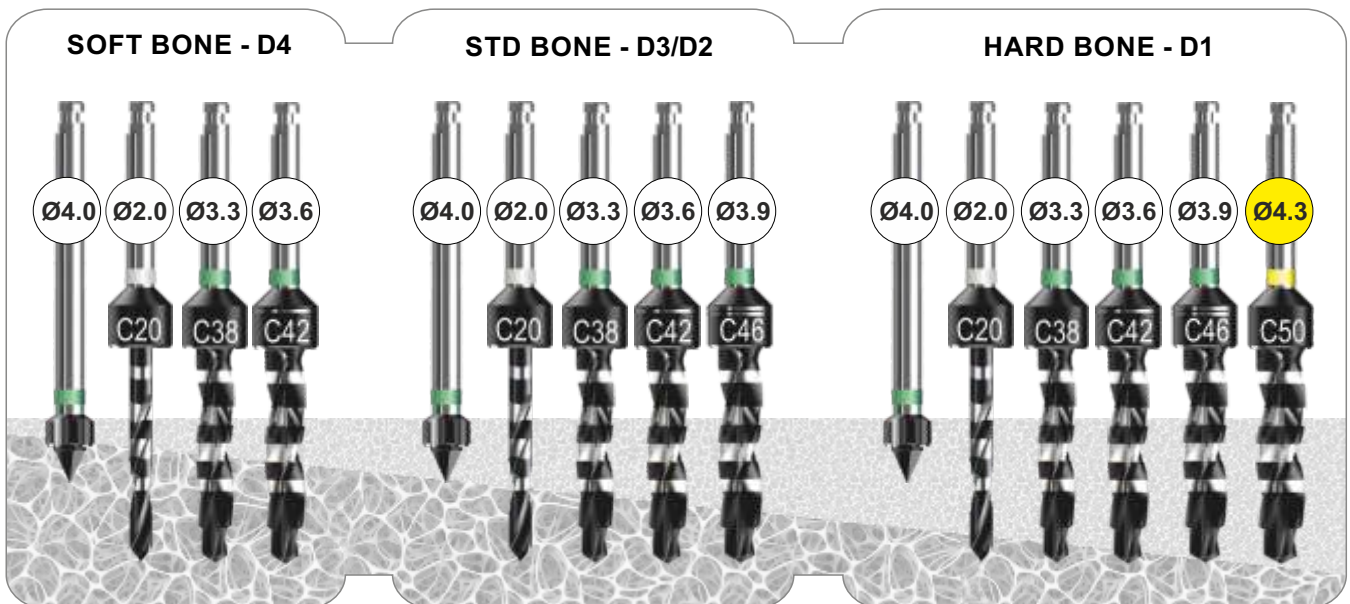
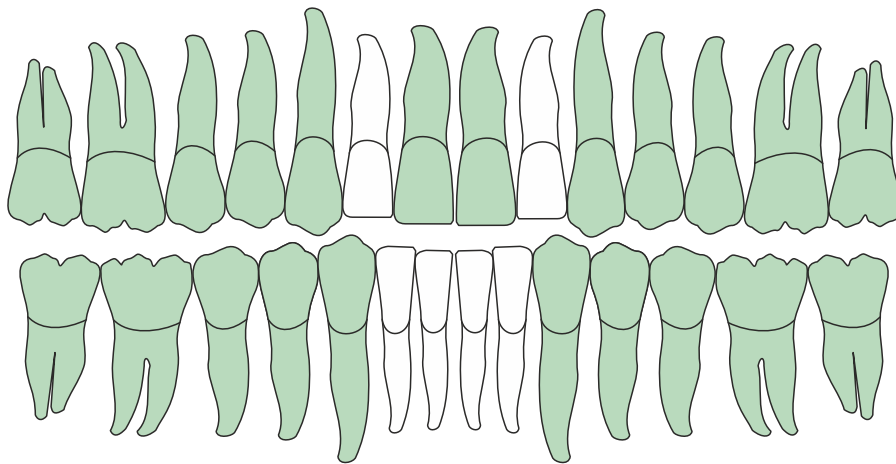
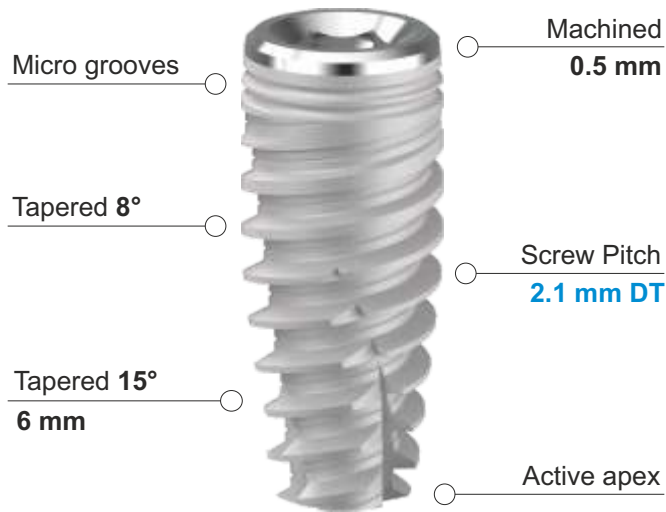

Velocità di rotazione frese consigliata 500 - 800 rpm

Recommended milling burs rotation speed 500 - 800 rpm

4.6 Full Treatment - With Mounter



CODE	IMPLANT	LENGTH	PLATFORM	APEX
IA 4608	Ø 4.6	8.5 mm	Switch Ø 4.0	Ø 3.3
IA 4610	Ø 4.6	10 mm	Switch Ø 4.0	Ø 3.3
IA 4611	Ø 4.6	11.5 mm	Switch Ø 4.0	Ø 3.3
IA 4613	Ø 4.6	13 mm	Switch Ø 4.0	Ø 3.3
IA 4615	Ø 4.6	15 mm	Switch Ø 4.0	Ø 3.3

4.6 Full Treatment - Mounterless



CODE	IMPLANT	LENGTH	PLATFORM	APEX
IA 4608 ML	Ø 4.6	8.5 mm	Switch Ø 4.0	Ø 3.3
IA 4610 ML	Ø 4.6	10 mm	Switch Ø 4.0	Ø 3.3
IA 4611 ML	Ø 4.6	11.5 mm	Switch Ø 4.0	Ø 3.3
IA 4613 ML	Ø 4.6	13 mm	Switch Ø 4.0	Ø 3.3
IA 4615 ML	Ø 4.6	15 mm	Switch Ø 4.0	Ø 3.3

Oneabutment Octa 3.8



Oneabutment Octa 4.8



IA 50



ACTIVE BLADE SHAPE Internal Hexagon

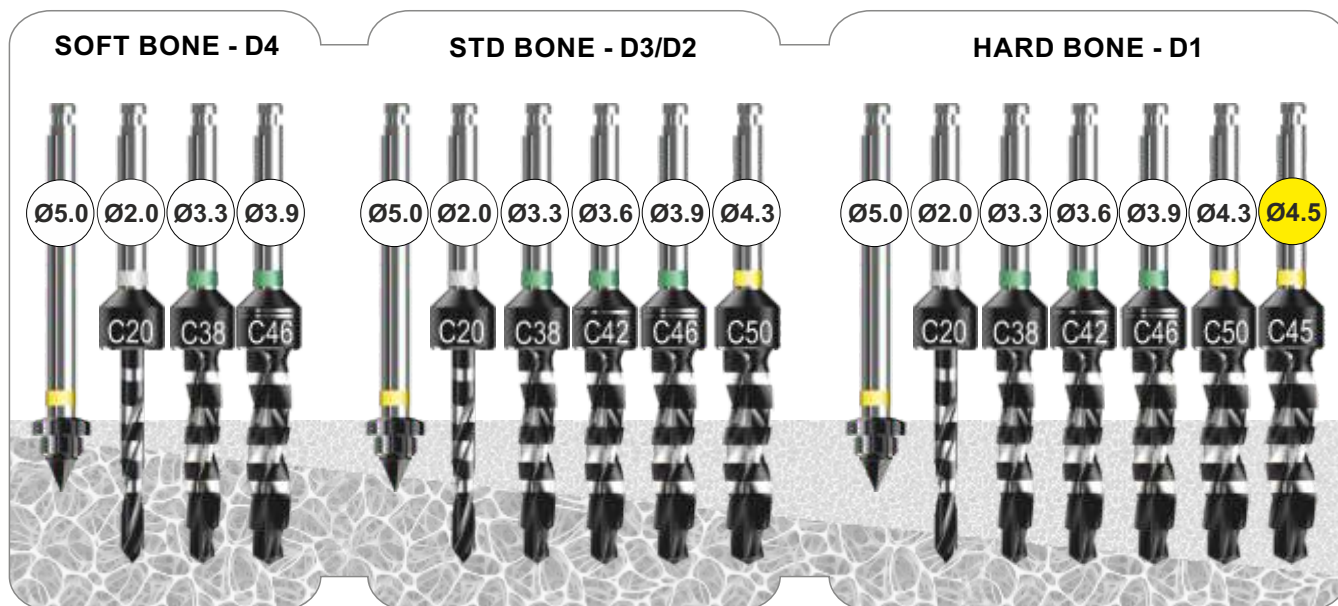
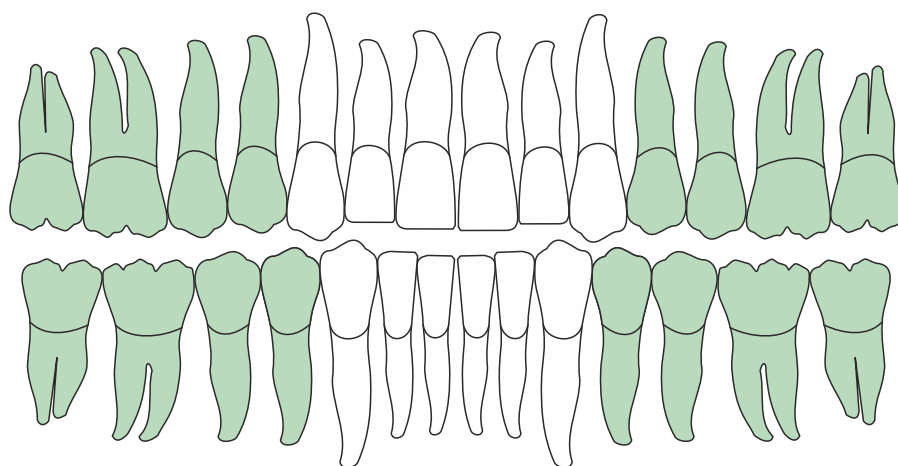
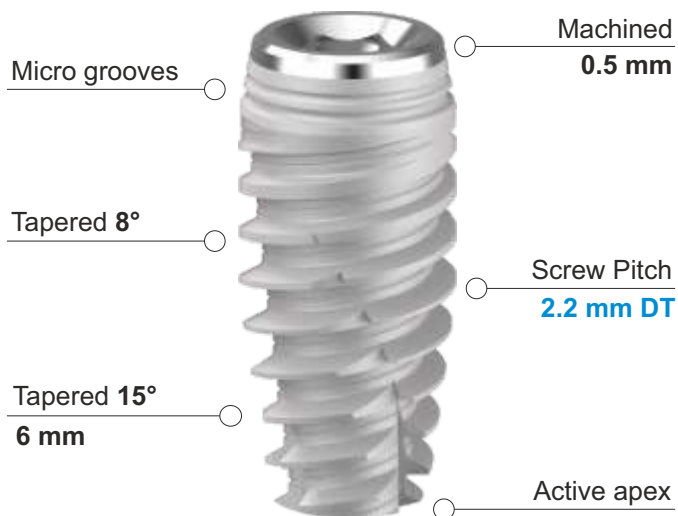

Velocità di rotazione frese consigliata 500 - 800 rpm

Recommended milling burs rotation speed 500 - 800 rpm

5.0 Full Treatment - With Mounter



CODE	IMPLANT	LENGTH	PLATFORM	APEX
IA 5008	Ø 5.0	8.5 mm	Switch Ø 4.0	Ø 3.7
IA 5010	Ø 5.0	10 mm	Switch Ø 4.0	Ø 3.7
IA 5011	Ø 5.0	11.5 mm	Switch Ø 4.0	Ø 3.7
IA 5013	Ø 5.0	13 mm	Switch Ø 4.0	Ø 3.7

5.0 Full Treatment - Mounterless



CODE	IMPLANT	LENGTH	PLATFORM	APEX
IA 5008 ML	Ø 5.0	8.5 mm	Switch Ø 4.0	Ø 3.7
IA 5010 ML	Ø 5.0	10 mm	Switch Ø 4.0	Ø 3.7
IA 5011 ML	Ø 5.0	11.5 mm	Switch Ø 4.0	Ø 3.7
IA 5013 ML	Ø 5.0	13 mm	Switch Ø 4.0	Ø 3.7





INTERNAL HEXAGON UNIVERSAL CONNECTION

CYLINDRICAL
SHAPE



IC

IC 38



CYLINDRICAL SHAPE Internal Hexagon

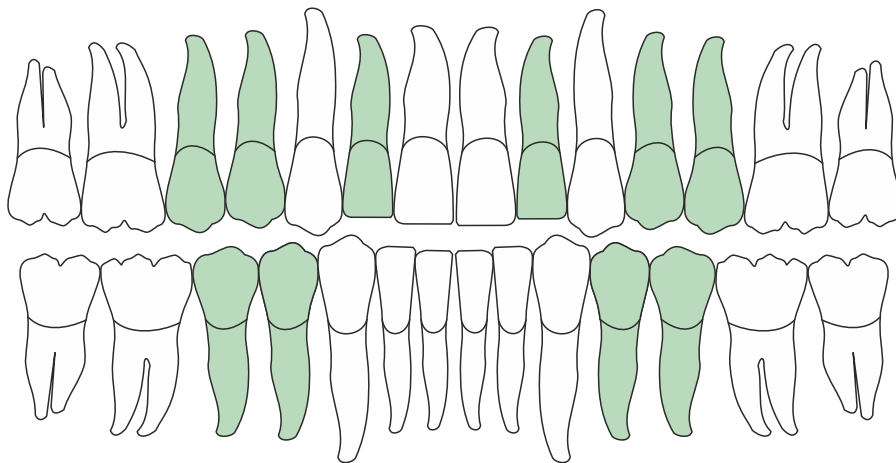
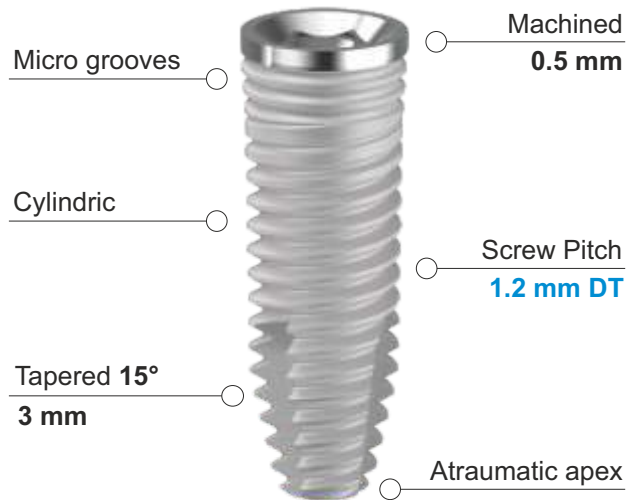

SOFT BONE - D4



STD BONE - D3/D2



HARD BONE - D1

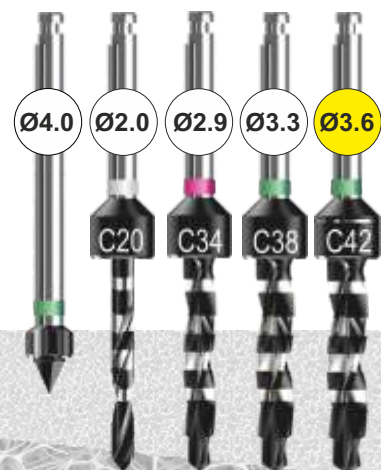

Velocità di rotazione frese consigliata 500 - 800 rpm

Recommended milling burs rotation speed 500 - 800 rpm

IC 42



CYLINDRICAL SHAPE Internal Hexagon

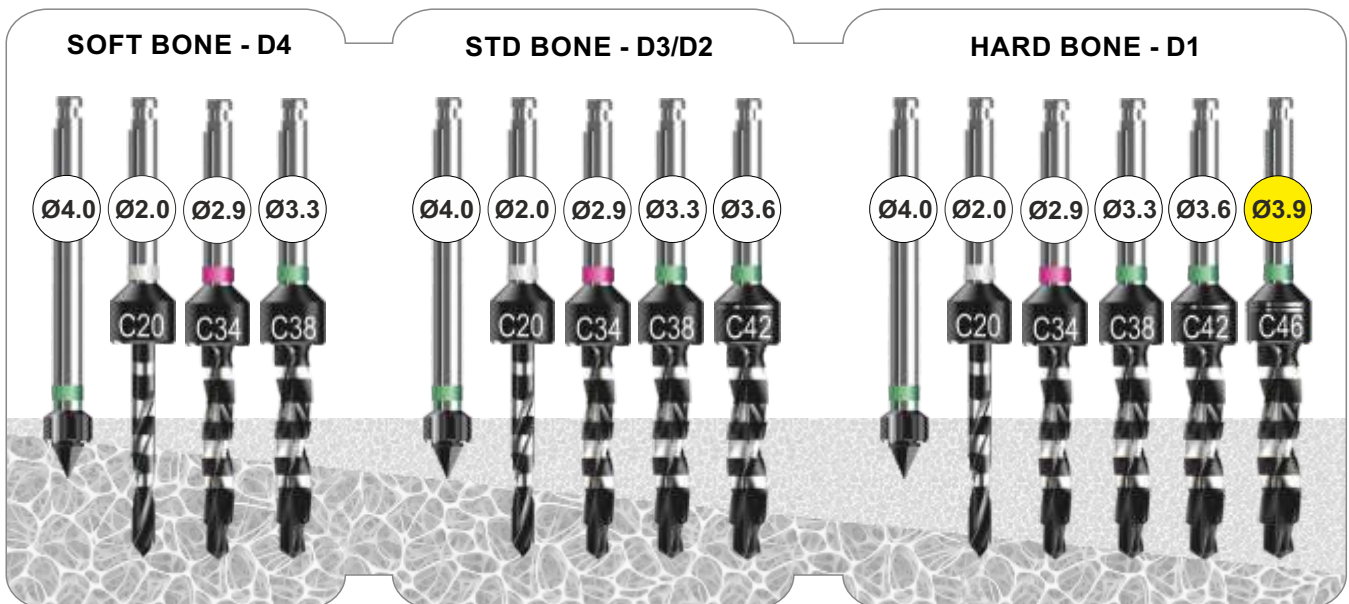
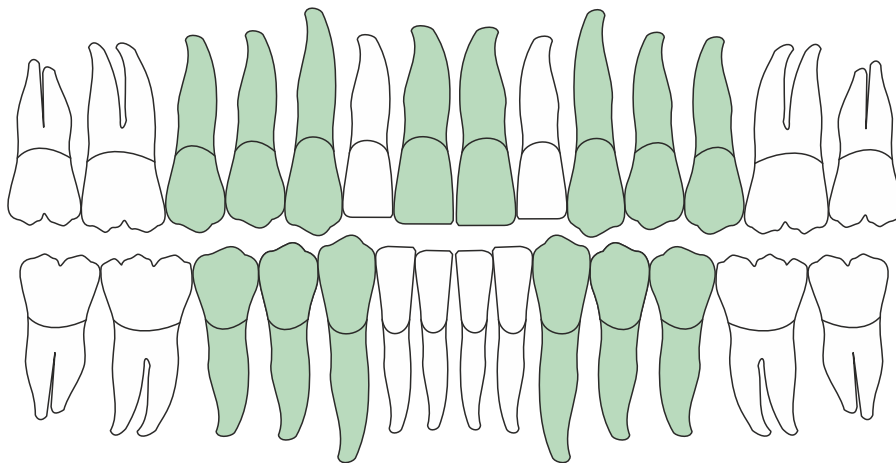
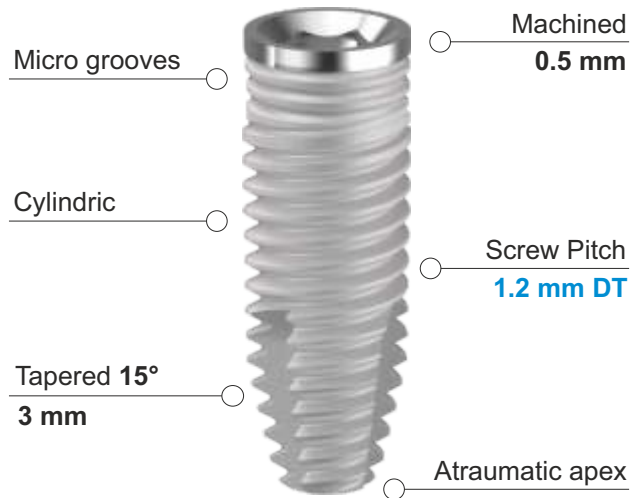

Velocità di rotazione frese consigliata 500 - 800 rpm

Recommended milling burs rotation speed 500 - 800 rpm

3.8 Full Treatment - With Mounter



CODE	IMPLANT	LENGTH	PLATFORM	APEX
IC 3808	Ø 3.8	8.5 mm	Ø 4.0	Ø 1.9
IC 3810	Ø 3.8	10 mm	Ø 4.0	Ø 1.9
IC 3811	Ø 3.8	11.5 mm	Ø 4.0	Ø 1.9
IC 3813	Ø 3.8	13 mm	Ø 4.0	Ø 1.9
IC 3815	Ø 3.8	15 mm	Ø 4.0	Ø 1.9

4.2 Half Treatment - With Mounter



CODE	IMPLANT	LENGTH	PLATFORM	APEX
IC 4208	Ø 4.2	8.5 mm	Ø 4.0	Ø 2.15
IC 4210	Ø 4.2	10 mm	Ø 4.0	Ø 2.15
IC 4211	Ø 4.2	11.5 mm	Ø 4.0	Ø 2.15
IC 4213	Ø 4.2	13 mm	Ø 4.0	Ø 2.15



IC 46



CYLINDRICAL SHAPE Internal Hexagon

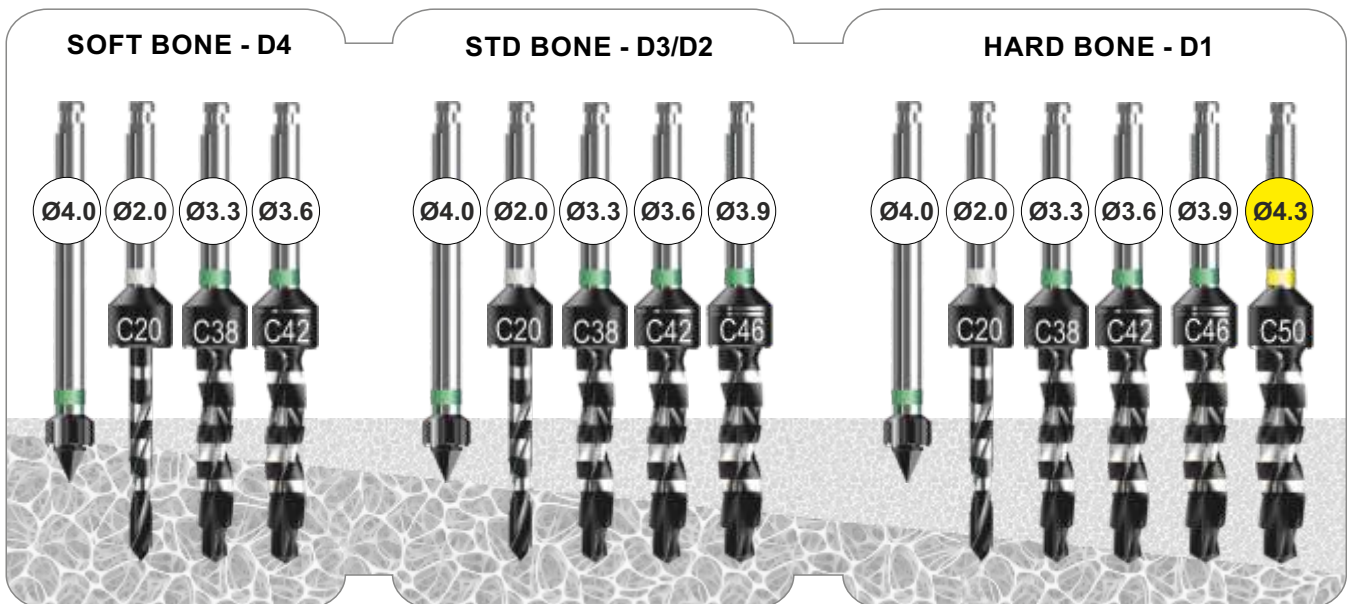
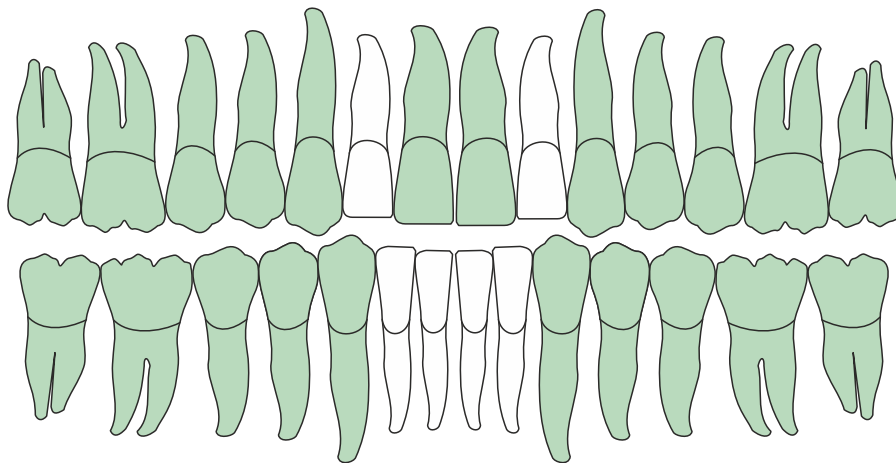
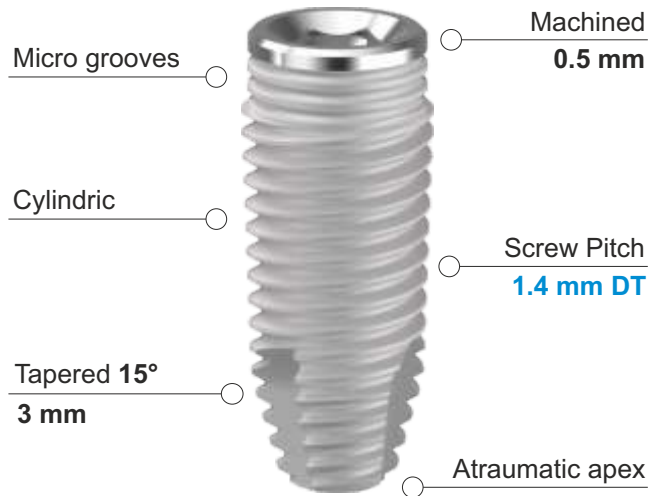

Velocità di rotazione frese consigliata 500 - 800 rpm

Recommended milling burs rotation speed 500 - 800 rpm

IC 50



LARGE CYLINDRICAL SHAPE Internal Hexagon

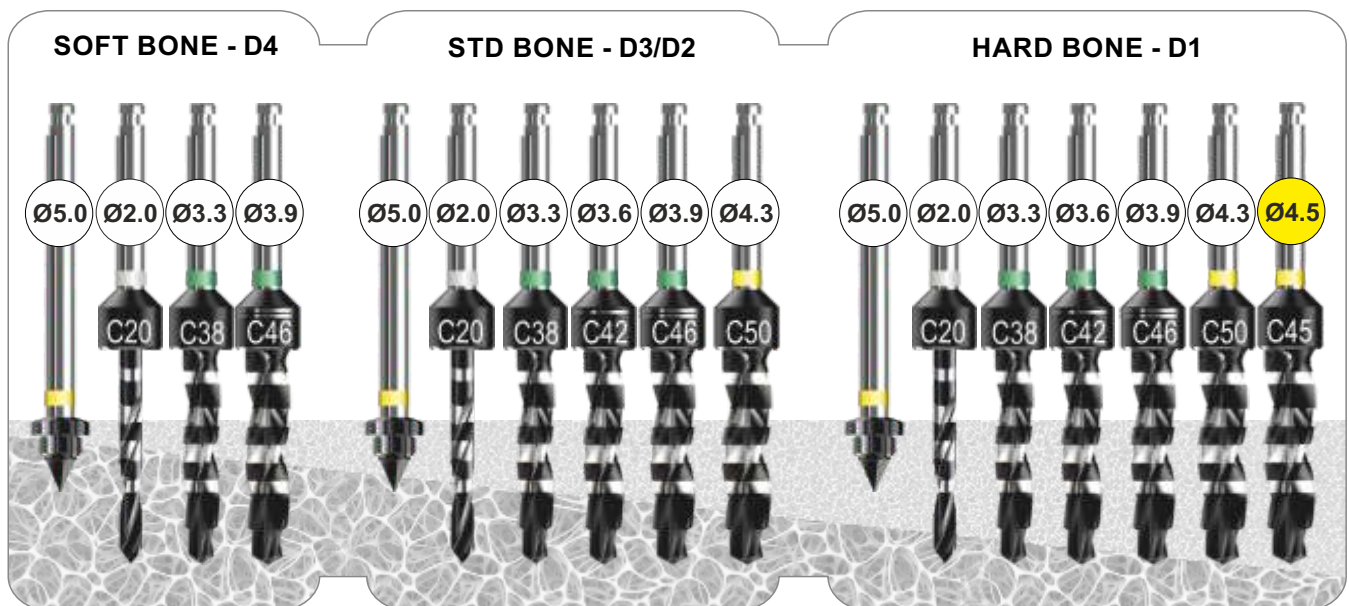
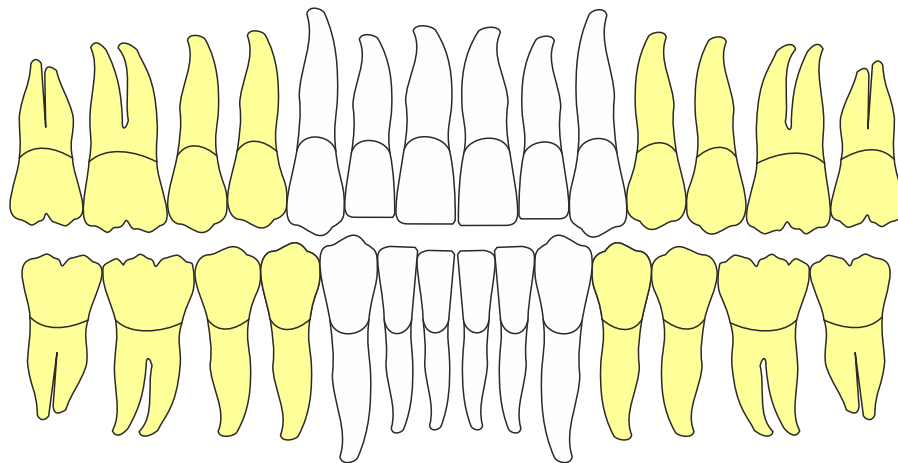
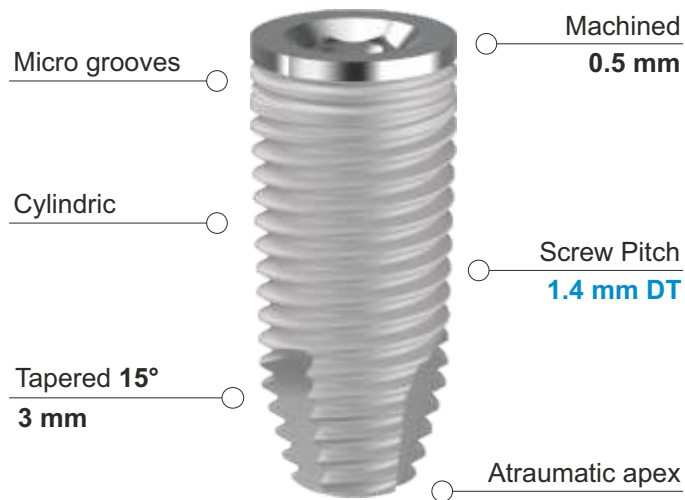

Velocità di rotazione frese consigliata 500 - 800 rpm

Recommended milling burs rotation speed 500 - 800 rpm

4.6 Full Treatment - With Mounter



CODE	IMPLANT	LENGTH	PLATFORM	APEX
IC 4608	Ø 4.6	8.5 mm	Ø 4.2	Ø 2.6
IC 4610	Ø 4.6	10 mm	Ø 4.2	Ø 2.6
IC 4611	Ø 4.6	11.5 mm	Ø 4.2	Ø 2.6
IC 4613	Ø 4.6	13 mm	Ø 4.2	Ø 2.6
IC 4615	Ø 4.6	15 mm	Ø 4.2	Ø 2.6

5.0 Full Treatment - With Mounter



CODE	IMPLANT	LENGTH	PLATFORM	APEX
IC 5008	Ø 5.0	8.5 mm	Ø 5.0	Ø 3.2
IC 5010	Ø 5.0	10 mm	Ø 5.0	Ø 3.2
IC 5011	Ø 5.0	11.5 mm	Ø 5.0	Ø 3.2
IC 5013	Ø 5.0	13 mm	Ø 5.0	Ø 3.2





INTERNAL HEXAGON UNIVERSAL CONNECTION

UNIVERSAL PROSTHETICS



CPS Conical Platform Switching



CONNESSIONE CPS RESISTA

La connessione esagonale interna CPS prevede un doppia possibilità di protesizzazione che meglio si adatta alle differenti scuole di pensiero protesico.

- 1 La piattaforma esterna piana (flat to flat) è ideale per le soluzioni protesiche multi-impianto solidarizzate ed avvitate (tipo Toronto).
- 2 La piattaforma interna conica 45° (platform switching) è ideale per le soluzioni protesiche singole avvitate testa impianto o cementate su abutment singoli/multipli (ponti e corone).

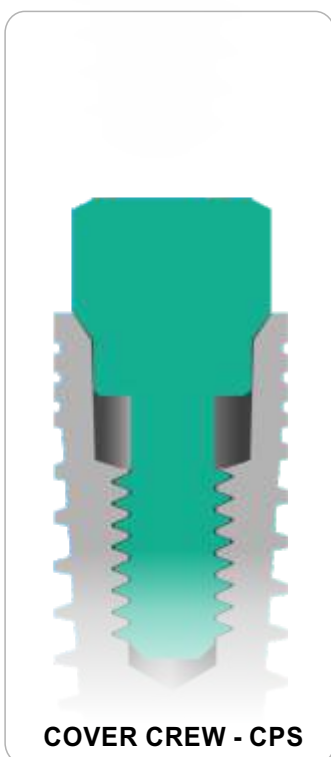
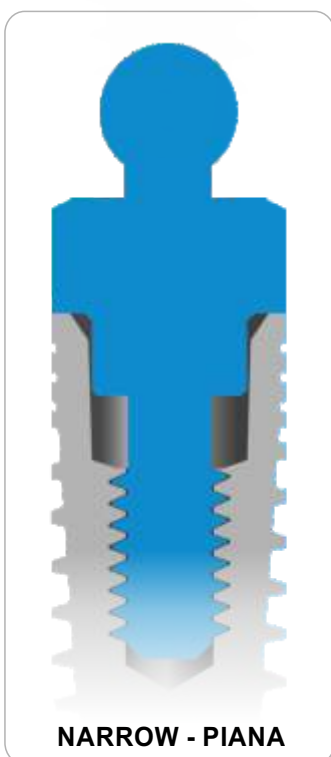
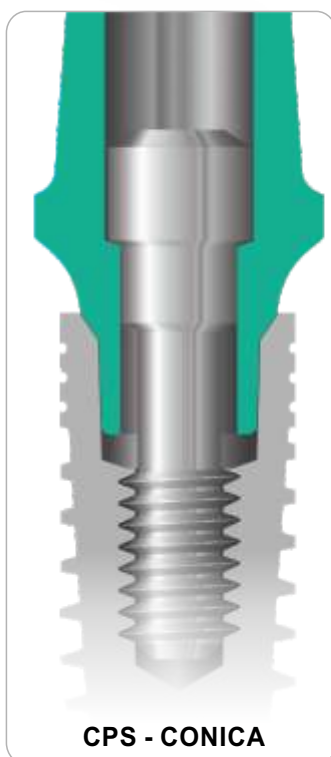
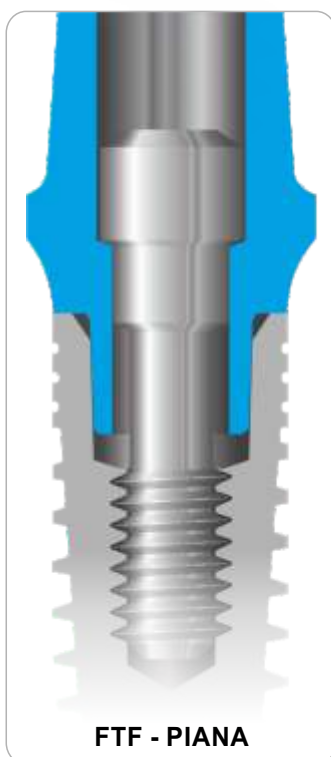

universal prosthetics

Pilastro di Guarigione CPS - Titanio Gr. 5 - Anodizzato

CPS Healing Abutment - Titanium Gr. 5 - Anodized

- IP 4HA2-W H 2 mm - **CPS** Standard Gingival Profile
- IP 4HA4-W H 4 mm - **CPS** Standard Gingival Profile
- IP 4HA6-W H 6 mm - **CPS** Standard Gingival Profile
- IP 4HA7-W H 7.5 mm - **CPS** Standard Gingival Profile

DM 1/2 Standard Hexagonal Driver Ø 1.27

 20Ncm



Pilastro di Guarigione FTF - Titanio Gr. 5 - Anodizzato

FTF Healing Abutment - Titanium Gr. 5 - Anodized

- IP 4HA2 H 2 mm - **FTF** Standard Gingival Profile
- IP 4HA4 H 4 mm - **FTF** Standard Gingival Profile
- IP 4HA6 H 6 mm - **FTF** Standard Gingival Profile

DM 1/2 Standard Hexagonal Driver Ø 1.27

 20Ncm



Pilastro di Guarigione Largo FTF - Titanio Gr. 5 - Anodizzato

FTF Large Healing Abutment - Titanium Gr. 5 - Anodized

- IP 4HA2-E H 2 mm - **FTF** Large Gingival Profile
- IP 4HA4-E H 4 mm - **FTF** Large Gingival Profile
- IP 4HA6-E H 6 mm - **FTF** Large Gingival Profile

DM 1/2 Standard Hexagonal Driver Ø 1.27

 20Ncm



Vite Chirurgica di Copertura CPS - Titanio Gr. 4

CPS Cover Screw - Titanium Gr. 4

- IP 4CS1 CPS Cover Screw - 1.5mm - Narrow Gingival Profile
- IP 4CS3 CPS Cover Screw - 3.0mm - Narrow Gingival Profile
- IP 4CS5 CPS Cover Screw - 5.0mm - Narrow Gingival Profile

DM 1/2 Standard Hexagonal Driver Ø 1.27

 20Ncm



Incremento gengivale per rimodellamento con provvisori e recupero facilitato di impianti in posizione sub-crestale

universal prosthetics



Moncone Calcinabile CPS - Acrilico
CPS Castable Abutment - Acrylic

IP 4CA-W Antirotation Hex - **CPS** Standard Gingival Profile
IP 4CR-W Rotating - **CPS** Standard Gingival Profile

IP VITG Vite di Ricambio Gold - Gold Spare Screw
DM 1/2 Standard Hexagonal Driver Ø 1.27



Moncone Calcinabile FTF - Acrilico
FTF Castable Abutment - Acrylic

IP 4CA Antirotation Hex - **FTF** Standard Gingival Profile
IP 4CR Rotating - **FTF** Standard Gingival Profile

IP VITG Vite di Ricambio Gold - Gold Spare Screw
DM 1/2 Standard Hexagonal Driver Ø 1.27



Moncone UCLA Cobalto Cromo - CoCr
UCLA Abutment Cobalt Chrome - CoCr

IP 4CCA-W Antirotation Hex - **CPS** Standard Gingival Profile
IP 4CCR-W Rotating - **CPS** Standard Gingival Profile

Intervallo di Fusione 1350°-1430° Esp. Termica 13,3 - 13,6 µm/(m*°C) (20°-200°)

IP VITG Vite di Ricambio Gold - Gold Spare Screw
DM 1/2 Standard Hexagonal Driver Ø 1.27



Moncone Provvisorio Estetico - PEEK Medica
Aesthetic Temporary Abutment - Medical PEEK

IP 4PA Antirotation Hex - Standard Gingival Profile

IP VITG Vite di Ricambio Gold - Gold Spare Screw
DM 1/2 Standard Hexagonal Driver Ø 1.27



Transfer per impronta Pick Up - Titanio Gr. 5
Pick Up Impression Coping - Titanium Gr. 5

IP X40-W H 12mm - Internal Hexagon CPS

DM 1/2 Standard Hexagonal Driver Ø 1.27

1 Vite Lunga
 2 Tubetto con Esagono
 3

universal prosthetics

Pilastri Temporanei da Incollaggio - Titanio Gr. 5

Temporary Glueing Abutments - Titanium Gr. 5

IP 4TA-W Temporary Glueing Abutment - Antirotation Hex

IP 4TR-W Temporary Glueing Abutment - Rotating

IP VITG Vite di Ricambio Gold - Gold Spare Screw

DM 1/2 Standard Hexagonal Driver Ø 1.27



Pilastro Temporaneo da Saldatura - Titanio Gr. 5

Temporary Welding Abutments - Titanium Gr. 5

IP 4TRS Temporary Welding Abutment - Rotating

IP VITG Vite di Ricambio Gold - Gold Spare Screw

DM 1/2 Standard Hexagonal Driver Ø 1.27



Moncone Titanio Diritto - Titanio Gr. 5 - PVD TiN

Straight Titanium Abutment - Titanium Gr. 5 - PVD TiN

IP 4ST2-W 0° - Straight - **CPS** Standard Gingival Profile

IP VITG Vite di Ricambio Gold - Gold Spare Screw

DM 1/2 Standard Hexagonal Driver Ø 1.27



Moncone Titanio Angolato - Titanio Gr. 5 - PVD TiN

Angled Titanium Abutment - Titanium Gr. 5 - PVD TiN

IP 4AT15-W 15° - Angled - **CPS** Standard Gingival Profile

IP 4AT25-W 25° - Angled - **CPS** Standard Gingival Profile

IP VITG Vite di Ricambio Gold - Gold Spare Screw

DM 1/2 Standard Hexagonal Driver Ø 1.27



Moncone Titanio Diritto VPT - Titanio Gr. 5

VPT Straight Titanium Abutment - Titanium Gr. 5

IP 4STV-W 0° - Straight - **CPS** Standard Gingival Profile

IP VIT Vite di Ricambio - Spare Screw

DM 1/2 Standard Hexagonal Driver Ø 1.27



Vertical Preparation Technique

double connection friction fit 1.5°

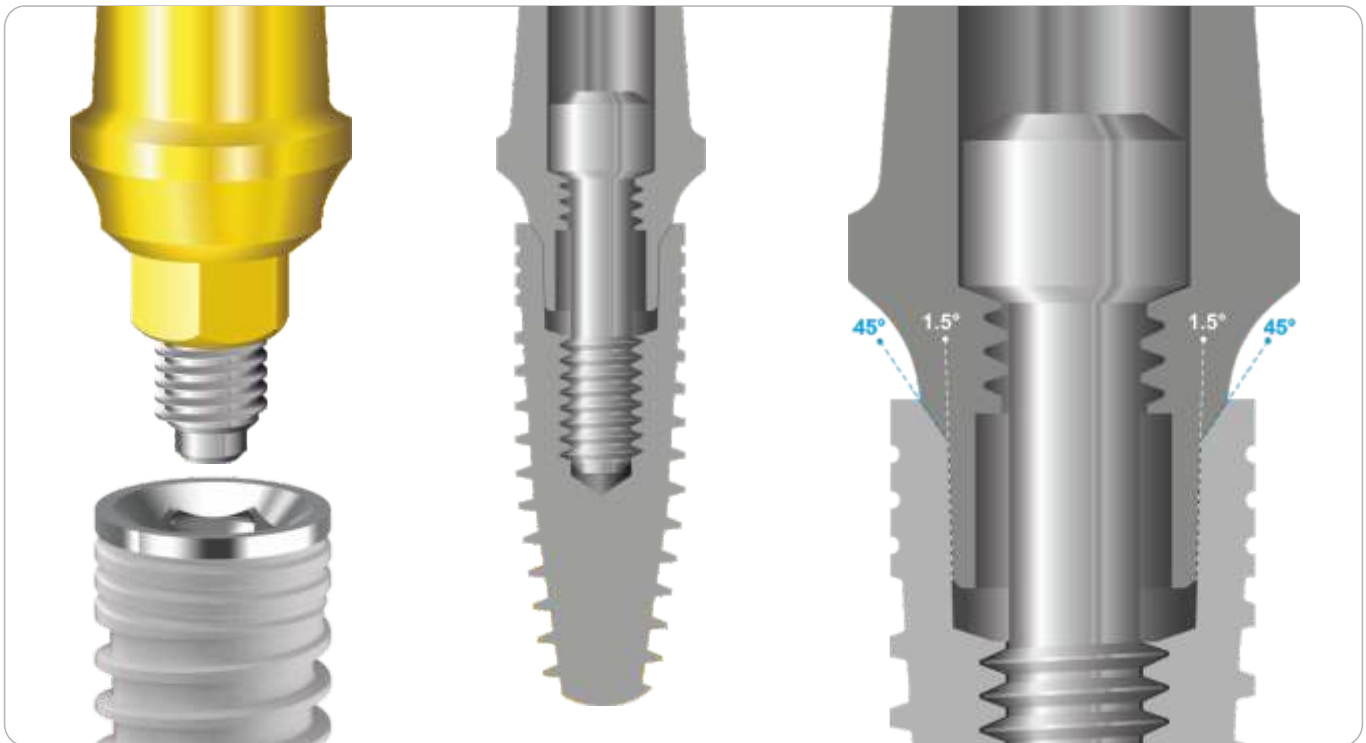

32Ncm



Moncone Titanio Dritto - Titanio Gr. 5 - PVD TiN

Straight Titanium Abutment - Titanium Gr. 5 - PVD TiN

IP 4ST2-WF 0° - Straight H2mm - **CPS** Friction Fit

IP 4ST3-WF 0° - Straight H3.5mm - **CPS** Friction Fit

IP 5ST2-F 0° - Straight H2mm (Large) - **FTF** Friction Fit

IP VITG

Vite di Ricambio Gold - Gold Spare Screw

DM 1/2

Standard Hexagonal Driver Ø 1.27

32Ncm



Moncone in Titanio Angolato 15° - Titanio Gr. 5 - PVD TiN

15° Angled Titanium Abutment - Titanium Gr. 5 - PVD TiN

IP 4AT152-WF 15° Angled H2mm - **CPS** Friction Fit

IP 4AT153-WF 15° Angled H3mm - **CPS** Friction Fit

IP 5ST152-F 15° - Angled H2mm (Large) - **FTF** Friction Fit

IP VITG

Vite di Ricambio Gold - Gold Spare Screw

DM 1/2

Standard Hexagonal Driver Ø 1.27

32Ncm



Moncone in Titanio Angolato 25° - Titanio Gr. 5 - PVD TiN

25° Angled Titanium Abutment - Titanium Gr. 5 - PVD TiN

IP 4AT252-WF 25° Angled H2mm - **CPS** Friction Fit

IP 4AT253-WF 25° Angled H3mm - **CPS** Friction Fit

IP 5ST252-F 25° - Angled H2mm (Large) - **FTF** Friction Fit

IP VITG

Vite di Ricambio Gold - Gold Spare Screw

DM 1/2

Standard Hexagonal Driver Ø 1.27

double connection friction fit 1.5°

CHIUSURA SPALLA CONICA 45°

L'appoggio protesico interno a 45°, già utilizzato nelle connessioni interne tipo Zimmer dagli anni 90, oltre ad avere un supporto bibliografico indiscutibile, garantisce la distribuzione delle forze vettoriali che minimizzano il momento flettente laterale.

Questa tipologia di appoggio conico, normalmente utilizzata nella meccanica di distribuzione, rispetto ad uno piano, incrementa la superficie di contatto e scarica le forze su una curva di vettori multi-direzionali.

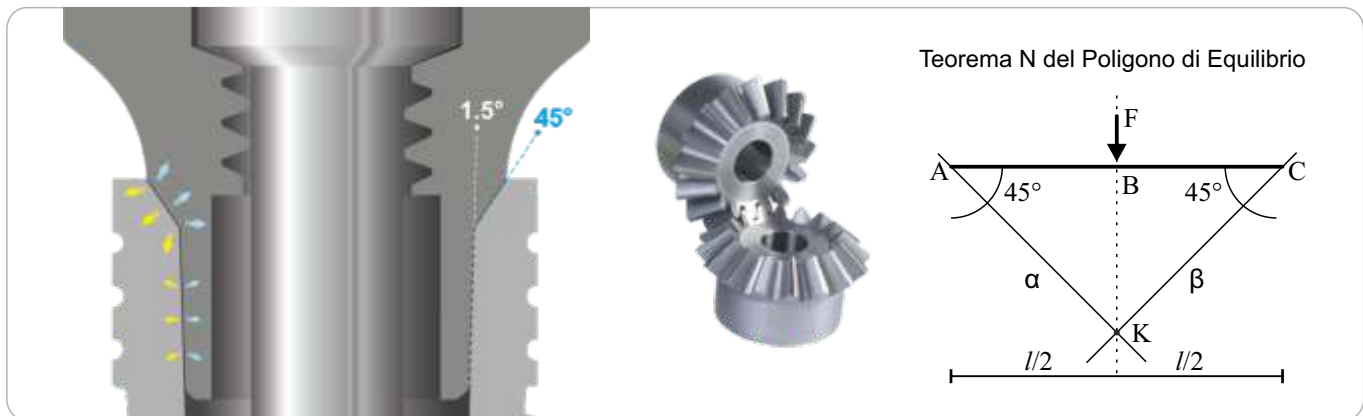

CONNESSIONE ESAGONALE CONICA FRICTION FIT 1.5°

La conicità di 1.5° sulle pareti piane dell'esagono maschio/femmina determina una riduzione dell'interfaccia meccanica così intima da conferire un grippaggio diretto, conosciuto come «saldatura a freddo», tra abutment ed impianto.

Questo effetto si attiva completamente alla fine del serraggio protesico della vite passante, raggiungendo i 30 Ncm di forza torcente che garantisce il sigillo batterico riducendo a zero il gap di interfaccia.

Per la rimozione dell'abutment sarà necessario l'utilizzo di una vite di rimozione alternativa, da avvitare in sostituzione di quella originale, con la sola funzione di spingere dall'interno verticalmente il moncone e rimuoverlo dalla sua posizione grippata.



45° CONICAL SHOULDER CLOSURE

The 45° internal prosthetic support, already used in internal Zimmer type connections since the 90s, has an indisputable bibliography and moreover guarantees the distribution of vector forces that minimize the lateral bending moment.

This type of conical support, normally used in the distribution mechanics, increases the contact surface in relation to a plane surface and releases the forces on a curve of multi-directional vectors.

FRICTION FIT 1.5° CONICAL HEX CONNECTION

The 1.5° conicity on the flat surfaces of the male / female hexagon causes a so close reduction of the mechanical interface that confers a direct binding (known as "cold welding") between the abutment and the implant.

This effect is fully activated at the end of the prosthetic tightening of the passing screw, that reaches 30 Ncm of torque and guarantees a bacterial seal through the reduction of the interface gap to zero.

In order to remove the abutment it will be necessary to use an alternative removal screw, that needs to be screwed in the original one place: its unique function is to push the abutment from the inside vertically and to remove it from its bound position.

Transfer per Impronta Digitale - Titanio Gr. 5 + MS
Scan Abutment - Titanium Gr. 5 + Micro Sandblasting

IP 4SA2 DS Antirotation Hex - **Narrow** Gingival Profile

DM 1/2 Standard Hexagonal Driver Ø 1.27



Analogo CAD da Laboratorio - Titanio Gr. 5
Laboratory CAD Analog - Titanium Gr. 5

IP 4AL2 DS H 12 mm - Universal Shape - Whit screw
IP 4AL2DS-V H 12 mm - Universal Shape - Whitout screw

DM 1/2 Standard Hexagonal Driver Ø 1.27



Link Base per Incollaggio - Titanio Gr. 5
Bonding Technique Base Link - Titanium Gr. 5

IP 4TB0 DS-W Gingival Profile **H 0.3mm** - Antirotation Hex
IP 4TBR0 DS-W Gingival Profile **H 0.3mm** - Rotanting

IP VITG Vite di Ricambio Gold - Gold Spare Screw
DM 1/2 Standard Hexagonal Driver Ø 1.27

Adjustable in 3 heights

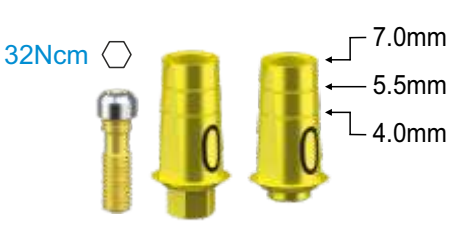

Link Base per Incollaggio - Titanio Gr. 5
Bonding Technique Base Link - Titanium Gr. 5

IP 4TB1 DS-W Gingival Profile **H 1.5mm** - Antirotation Hex
IP 4TBR1 DS-W Gingival Profile **H 1.5mm** - Rotanting

IP VITG Vite di Ricambio Gold - Gold Spare Screw
DM 1/2 Standard Hexagonal Driver Ø 1.27

Adjustable in 3 heights



Link Base per Incollaggio - Titanio Gr. 5
Bonding Technique Base Link - Titanium Gr. 5

IP 4TB2 DS-W Gingival Profile **H 2.5mm** - Antirotation Hex
IP 4TBR2 DS-W Gingival Profile **H 2.5mm** - Rotanting

IP VITG Vite di Ricambio Gold - Gold Spare Screw
DM 1/2 Standard Hexagonal Driver Ø 1.27

Adjustable in 3 heights



universal prosthetics

Link per Incollaggio - Compatibile Cerec - Titanio Gr. 5

Bonding Technique Link - Cerec Compatible - Titanium Gr. 5

IP 4STB Digital Titanium Link **H0.5mm** - Antirotation Hex - **FTF**

IP 4STB-W Digital Titanium Link **H0.5mm** - Antirotation Hex - **CPS**

IP 4STB1-W Digital Titanium Link **H1.0mm** - Antirotation Hex - **CPS**

IP 4STB2-W Digital Titanium Link **H2.0mm** - Antirotation Hex - **CPS**

IP 4STB3-W Digital Titanium Link **H3.0mm** - Antirotation Hex - **CPS**

IP 4STBR1-W Digital Titanium Link **H1.0mm** - Rotating - **CPS**

IP 4STBR2-W Digital Titanium Link **H2.0mm** - Rotating - **CPS**

IP 4STBR3-W Digital Titanium Link **H3.0mm** - Rotating - **CPS**

IP VIT Vite di Ricambio - Spare Screw

DM 1/2 Standard Hexagonal Driver \varnothing 1.27



Link Flat Digitale per Incollaggio - Titanio Gr. 5

Flat Digital Link for Bonding Technique - Titanium Gr. 5

IP 4TB DS Flat Titanium Link - Antirotation Hex - H 1.5mm - **FTF**

IP 4TBR DS Flat Titanium Link - Rotating - H 1.5mm - **FTF**

IP VIT Vite di Ricambio - Spare Screw

DM 1/2 Standard Hexagonal Driver \varnothing 1.27



Link Aperti da incollaggio per Avvitamento Angolato - Titanio Gr. 5

Open Links for Gluing for Angled Screwing - Titanium Gr. 5

IP4TBAI0DS-W Gingival Profile **H 0.6mm** - Antirotation Hex

IP4TBAI1DS-W Gingival Profile **H 1.5mm** - Antirotation Hex

IP4TBRAI0DS-W Gingival Profile **H 0.6mm** - Rotating

IP4TBRAI1DS-W Gingival Profile **H 1.5mm** - Rotating

MDT6DS Manual Torque Driver for angled hole

DCT6DS RA Contr-angle Torque Driver for angled hole



Link Analogico per Incollaggio - Titanio Gr. 5

Analogical Link for Bonding Technique - Titanium Gr. 5

IP 4SZB Analogical Titanium Link - Antirotation Hex - **CPS**

IP VIT Vite di Ricambio - Spare Screw

DM 1/2 Standard Hexagonal Driver \varnothing 1.27



oneabutment octa prosthetics

32Ncm



Oneabutment Octa 3.8 - Titanio Gr. 5

Oneabutment Octa 3.8 - Titanium Gr. 5

IP40 381
IP40 382
IP40 383
IP40 384
IP40 385

Oneabutment Transgengivale H1.5 mm
Oneabutment Transgengivale H2.5 mm
Oneabutment Transgengivale H3.5 mm
Oneabutment Transgengivale H4.5 mm
Oneabutment Transgengivale H5.5 mm

DCOCT1

Prolunga da Cricchetto Corta per serraggio Octa

32Ncm



Oneabutment Octa 4.8 - Titanio Gr. 5

Oneabutment Octa 4.8 - Titanium Gr. 5

IP40 481
IP40 482
IP40 483
IP40 484
IP40 485

Oneabutment Transgengivale H1.5 mm
Oneabutment Transgengivale H2.5 mm
Oneabutment Transgengivale H3.5 mm
Oneabutment Transgengivale H4.5 mm
Oneabutment Transgengivale H5.5 mm

DCOCT1

Prolunga da Cricchetto Corta per serraggio Octa

15Ncm



Pilastro di Guarigione Octa - Titanio Gr. 5

Octa Healing Abutment - Titanium Gr. 5

EPHAO 384
EPHAO 484

Healing Cap Octa Ø 3.8 mm
Healing Cap Octa Ø 4.8 mm

DMRP120S

Standard Hexagonal Driver Ø 1.20

25Ncm



Transfer universale per impronta Digitale - Titanio Gr. 5

Universal Scan Abutment - Titanium Gr. 5

EPSAO 38

Scan Abutment Octa Ø 3.8 mm e Ø 4.8 mm

EPVO

Vite di Ricambio - Spare Screw

DMRP120S

Standard Hexagonal Driver Ø 1.20

15Ncm



Transfer universale per impronta Pick Up - Titanio Gr. 5

Universal Pick Up Impression Coping - Titanium Gr. 5

EPIAO 38

Impression Coping Octa Ø 3.8 mm e Ø 4.8 mm

EPVLO

Vite lunga di Ricambio - Long Spare Screw

DMRP120S

Standard Hexagonal Driver Ø 1.20

oneabutment octa prosthetics

Analogo Digitale Octa per Laboratorio - Titanio Gr. 5

Laboratory Octa Digital Analog - Titanium Gr. 5

EPBALO 38DS Analogo Digitale Octa Ø 3.8 mm

EPBALO 48DS Analogo Digitale Octa Ø 4.8 mm

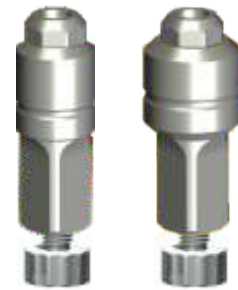

Pilastro Temporaneo Octa - Titanio Gr. 5

Octa Temporary Abutment - Titanium Gr. 5

EPTRO 38 Rotating Temporary Octa Ø 3.8 mm

EPTRO 48 Rotating Temporary Octa Ø 4.8 mm

EPTAO 38 Antirotation Hex Temporary Octa Ø 3.8 mm

EPTAO 48 Antirotation Hex Temporary Octa Ø 4.8 mm



EPVO Vite di Ricambio - Spare Screw

DMRP120S Standard Hexagonal Driver Ø 1.20

Link Base Octa per Incollaggio Basso - Titanio Gr. 5

Short Bonding Technique Octa Base Link - Titanium Gr. 5

EPTRO 380 DS Rotating TiBase Octa Ø 3.8 mm - 0mm

EPTRO 480 DS Rotating TiBase Octa Ø 4.8 mm - 0mm

EPTAO 380 DS Antirotation Hex TiBase Octa Ø 3.8 mm - 0mm

EPTAO 480 DS Antirotation Hex TiBase Octa Ø 4.8 mm - 0mm

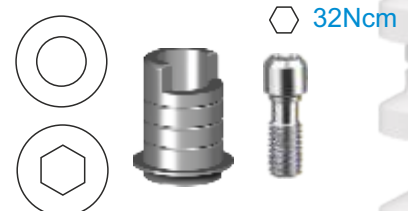

EPVO Vite di Ricambio - Spare Screw

EPVLOT6DS Vite per Canale Angolato - Angled Hole Screw

DMRP120S Standard Hexagonal Driver Ø 1.20

Link Base Octa per Incollaggio Alto - Titanio Gr. 5

High Bonding Technique Octa Base Link - Titanium Gr. 5

EPTRO 38 DS Rotating TiBase Octa Ø 3.8 mm - 3mm

EPTRO 48 DS Rotating TiBase Octa Ø 4.8 mm - 3mm

EPTAO 38 DS Antirotation Hex TiBase Octa Ø 3.8 mm - 3mm

EPTAO 48 DS Antirotation Hex TiBase Octa Ø 4.8 mm - 3mm

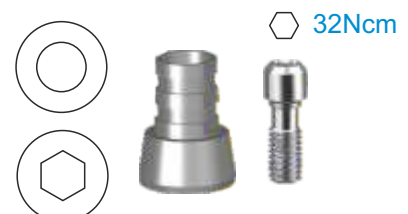

EPVO Vite di Ricambio - Spare Screw

EPVLOT6DS Vite per Canale Angolato - Angled Hole Screw

DMRP120S Standard Hexagonal Driver Ø 1.20

toronto universal prosthetics

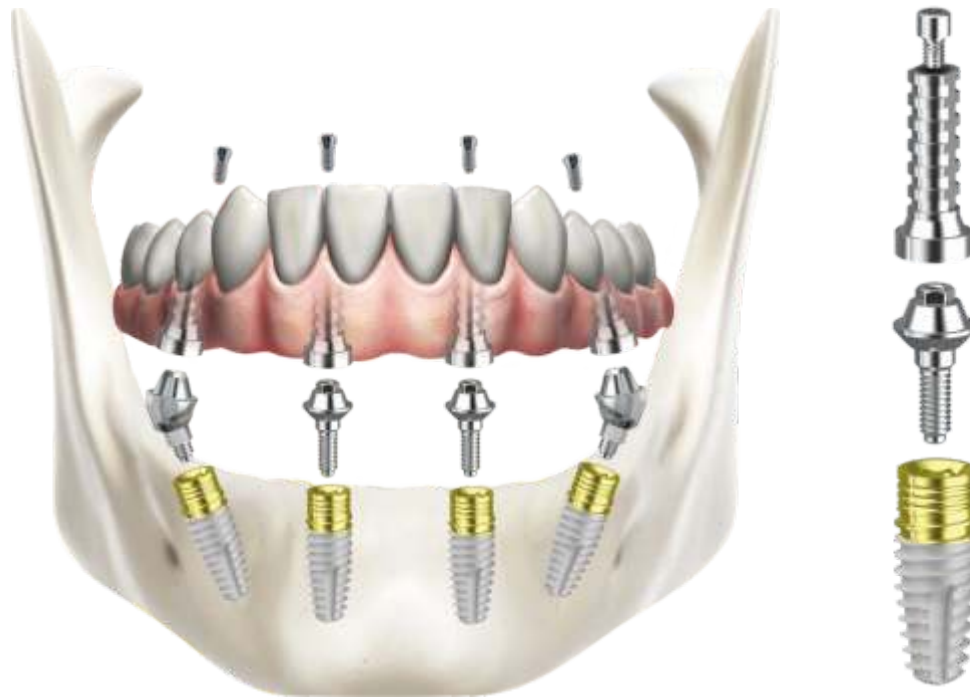

32Ncm



Pilastro Toronto Dritto - Titanio Gr. 5

Toronto Straight Abutment - Titanium Gr. 5

- IP MS1-W** H 1 mm - **CPS** Standard Gingival Profile
- IP MS2-W** H 2 mm - **CPS** Standard Gingival Profile
- IP MS3-W** H 3 mm - **CPS** Standard Gingival Profile

DCDM

Toronto Straight Abutment Driver

32Ncm



Pilastro Toronto Angolato 17° - Titanio Gr. 5

17° Toronto Angled Abutment - Titanium Gr. 5

- IP MA172-W** 17° - H 2 mm - **CPS** Standard Gingival Profile
- IP MA173-W** 17° - H 3 mm - **CPS** Standard Gingival Profile

IP VITMA

Vite di Ricambio Toronto - Toronto Spare Screw

DMX 1/2

Standard Torx Driver

32Ncm



Pilastro Toronto Angolato 30° - Titanio Gr. 5

30° Toronto Angled Abutment - Titanium Gr. 5

- IP MA303-W** 30° - H 3 mm - **CPS** Standard Gingival Profile
- IP MA304-W** 30° - H 4 mm - **CPS** Standard Gingival Profile
- IP MA305-W** 30° - H 5 mm - **CPS** Standard Gingival Profile

IP VITMA

Vite di Ricambio Toronto - Toronto Spare Screw

DMX 1/2

Standard Torx Driver

toronto universal prosthetics

Pilastro Temporaneo Toronto - Titanio Gr. 5

Toronto Temporary Abutment - Titanium Gr. 5

EP MT Rotating - Bonding Technique - Incollaggio Passivo

EP MV Vite di Ricambio Toronto - Toronto Spare Screw

DMX 1/2 Standard Torx Driver



Pilastro Temporaneo Toronto - Titanio Gr. 5

Toronto Temporary Abutment - Titanium Gr. 5

EP MTS Rotating - Welding Technique - Saldatura Intraorale

EP MV Vite di Ricambio Toronto - Toronto Spare Screw

DMX 1/2 Standard Torx Driver



Pilastro Calcinabile Toronto - Acrilico

Toronto Castable Abutment - Acrylic

EP MC Rotating - Standard Gingival Profile

EP MV Vite di Ricambio Toronto - Toronto Spare Screw

DMX 1/2 Standard Torx Driver



Pilastro di Guarigione Toronto

Toronto Healing Abutment

EP MHA H 4 mm - Standard Gingival Profile Titanium Gr5

EP MHA6 H 6 mm - Large Gingival Profile Titanium Gr5

DMX 1/2 Standard Torx Driver



Transfer Toronto - Titanio Gr. 5

Toronto Impression Coping - Titanium Gr. 5

EP MI Rotating - Standard Gingival Profile

EP MVL Vite di Ricambio Toronto L - Toronto L Spare Screw

DMX 1/2 Standard Torx Driver





Transfer Toronto per Impronta Digitale - Titanio Gr. 5
Toronto Scan Abutment - Titanium Gr. 5

EP MSA2 DS Rotating Scan Abutment - Transfer Digitale Rotante

EP MV Vite di Ricambio Toronto - Toronto Spare Screw
DMX 1/2 Standard Torx Driver

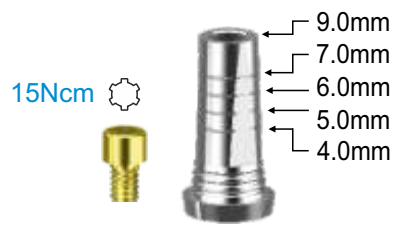

Link Base per Incollaggio - Titanio Gr. 5
Bonding Technique Base Link - Titanium Gr. 5

EP MT DS Rotating - Bonding Technique - Incollaggio Passivo

EP MV Vite di Ricambio Toronto - Toronto Spare Screw
DMX 1/2 Standard Torx Driver

Adjustable in 5 heights



Analogo Toronto per Laboratorio - Titanio Gr. 5
Laboratory Toronto Analog - Titanium Gr. 5

EP MAL2DS H 10 mm - Universal Shape - Whit screw
EP MAL2DS-V H 10 mm - Universal Shape - Whitout screw

DM 1/2 Standard Hexagonal Driver Ø 1.27



Viti di Ricambio Toronto - Titanio Gr. 5
Toronto Spare Screws - Titanium Gr. 5

EP MV Prosthetic Spare Screw
EP MVL Impression Spare Screw

DMX 1/2 Standard Torx Driver



universal prosthetics

Pilastro a Sfera per Overdenture - Titanio Gr. 5 - PVD TiN

Overdenture Ball Abutment - Titanium Gr. 5 - PVD TiN

- IP 4BA1-W** H 1 mm - **CPS** Standard Gingival Profile - NORMO
- IP 4BA2-W** H 2 mm - **CPS** Standard Gingival Profile - NORMO
- IP 4BA3-W** H 3 mm - **CPS** Standard Gingival Profile - NORMO
- IP 4BA4-W** H 4 mm - **CPS** Standard Gingival Profile - NORMO
- IP 4BA6-W** H 6 mm - **CPS** Standard Gingival Profile - NORMO



DM 1/2 Standard Hexagonal Driver Ø 1.27

OT Equator per Overdenture - Titanio Gr. 5 - PVD TiN

Overdenture OT Equator - Titanium Gr. 5 - PVD TiN

- IP 4EQM1** H 1 mm - Only Abutment - Narrow Gingival Profile
- IP 4EQM2** H 2 mm - Only Abutment - Narrow Gingival Profile
- IP 4EQM3** H 3 mm - Only Abutment - Narrow Gingival Profile
- IP 4EQM4** H 4 mm - Only Abutment - Narrow Gingival Profile
- IP 4EQM5** H 5 mm - Only Abutment - Narrow Gingival Profile
- IP 4EQM6** H 6 mm - Only Abutment - Narrow Gingival Profile



DM EQ Squared Equator Driver

Kit OT Equator per Overdenture - Titanio Gr. 5 - PVD TiN

Overdenture OT Equator Kit - Titanium Gr. 5 - PVD TiN

- IP 4EQ1** H 1 mm - Narrow Gingival Profile
- IP 4EQ2** H 2 mm - Narrow Gingival Profile
- IP 4EQ3** H 3 mm - Narrow Gingival Profile
- IP 4EQ4** H 4 mm - Narrow Gingival Profile
- IP 4EQ5** H 5 mm - Narrow Gingival Profile
- IP 4EQ6** H 6 mm - Narrow Gingival Profile



DM EQ Squared Equator Driver

EasyFlag3D advanced digital impression

Il grande limite nella precisione di un'impronta digitale era legato alla distanza tra gli scanabutment.

La mancanza di un profilo di continuità e la presenza di un tessuto gengivale liscio costringevano ad una costante rielaborazione della posizione da parte del software che spesso generava errori e crash di sistema a discapito dell'accuratezza finale.

EasyFlag3D è un sistema di scansione intraorale di continuità personalizzabile che garantisce velocità di acquisizione ed accuratezza delle immagini STL.

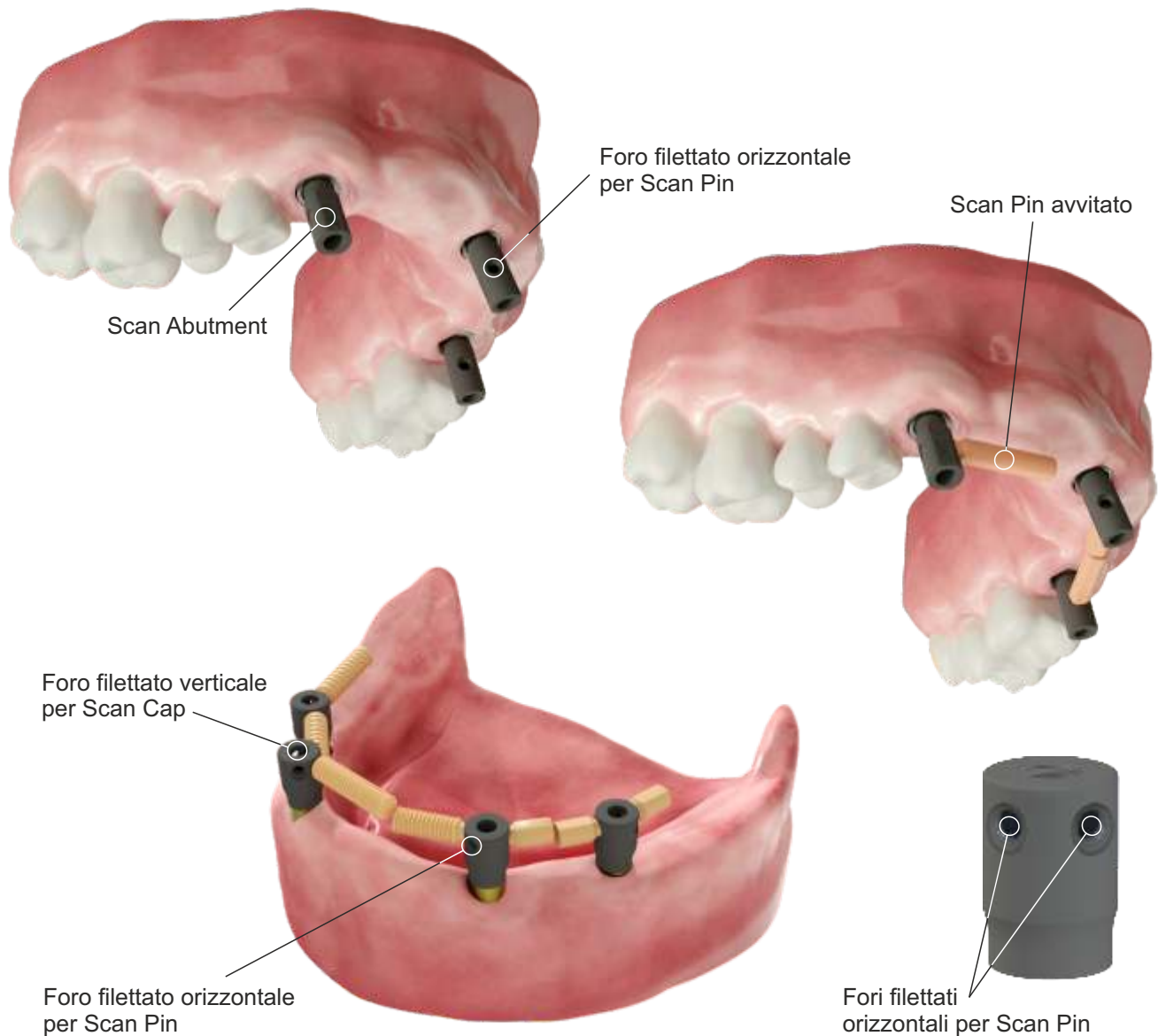

The main limitation in digital impression precision was due to the distance between the scanabutments.

The lack of a continuous profile, combined with the smooth gingival tissue, required the software to continually re-evaluate the position, resulting in frequent errors and system crashes that compromised the final accuracy.

EasyFlag3D is a customizable continuous intraoral scanning system that ensures fast STL image acquisition and accuracy.

EasyFlag3D advanced digital impression

EF3D Scan Abutment - Titanio Gr. 5

Scan Abutment EF3D - Titanium Gr. 5

IP4SADS-EF Scan Abutment EF3D Internal Hexagon CPS

EPMSADS-EF Scan Abutment EF3D Toronto MUA

EPMSAQDS-EF Scan Abutment EF3D UNI-Q-MUA



EF3D Scan Pin Tipe A - Triangolare - PEEK Medicaie

Tipe A Scan Pin EF3D - Triangular Shape - Medical PEEK

SPA6-EF Scan Pin EF3D Type A 6 mm (5 pz)

SPA9-EF Scan Pin EF3D Type A 9 mm (5 pz)

SPA13-EF Scan Pin EF3D Type A 13 mm (5 pz)



EF3D Scan Pin Tipe B - Triangolare - PEEK Medicaie

Tipe B Scan Pin EF3D - Triangular Shape - Medical PEEK

SPB6-EF Scan Pin EF3D Type B 6 mm (5 pz)

SPB9-EF Scan Pin EF3D Type B 9 mm (5 pz)

SPB13-EF Scan Pin EF3D Type B 13 mm (5 pz)



EF3D Scan Pin Tipe C - Triangolare - PEEK Medicaie

Tipe C Scan Pin EF3D - Triangular Shape - Medical PEEK

SPC6-EF Scan Pin EF3D Type C 6 mm (5 pz)

SPC9-EF Scan Pin EF3D Type C 9 mm (5 pz)

SPC13-EF Scan Pin EF3D Type C 13 mm (5 pz)



EF3D Scan Caps - Tappi Filettati per Registrazione Occlusale - PEEK Medicaie

Scan Caps EF3D - Occlusal Registration Screwcaps - Medical PEEK

SCR38-EF Scan Cap EF3D Regular 3.8 mm

SCR60-EF Scan Cap EF3D Regular 6 mm

SCR80-EF Scan Cap EF3D Regular 8 mm





wide prosthetics

20Ncm 



Pilastro di Guarigione - Titanio Gr. 5 - Anodizzato

Healing Abutment - Titanium Gr. 5 - Anodized

IP 5HA3 H 3 mm - Large Gingival Profile

IP 5HA5 H 5 mm - Large Gingival Profile

DM 1/2

Standard Hexagonal Driver Ø 1.27

32Ncm 



Moncone Calcinabile - Acrilico

Castable Abutment - Acrylic

IP 5CA Antirotaion Hex - Large Gingival Profile

IP 5CR Rotating - Large Gingival Profile

IP VITG Vite di Ricambio Gold - Gold Spare Screw

DM 1/2

Standard Hexagonal Driver Ø 1.27

32Ncm 



Moncone in Titanio Dritto - Titanio Gr. 5 - PVD TiN

Straight Titanium Abutments - Titanium Gr. 5 - PVD TiN

IP 5ST3 0° - Large Gingival Profile

IP VITG Vite di Ricambio Gold - Gold Spare Screw

DM 1/2

Standard Hexagonal Driver Ø 1.27

32Ncm 



Monconi in Titanio Angolati - Titanio Gr. 5 - PVD TiN

Angled Titanium Abutments - Titanium Gr. 5 - PVD TiN

IP 5AT15 15° - Large Gingival Profile

IP 5AT25 25° - Large Gingival Profile

IP VITG Vite di Ricambio Gold - Gold Spare Screw

DM 1/2

Standard Hexagonal Driver Ø 1.27

32Ncm 



Moncone Ucla Oro - Base Oro/Platino/Iridio

Ucla Gold Abutment - Gold/Platinum/Iridium Base

IP 5GA Antirotaion Hex - Large Gingival Profile

IP VITG Vite di Ricambio Gold - Gold Spare Screw

DM 1/2

Standard Hexagonal Driver Ø 1.27

wide prosthetics

Moncone UCLA Cobalto Cromo - CoCr

UCLA Abutment Cobalt Chrome - CoCr

IP 4CCA Antirotation Hex - Standard Gingival Profile

IP 4CCA-W Antirotation Hex - **Waisted** Gingival Profile CPS

IP VITG Vite di Ricambio Gold - Gold Spare Screw

DM 1/2 Standard Hexagonal Driver Ø 1.27



Pilastrini Temporanei - Titanio Gr. 5

Temporary Abutments - Titanium Gr. 5

IP 4TA-W Glueing Temporary Abutment - Antirotation Hex

IP 4TR-W Glueing Temporary Abutment - Rotating

IP VITG Vite di Ricambio Gold - Gold Spare Screw

DM 1/2 Standard Hexagonal Driver Ø 1.27



Pilastrini Temporanei da Saldatura - Titanio Gr. 5

Welding Temporary Abutments - Titanium Gr. 5

IP 4TRS Welding Temporary Abutment - Rotating

IP VITG Vite di Ricambio Gold - Gold Spare Screw

DM 1/2 Standard Hexagonal Driver Ø 1.27



Moncone Provvisorio Estetico - PEEK Medica

Aesthetic Temporary Abutment - Medical PEEK

IP 5PA Antirotation Hex - Large Gingival Profile

IP VITG Vite di Ricambio Gold - Gold Spare Screw

DM 1/2 Standard Hexagonal Driver Ø 1.27



Transfer per impronta Pick Up - Titanio Gr. 5

Pick Up Impression Coping - Titanium Gr. 5

IP X50 H 12mm - Internal Hexagon

DM 1/2 Standard Hexagonal Driver



Digital Solutions



Transfer per Impronta Digitale - Titanio Gr. 5 + MS

Scan Abutment - Titanium Gr. 5 + Micro Sandblasting

IP 4SA2 DS Antirotation Hex - **Narrow** Gingival Profile

IP VIT Vite di Ricambio - Spare Screw



Link Flat Digitale per Incollaggio - Titanio Gr. 5

Flat Digital Link for Bonding Technique - Titanium Gr. 5

IP 5TB DS Flat Titanium Link - Antirotation Hex - Ø4mm

IP 5TBR DS Flat Titanium Link - Rotating - Ø4mm

IP VITG Vite di Ricambio Gold - Gold Spare Screw

DM 1/2 [Standard Hexagonal Driver Ø 1.27](#)



Analogo Digitale per Laboratorio - Titanio Gr. 5 - Anodizzato

Laboratory Digital Analog - Titanium Gr. 5 - Anodized

IP 5AL2DS H 12 mm - Universal Shape



Pilastro a Sfera per Overdenture - Titanio Gr. 5 - PVD TiN

Overdenture Ball Abutment - Titanium Gr. 5 - PVD TiN

IP 4BA1-W H 1 mm - **CPS** Standard Gingival Profile - NORMO

IP 4BA2-W H 2 mm - **CPS** Standard Gingival Profile - NORMO

IP 4BA3-W H 3 mm - **CPS** Standard Gingival Profile - NORMO

IP 4BA4-W H 4 mm - **CPS** Standard Gingival Profile - NORMO

IP 4BA6-W H 6 mm - **CPS** Standard Gingival Profile - NORMO

DM 1/2 [Standard Hexagonal Driver](#)



Kit OT Equator per Overdenture - Titanio Gr. 5 - PVD TiN

Overdenture OT Equator Kit - Titanium Gr. 5 - PVD TiN

IP 4EQ1 H 1 mm - Narrow Gingival Profile

IP 4EQ2 H 2 mm - Narrow Gingival Profile

IP 4EQ3 H 3 mm - Narrow Gingival Profile

IP 4EQ4 H 4 mm - Narrow Gingival Profile

IP 4EQ5 H 5 mm - Narrow Gingival Profile

DMEQ [Squared Equator Driver](#)

toronto universal prosthetics

Pilastro Toronto Dritto - Titanio Gr. 5

Toronto Straight Abutment - Titanium Gr. 5

IP MS1-W H 1 mm - Standard Gingival Profile

IP MS2-W H 2 mm - Standard Gingival Profile

IP MS3-W H 3 mm - Standard Gingival Profile

DCDM Toronto Straight Abutment Driver



Pilastro Toronto Angolato 17° - Titanio Gr. 5

17° Toronto Angled Abutment - Titanium Gr. 5

IP MA172-W 17° - H 2 mm - Standard Gingival Profile

IP MA173-W 17° - H 3 mm - Standard Gingival Profile

IP VITMA Vite di Ricambio Toronto - Toronto Spare Screw

DMX 1/2 Standard Torx Driver



Pilastro Toronto Angolato 30° - Titanio Gr. 5

30° Toronto Angled Abutment - Titanium Gr. 5

IP MA303-W 30° - H 3 mm - Standard Gingival Profile

IP MA304-W 30° - H 4 mm - Standard Gingival Profile

IP MA305-W 30° - H 5 mm - Standard Gingival Profile

IP VITMA Vite di Ricambio Toronto - Toronto Spare Screw

DMX 1/2 Standard Torx Driver



Pilastro Temporaneo Toronto - Titanio Gr. 5

Toronto Temporary Abutment - Titanium Gr. 5

EP MT Rotating - Bonding Technique - Incollaggio Passivo

EP MTS Rotating - Welding Technique - Saldatura Intraorale

EP MV Vite di Ricambio Toronto - Toronto Spare Screw

DMX 1/2 Standard Torx Driver



Pilastrini di Guarigione e Transfer Toronto

Toronto Healing Abutment and Impression Coping

EP MI Rotating - Standard Gingival Profile

EP MHA H 4 mm - Standard Gingival Profile

EP MHA6 H 6 mm - Large Gingival Profile

DMX 1/2 Standard Torx Driver





INTERNAL HEXAGON
HYBRID SOFT TISSUE LEVEL

ONETIME
TAPERED SHAPE



IK HTML

Onetime Surgical Protocol

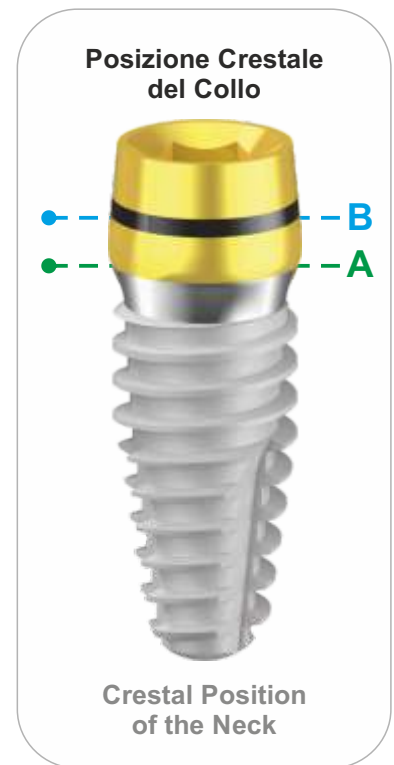
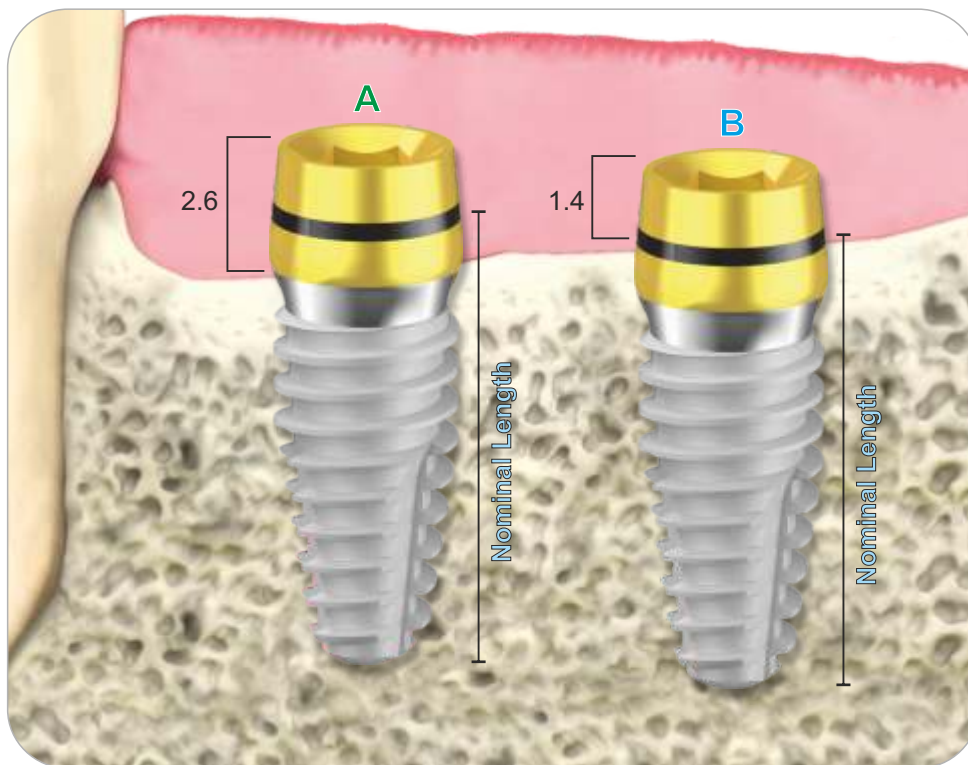

Preparazione del tunnel implantare con e senza affondamento parziale del collo

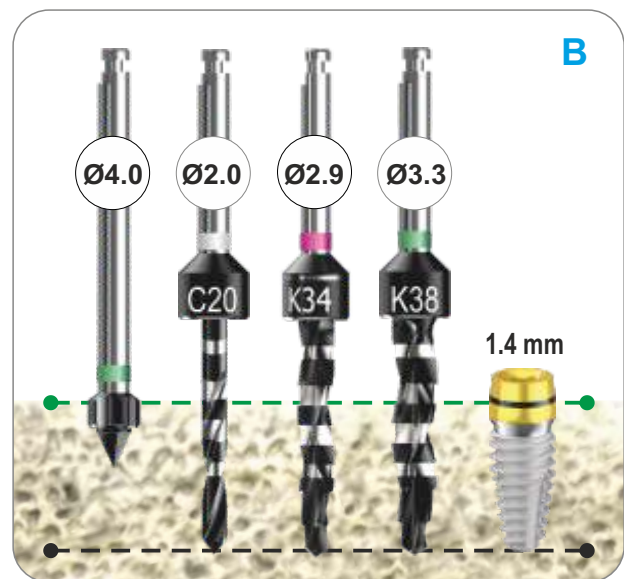
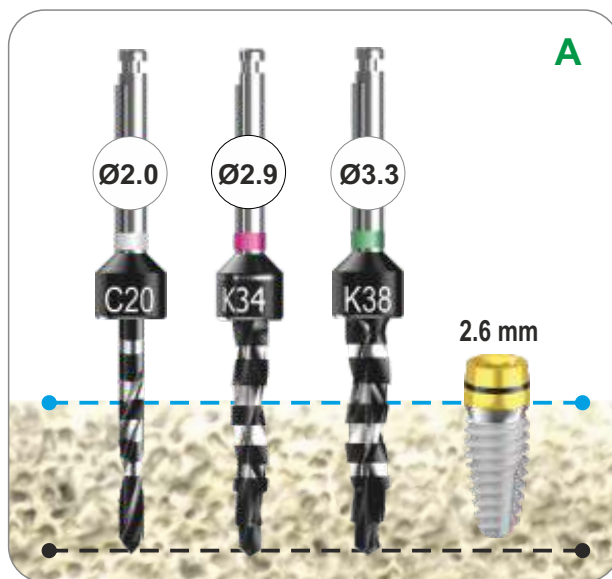

LINEA IMPIANTI ONETIME - Caratterizzata dall'innovativa geometria ibrida del collo che prevede **2 differenti approcci chirurgici** e **3 differenti sviluppi protesici**, in funzione delle necessità cliniche. La preparazione del tunnel implantare, **emergente** o **semi-sommerso**, determina la posizione transgingivale del collo per meglio adattarsi alle condizioni dei tessuti perimplantari. La protesizzazione su **3 differenti livelli** si adatta alle necessità estetiche, biologiche e meccaniche.



ONETIME IMPLANTS LINE - Characterized by the innovative hybrid geometry of the neck which uses **2 different surgical approaches** and **3 different prosthetic developments**, depending on clinical needs. The preparation of the implant tunnel, **emerging** or **semi-submerged**, determines the neck transgingival position for a better adapt to the peri-implant tissues conditions. The prosthesis on **3 different levels** adapts to aesthetic, biological and mechanical needs.

Onetime Prosthetic Protocol

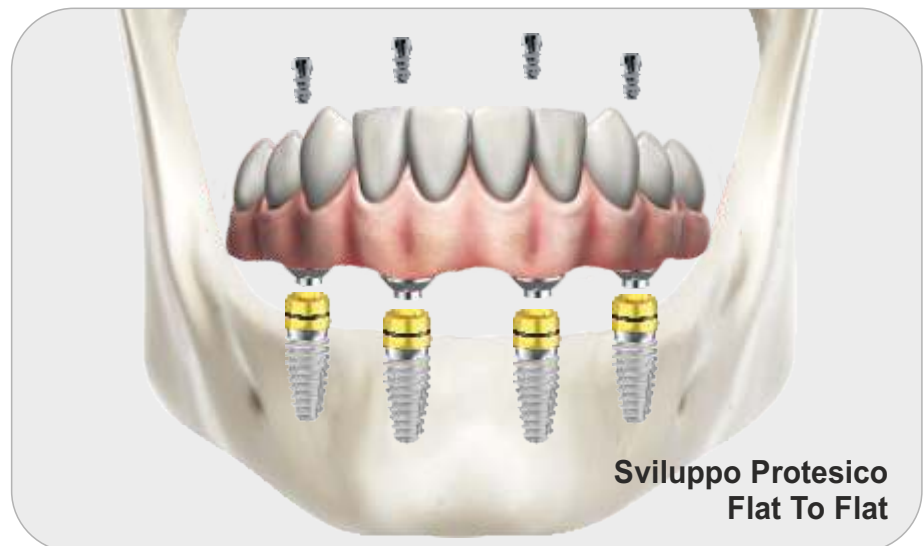

COMPONENTISTICA ONETIME - Caratterizzata da 2 differenti sviluppi protesici in funzione delle necessità cliniche (FLAT e OT MORSE) ma con l'aggiunta di una variante di emergenza (EMERGENCY).

Le componenti **FLAT** sono indicate in tutti i casi di protesi avvitata solidarizzata, in presenza di tragitti mucosi particolarmente spessi e nella post estrattiva quando l'impianto risulta particolarmente affondato.

Le componenti **OT MORSE** sono indicate negli elementi singoli o piccoli ponti di 2 elementi tra impianti paralleli, in presenza di tragitti mucosi sottili, nei quadranti anteriori quando si richiede un'estetica delle paraboliche gengivali e quando si ricerca il comportamento stabile dei tessuti molli e duri a lungo termine.



ONETIME COMPONENTS - Characterized by 2 different prosthetic developments based on clinical needs (FLAT and OT MORSE) but with the addition of one emergency variant (EMERGENCY).

The **FLAT** components are indicated in all screwed prosthesis cases, in the presence of particularly thick mucosal tracts and in post-extraction surgery when the implant is particularly deep.

The **OT MORSE** components are indicated in the single elements, in presence of thin mucosal tracts, in the anterior quadrants when the aesthetics gingival parabolas are required and when stable long-term behavior of the soft and hard tissues are wanted.

IK 34 ONETIME

**MAX
70 Ncm**

TAPERED SHAPE
Internal Hexagon

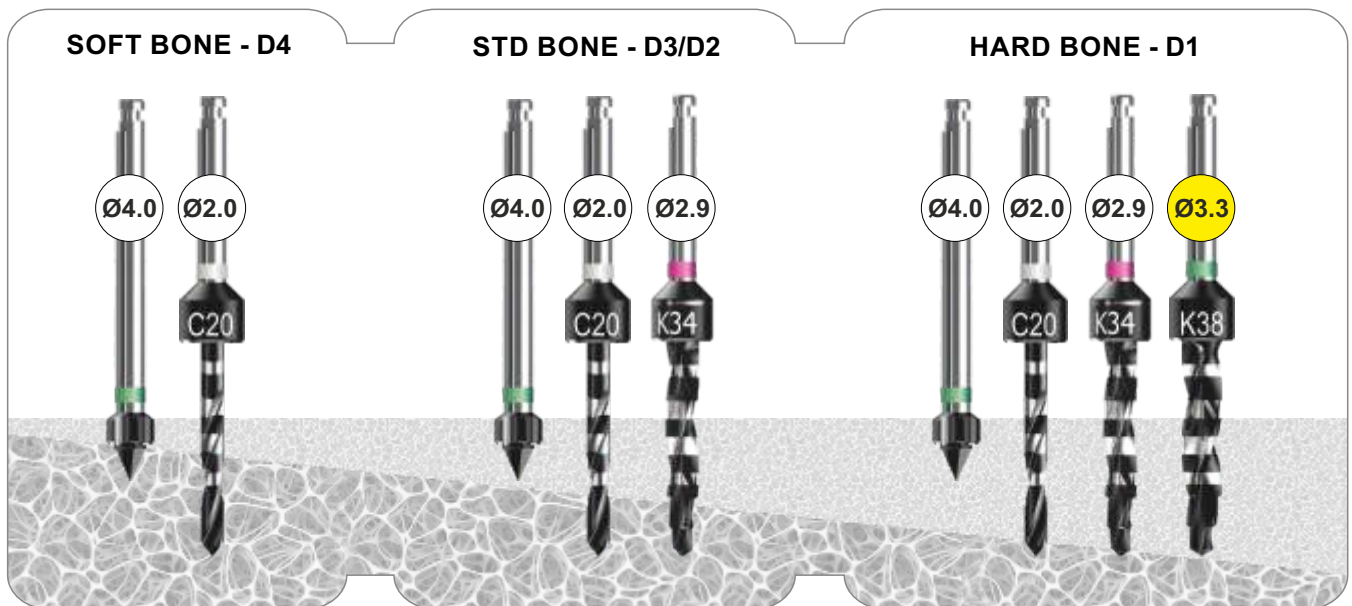
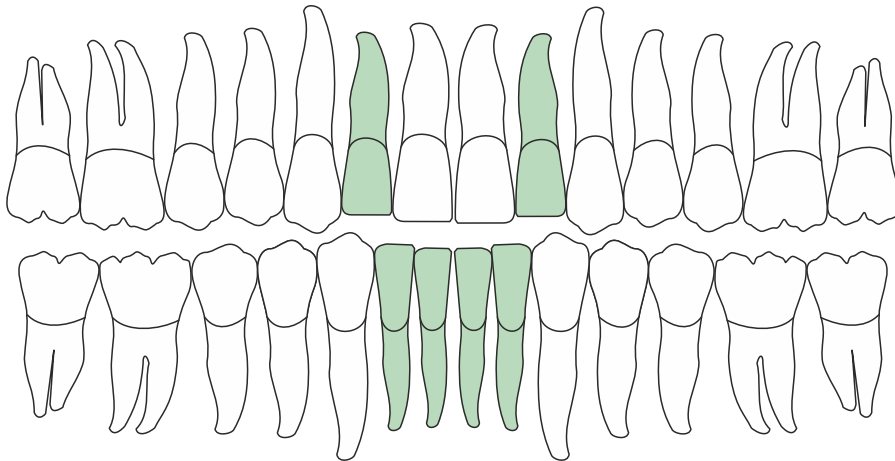
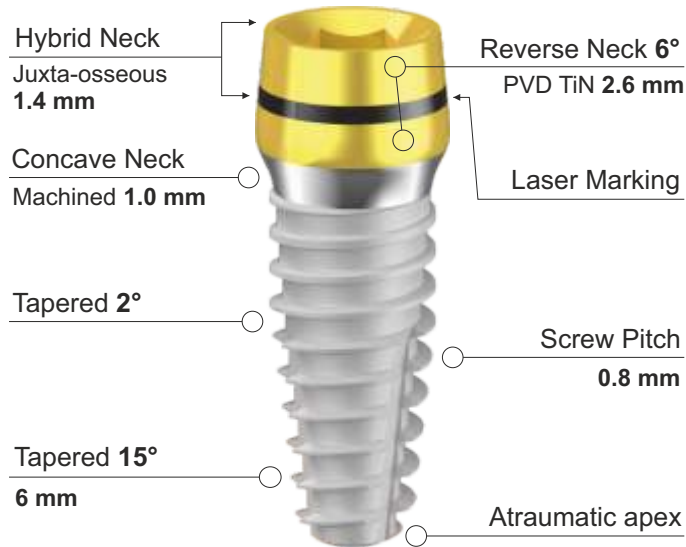

Velocità di rotazione frese consigliata 500 - 800 rpm

Recommended milling burs rotation speed 500 - 800 rpm

IK 38 ONETIME



TAPERED SHAPE
Internal Hexagon

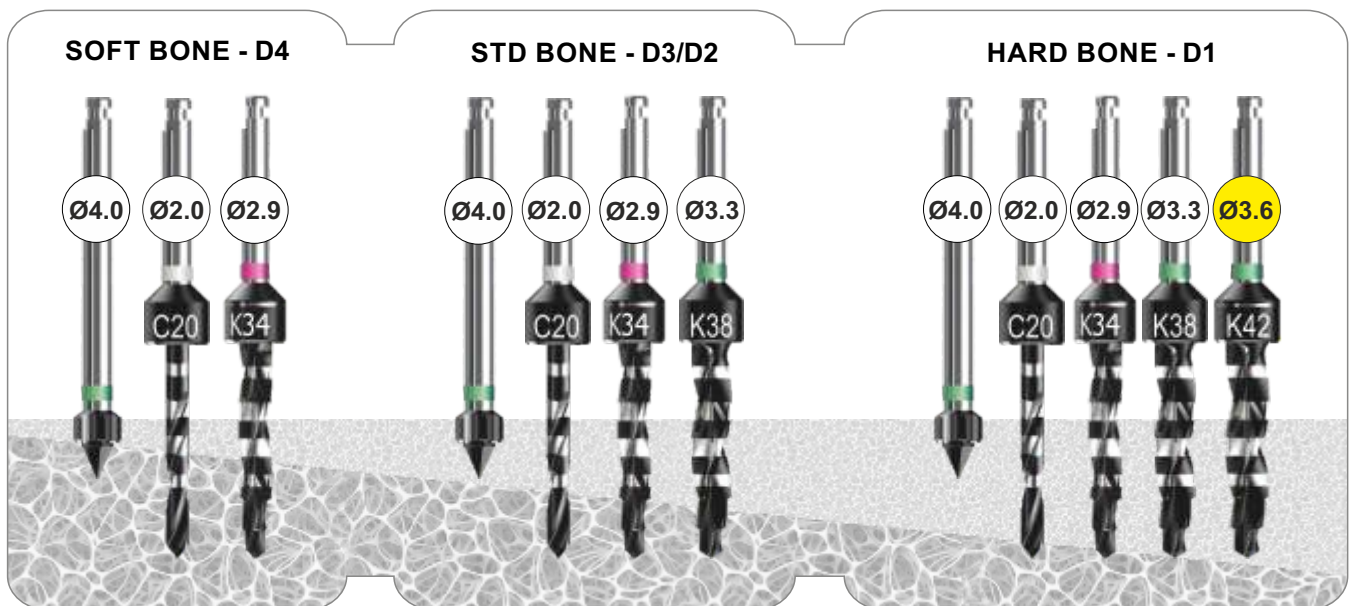
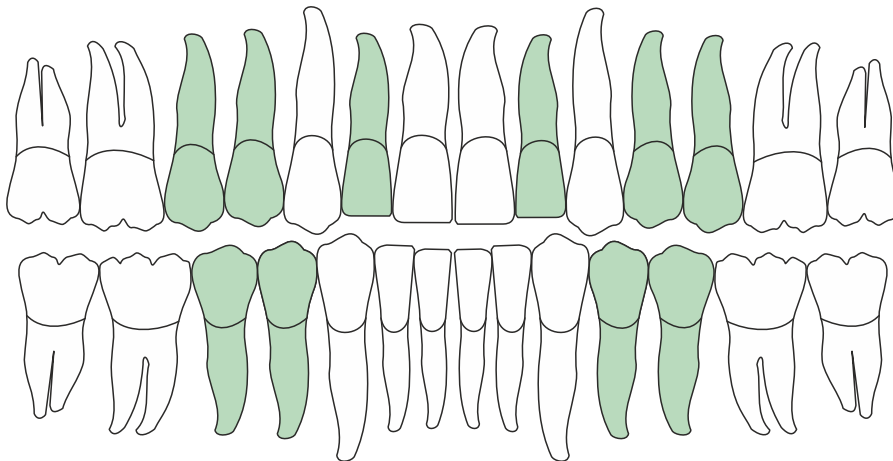
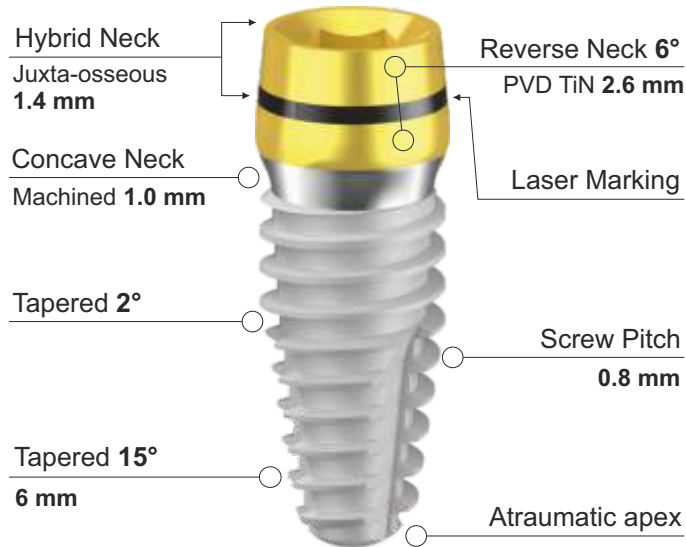

Velocità di rotazione frese consigliata 500 - 800 rpm

Recommended milling burs rotation speed 500 - 800 rpm

IK 46 ONETIME

MAX
70 Ncm

TAPERED SHAPE
Internal Hexagon

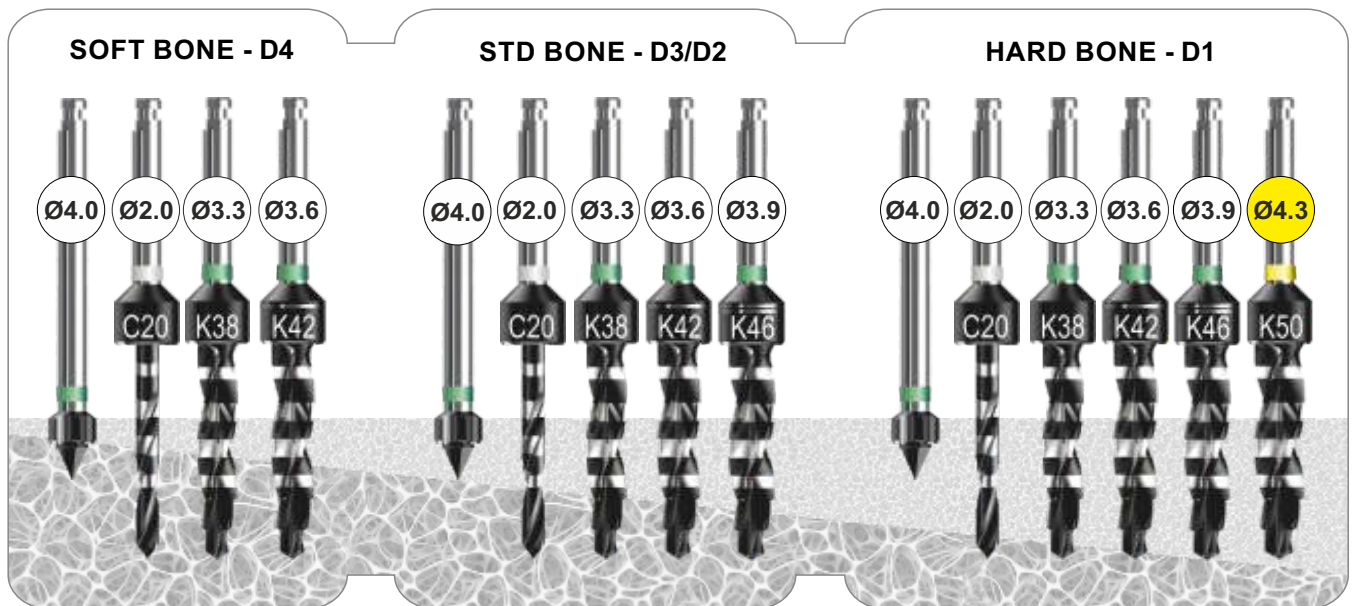
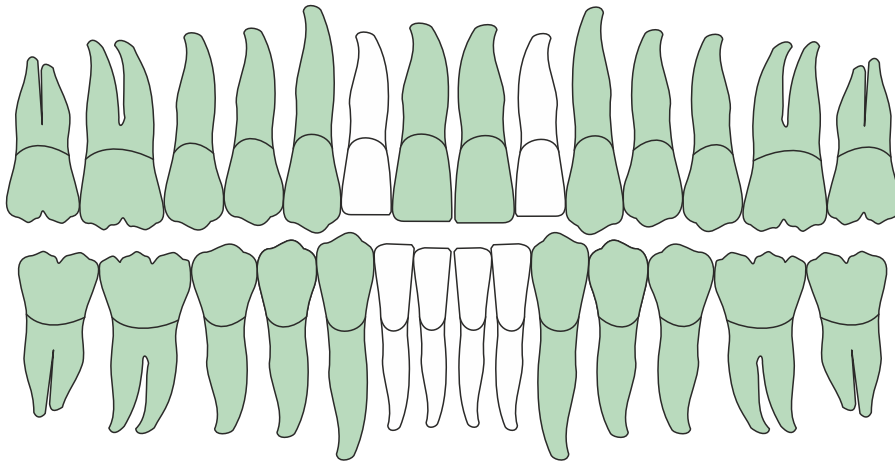
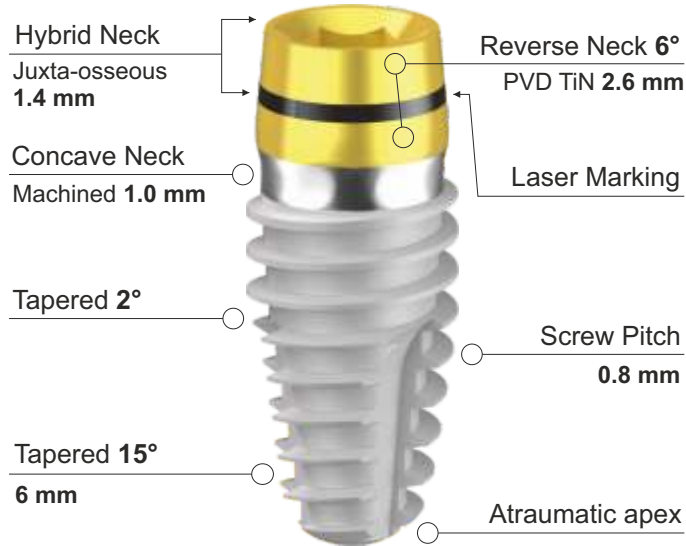

Velocità di rotazione frese consigliata 500 - 800 rpm

Recommended milling burs rotation speed 500 - 800 rpm

3.4 Hybrid Soft Tissue Level Half Treatment - Mounterless



CODE	IMPLANT	LENGTH	THREAD	NECK	APEX
IK 3407 HTML	Ø 3.4	7.0 mm	4.8 mm	Ø 4.1	Ø 1.8
IK 3408 HTML	Ø 3.4	8.5 mm	6.3 mm	Ø 4.1	Ø 1.8
IK 3410 HTML	Ø 3.4	10.0 mm	7.8 mm	Ø 4.1	Ø 1.8
IK 3411 HTML	Ø 3.4	11.5 mm	9.3 mm	Ø 4.1	Ø 1.8
IK 3413 HTML	Ø 3.4	13.0 mm	10.8 mm	Ø 4.1	Ø 1.8
IK 3415 HTML	Ø 3.4	15 mm	12.8 mm	Ø 4.1	Ø 1.8

3.8 Hybrid Soft Tissue Level Half Treatment - Mounterless



CODE	IMPLANT	LENGTH	THREAD	NECK	APEX
IK 3807 HTML	Ø 3.8	7.0 mm	4.8 mm	Ø 4.1	Ø 1.9
IK 3808 HTML	Ø 3.8	8.5 mm	6.3 mm	Ø 4.1	Ø 1.9
IK 3810 HTML	Ø 3.8	10.0 mm	7.8 mm	Ø 4.1	Ø 1.9
IK 3811 HTML	Ø 3.8	11.5 mm	9.3 mm	Ø 4.1	Ø 1.9
IK 3813 HTML	Ø 3.8	13.0 mm	10.8 mm	Ø 4.1	Ø 1.9
IK 3815 HTML	Ø 3.8	15 mm	12.8 mm	Ø 4.1	Ø 1.9

4.6 Hybrid Soft Tissue Level Half Treatment - Mounterless



CODE	IMPLANT	LENGTH	THREAD	NECK	APEX
IK 4607 HTML	Ø 4.6	7.0 mm	4.8 mm	Ø 4.1	Ø 2.5
IK 4608 HTML	Ø 4.6	8.5 mm	6.3 mm	Ø 4.1	Ø 2.5
IK 4610 HTML	Ø 4.6	10.0 mm	7.8 mm	Ø 4.1	Ø 2.5
IK 4611 HTML	Ø 4.6	11.5 mm	9.3 mm	Ø 4.1	Ø 2.5
IK 4613 HTML	Ø 4.6	13.0 mm	10.8 mm	Ø 4.1	Ø 2.5
IK 4615 HTML	Ø 4.6	15 mm	12.8 mm	Ø 4.1	Ø 2.5



INTERNAL HEXAGON OT MORSE CONNECTION

ONETIME OT MORSE PROSTHETICS



ONETIME OT Morse prosthetics

15Ncm 



Pilastro di Guarigione OT Morse - Titanio Gr. 5 - Anodizzato
TG Morse Healing Abutment - Titanium Gr. 5 - Anodized

IP 5HA2 OT H 2 mm - Morse Profile Ø 5.0
IP 5HA4 OT H 4 mm - Morse Profile Ø 5.0
IP 5HA6 OT H 6 mm - Morse Profile Ø 5.0

DM 1/2 Standard Hexagonal Driver

15Ncm 



Pilastro di Guarigione OT Morse - Titanio Gr. 5 - Anodizzato
TG Morse Healing Abutment - Titanium Gr. 5 - Anodized

IP 6HA2 OT H 2 mm - Morse Profile Ø 6.0
IP 6HA4 OT H 4 mm - Morse Profile Ø 6.0
IP 6HA6 OT H 6 mm - Morse Profile Ø 6.0

DM 1/2 Standard Hexagonal Driver

15Ncm 



Transfer per impronta Pick Up TG Morse - Titanio Gr. 5
TG Morse Pick Up Impression Coping - Titanium Gr. 5

IP X50 OT Morse Profile Ø 5.0 - Internal Hexagon
IP X60 OT Morse Profile Ø 6.0 - Internal Hexagon

DM 1/2 Standard Hexagonal Driver Ø 1.27



Analogo per Laboratorio OT Morse - Titanio Gr. 5
OT Morse Laboratory Analog - Titanium Gr. 5

IP 4ALDS OT H 10 mm - Universal Shape

DM 1/2 Standard Hexagonal Driver Ø 1.27

ONETIME OT Morse prosthetics

Moncone Titanio Diritto OT Flat - Titanio Gr. 5 - PVD TiN

OT Flat Straight Titanium Abutment - Ti Gr. 5 - PVD TiN

IP 4ST1 OT 0° - Flat 5mm Straight Profile
IP 4ST2 OT 0° - Flat 8mm Straight Profile

IP VITG Vite di Ricambio Gold - Gold Spare Screw
DM 1/2 Standard Hexagonal Driver Ø 1.27



Moncone Calcinabile TG Morse - Acrilico

TG Morse Castable Abutment - Acrylic

IP 50CA OT Morse Profile Ø 5.0 - Internal Hexagon
IP 50CR OT Morse Profile Ø 5.0 - Rotating
IP 60CA OT Morse Profile Ø 6.0 - Internal Hexagon
IP 60CR OT Morse Profile Ø 6.0 - Rotating

DM 1/2 Standard Hexagonal Driver Ø 1.27



Moncone UCLA Cobalto Cromo TG Morse - CoCr

TG Morse UCLA Abutment Cobalt Chrome - CoCr

IP 5CCA OT Antirotation Hex - Morse Profile Ø 5.0
IP 5CCR OT Rotating Hex - Morse Profile Ø 5.0

DM 1/2 Standard Hexagonal Driver Ø 1.27



Link Base per Incollaggio - Titanio Gr. 5

Bonding Technique Base Link - Titanium Gr. 5

IP 5TBDS OT Antirotation Hex - ● Morse Profile Ø 5.0
IP 5TBRDS OT Rotating - ● Morse Profile Ø 5.0

IP 6TBDS OT Antirotation Hex - ● Morse Profile Ø 6.0
IP 6TBRDS OT Rotating - ● Morse Profile Ø 6.0

IP VITG Vite di Ricambio Gold - Gold Spare Screw
DM 1/2 Standard Hexagonal Driver Ø 1.27

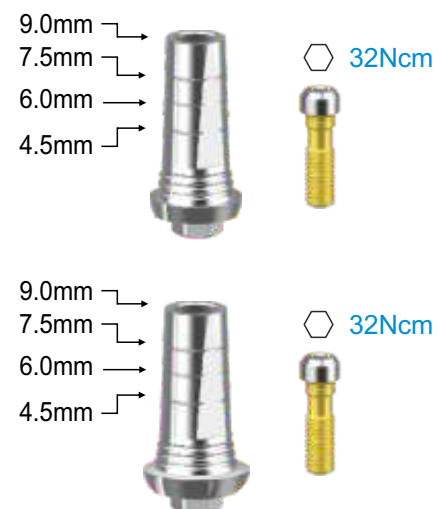



MORSE CONNECTION

INTERNAL HEXAGON

NARROW 2.9
TAPERED SHAPE



KN

KN 29



TAPERED SHAPE Morse Connection 4°

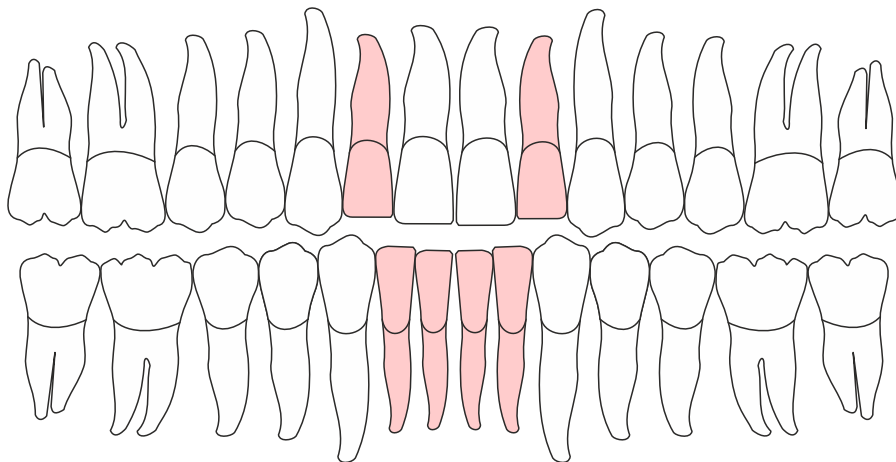
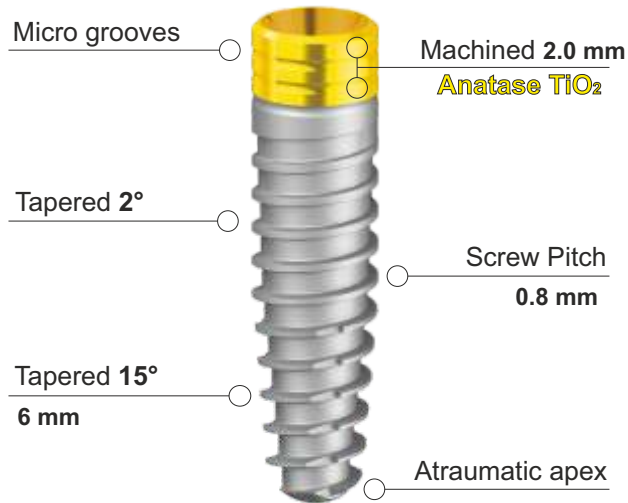

SOFT BONE - D4



STD BONE - D3/D2



HARD BONE - D1

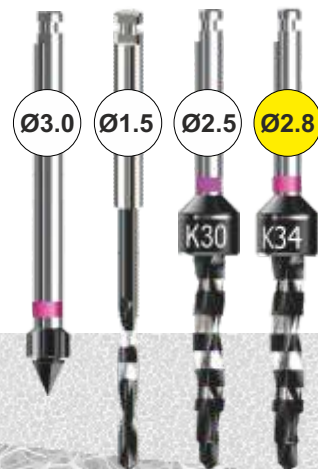

Velocità di rotazione frese consigliata 500 - 800 rpm

Recommended milling burs rotation speed 500 - 800 rpm

2.9 Half Treatment **Anatase TiO₂** - Mounterless



CODE	IMPLANT	LENGTH	NECK	APEX
IK 2908	Ø 2.9	8.5 mm	Ø 3.0	Ø 1.5
IK 2910	Ø 2.9	10 mm	Ø 3.0	Ø 1.5
IK 2911	Ø 2.9	11.5 mm	Ø 3.0	Ø 1.5
IK 2913	Ø 2.9	13 mm	Ø 3.0	Ø 1.5



DMRP120S Hexagonal Manual Driver 1.20 - Short



DMRP120L Hexagonal Manual Driver 1.20 - Long



Avvitatori per impianto - Implant Drivers

ACK 2S Contra-angle Implant Driver - Short



ACK 2L Contra-angle Implant Driver - Long



PCK 2S Ratchet Implant Driver - Short



PCK 2L Ratchet Implant Driver - Long



Accessori - Implant Tools

EKN Abutment Extractor



CRDP2 Cricchetto
Dinamometrico



Dinamometrico Protesico 0/70 Ncm - Torque Control

K-Narrow prosthetics

25Ncm 



Pilastro di Guarigione - Titanio Gr. 5

Healing Abutment - Titanium Gr. 5

IP 2HA2 H 2 mm - Narrow Gingival Profile

IP 2HA3 H 3 mm - Narrow Gingival Profile

IP 2HA5 H 5 mm - Narrow Gingival Profile

IP 2HA7 H 7 mm - Narrow Gingival Profile

DMRP120S [Narrow Hexagonal Driver Ø 1.20](#)

25Ncm 



Transfer da Impronta - Titanio Gr. 5

Impression Coping Abutment - Titanium Gr. 5

IP 2IA Impression Coping - Pick Up Technique

IP 2VITIA Vite Lunga di Ricambio - Long Spare Screw

DMRP120S [Narrow Hexagonal Driver Ø 1.20](#)

Analogo da Laboratorio - Titanio Gr. 5

Implant Analog - Titanium Gr. 5



IP 2AL Laboratory Analog

DMRP120S [Narrow Hexagonal Driver Ø 1.20](#)

25Ncm 

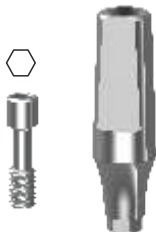

Moncone Titanio Diritto - Titanio Gr. 5

Straight Titanium Abutment - Titanium Gr. 5

IP 2ST2 H 2 mm - Narrow Gingival Profile

IP 2ST3 H 3 mm - Narrow Gingival Profile

IP 2ST5 H 5 mm - Narrow Gingival Profile

IP 2VIT Vite di Ricambio - Spare Screw

DMRP120S [Narrow Hexagonal Driver Ø 1.20](#)

25Ncm 



Moncone Titanio Angolato - Titanio Gr. 5

Angled Titanium Abutment - Titanium Gr. 5

IP 2AT152 15° - H 2 mm - Narrow Gingival Profile

IP 2AT153 15° - H 3 mm - Narrow Gingival Profile

IP 2AT252 25° - H 2 mm - Narrow Gingival Profile

IP 2AT253 25° - H 3 mm - Narrow Gingival Profile

DMRP120S [Narrow Hexagonal Driver Ø 1.20](#)

K-Narrow prosthetics

Moncone UCLA Cobalto Cromo - CoCr

UCLA Abutment Cobalt Chrome - CoCr

IP 2CCA Antirotation Hex - Narrow Gingival Profile

IP 2CCR Rotating Hex - Narrow Gingival Profile

IP 2VIT Vite di Ricambio - Spare Screw

DMRP120S Narrow Hexagonal Driver Ø 1.20



Link Base per Incollaggio - Titanio Gr. 5

Bonding Technique Base Link - Titanium Gr. 5

IP 2TB1 DS Gingival Profile **H 1mm** - Antirotazione

IP 2TBR1 DS Gingival Profile **H 1mm** - Rotante

IP 2TB2 DS Gingival Profile **H 2mm** - Antirotazione

IP 2TBR2 DS Gingival Profile **H 2mm** - Rotante

IP 2TB3 DS Gingival Profile **H 3mm** - Antirotazione

IP 2TBR3 DS Gingival Profile **H 3mm** - Rotante

IP 2VIT Vite di Ricambio - Spare Screw

DMRP120S Narrow Hexagonal Driver Ø 1.20



Analogo e Transfer Digitali - Titanio Gr. 5

Digital Analog and Scan Abutment - Titanium Gr. 5

IP 2AL DS Digital Analog with Screw

IP 2SA DS Digital Scan Abutment

DMRP120S Narrow Hexagonal Driver Ø 1.20



Kit Pilastro Equator per Overdenture - Titanio Gr. 5 - PVD TiN

Overdenture Equator Abutment Kit - Titanium Gr. 5 - PVD TiN

IP 2EQ1 H 1 mm - Narrow Gingival Profile

IP 2EQ2 H 2 mm - Narrow Gingival Profile

IP 2EQ3 H 3 mm - Narrow Gingival Profile

IP 2EQ4 H 4 mm - Narrow Gingival Profile

IP 2EQ5 H 5 mm - Narrow Gingival Profile

DMEQ Squared Equator Driver





INTERNAL HEXAGON NARROW CONNECTION

NARROW
CYLINDRICAL
SHAPE



IC

IC 30

CYLINDRICAL SHAPE Internal Hexagon



!
AVVITAMENTO
SOLO CON
MOUNTER
SCREWING
ONLY WITH
MOUNTER

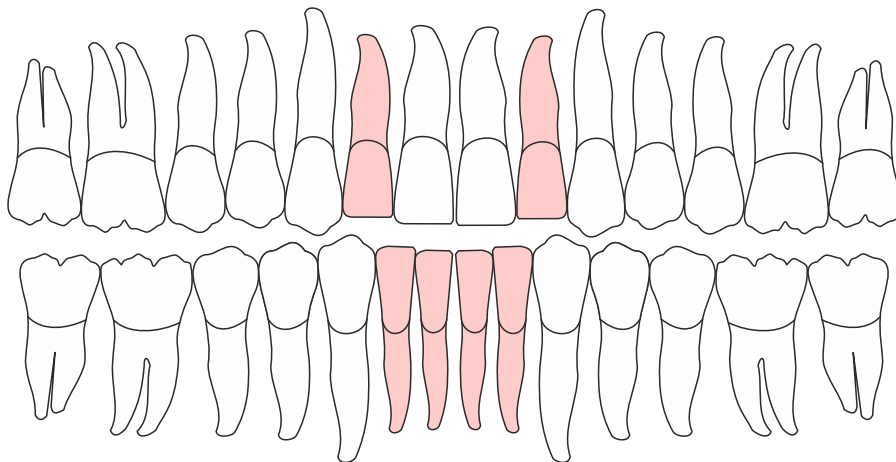
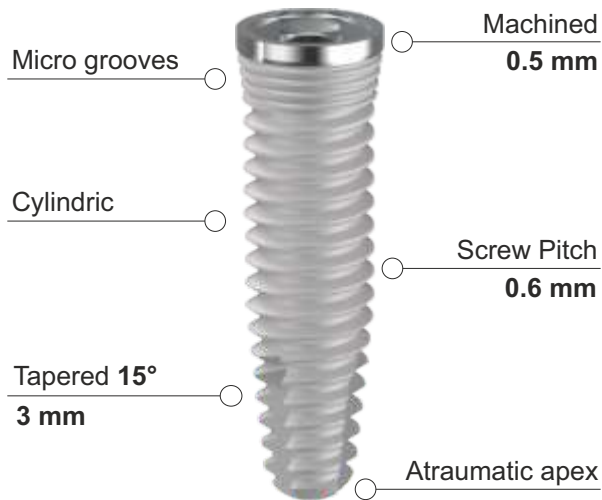

SOFT BONE - D4



STD BONE - D3/D2



HARD BONE - D1



Velocità di rotazione frese consigliata 500 - 800 rpm

Recommended milling burs rotation speed 500 - 800 rpm

IC 34

CYLINDRICAL SHAPE Internal Hexagon



!
AVVITAMENTO
SOLO CON
MOUNTER
SCREWING
ONLY WITH
MOUNTER

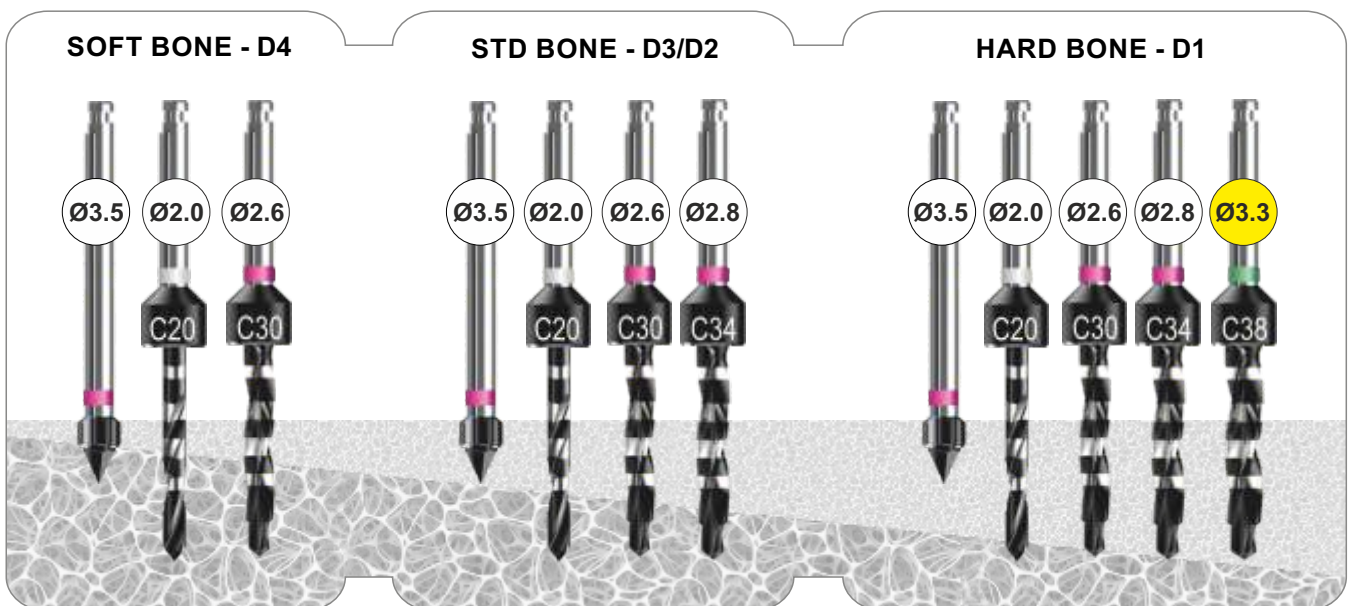
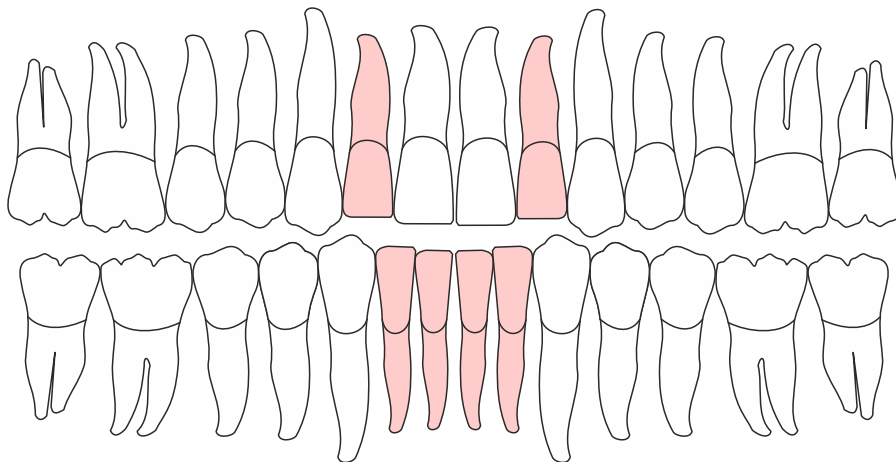
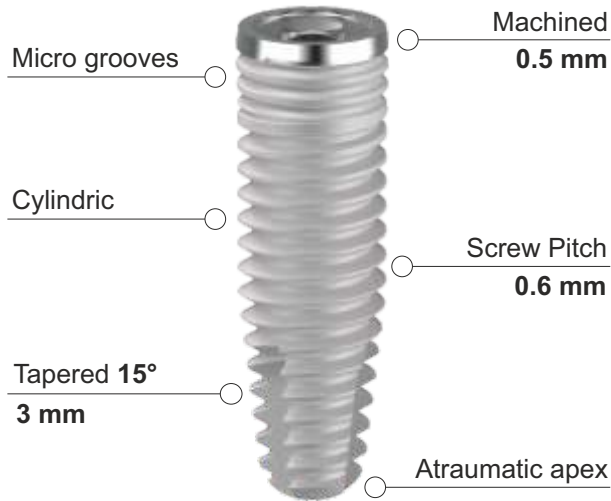

Velocità di rotazione frese consigliata 500 - 800 rpm

Recommended milling burs rotation speed 500 - 800 rpm

3.0 Full Treatment - With Moulder



CODE	IMPLANT	LENGTH	PLATFORM	APEX
IC 3008	Ø 3.0	8.5 mm	Ø 3.5	Ø 2.2
IC 3010	Ø 3.0	10 mm	Ø 3.5	Ø 2.2
IC 3011	Ø 3.0	11.5 mm	Ø 3.5	Ø 2.2
IC 3013	Ø 3.0	13 mm	Ø 3.5	Ø 2.2
IC 3015	Ø 3.0	15 mm	Ø 3.5	Ø 2.2

3.4 Full Treatment - With Moulder



CODE	IMPLANT	LENGTH	PLATFORM	APEX
IC 3408	Ø 3.4	8.5 mm	Ø 3.5	Ø 2.5
IC 3410	Ø 3.4	10 mm	Ø 3.5	Ø 2.5
IC 3411	Ø 3.4	11.5 mm	Ø 3.5	Ø 2.5
IC 3413	Ø 3.4	13 mm	Ø 3.5	Ø 2.5



INTERNAL HEXAGON NARROW CONNECTION

NARROW PROSTHETICS



narrow prosthetics

20Ncm 



Pilastro di Guarigione - Titanio Gr. 5 - Anodizzato
Healing Abutment - Titanium Gr. 5 - Anodized

IP 3HA3 H 3 mm - Small Gingival Profile

IP 3HA5 H 5 mm - Small Gingival Profile

DM 1/2 [Standard Hexagonal Driver](#)

Analogo per Laboratorio - Titanio Gr. 5 - Anodizzato
Laboratory Analog - Titanium Gr. 5 - Anodized



IP 3AL2DS-V H 12 mm - Universal Shape

32Ncm 



Moncone Calcinabile - Acrilico
Castable Abutment - Acrylic

IP 3CA Antirotaion Hex - Small Gingival Profile

IP 3CR Rotating - Small Gingival Profile

IP VITG Vite di Ricambio Gold - Gold Spare Screw

DM 1/2 [Standard Hexagonal Driver](#)

32Ncm 



Moncone Titanio Dritto - Titanio Gr. 5 - PVD TiN

Straight Titanium Abutment - Titanium Gr. 5 - PVD TiN

IP 3ST2 0° - Straight - Small Gingival Profile

IP VITG Vite di Ricambio Gold - Gold Spare Screw

DM 1/2 [Standard Hexagonal Driver](#)

32Ncm 



Moncone Titanio Angolato - Titanio Gr. 5 - PVD TiN

Angled Titanium Abutment - Titanium Gr. 5 - PVD TiN

IP 3AT15 15° - Angled - Small Gingival Profile

IP 3AT25 25° - Angled - Small Gingival Profile

IP VITG Vite di Ricambio Gold - Gold Spare Screw

DM 1/2 [Standard Hexagonal Driver](#)

narrow prosthetics

Moncone Provvisorio Estetico - PEEK Mediale

Aesthetic Temporary Abutment - Medical PEEK

IP 3PA Antirotation Hex - Small Gingival Profile

IP VITG Vite di Ricambio Gold - Gold Spare Screw
DM 1/2 Standard Hexagonal Driver



Pilastro Temporaneo - Titanio Gr. 5

Temporary Abutment - Titanium Gr. 5

IP 3TA Antirotation Hex - Small Gingival Profile

IP 3TR Rotating - Small Gingival Profile

IP VITG Vite di Ricambio Gold - Gold Spare Screw
DM 1/2 Standard Hexagonal Driver



Pilastro a Sfera per Overdenture - Titanio Gr. 5 - PVD TiN

Overdenture Ball Abutment - Titanium Gr. 5 - PVD TiN

IP 3BA1 H 1 mm - Small Gingival Profile - NORMO

IP 3BA2 H 2 mm - Small Gingival Profile - NORMO

IP 3BA4 H 4 mm - Small Gingival Profile - NORMO

DM 1/2 Standard Hexagonal Driver



Kit Pilastro Equator per Overdenture - Titanio Gr. 5 - PVD TiN

Overdenture Equator Abutment Kit - Titanium Gr. 5 - PVD TiN

IP 3EQ1 H 1 mm - Small Gingival Profile

IP 3EQ2 H 2 mm - Small Gingival Profile

IP 3EQ3 H 3 mm - Small Gingival Profile

IP 3EQ4 H 4 mm - Small Gingival Profile

IP 3EQ5 H 5 mm - Small Gingival Profile

IP 3EQ6 H 6 mm - Small Gingival Profile



DMEQ Squared Equator Driver

Transfer per impronta Pick Up - Titanio Gr. 5

Pick Up Impression Coping - Titanium Gr. 5



IP X35 H 12mm - Internal Hexagon

IP VIT20 Vite di Ricambio Gold - Gold Spare Screw
DM 1/2 Standard Hexagonal Driver



toronto narrow prosthetics



Pilastro Toronto 4 Diritto - Titanio Gr. 5
Toronto 4 Straight Abutment - Titanium Gr. 5

32Ncm  

IP 3MS2 H 2 mm - Small Gingival Profile
IP 3MS3 H 3 mm - Small Gingival Profile

DCDM [Standard Torx Driver](#)



Pilastro Toronto 4 Angolato - Titanio Gr. 5
Toronto 4 Angled Abutment - Titanium Gr. 5

32Ncm  

IP 3MA173 17° - H 3 mm - Small Gingival Profile
IP 3MA304 30° - H 4 mm - Small Gingival Profile

IP VITMA Vite di Ricambio Toronto - Toronto Spare Screw
DMX 1/2 [Standard Torx Driver](#)



Pilastro Temporaneo Toronto - Titanio Gr. 5
Toronto Temporary Abutment - Titanium Gr. 5

15Ncm  

EP MT Rotating - Bonding Technique - Incollaggio Passivo
EP MTS Rotating - Welding Technique - Saldatura Intraorale

EP MV Vite di Ricambio Toronto - Toronto Spare Screw
DMX 1/2 [Standard Torx Driver](#)



Pilastro Calcinabile Toronto - Acrilico
Toronto Castable Abutment - Acrylic

15Ncm  

EP MC Rotating Castable Abutment - Moncone Calcinabile

EP MV Vite di Ricambio Toronto - Toronto Spare Screw
DMX 1/2 [Standard Torx Driver](#)

Pilastro di Guarigione Toronto
Toronto Healing Abutment

15Ncm  

EP MHA H 4 mm - Standard Gingival Profile Titanium Gr5
EP MHA6 H 6 mm - Large Gingival Profile Titanium Gr5

DMX 1/2 [Standard Torx Driver](#)

digital toronto narrow prosthetics

Componenti Toronto - Per Impronta e Modello in Gesso

Toronto Components - For Impression and Gypsum Model

EP MI Toronto Impression Abutment - Transfer Impronta

EP MAL2DS-V Toronto Analog - Analogo da Laboratorio

EP MAL2DS Toronto Digital Analog - Analogo Digitale Toronto

DMX 1/2 Standard Torx Driver



 15Ncm

Transfer Toronto per Impronta Digitale - Titanio Gr. 5

Toronto Scan Abutment - Titanium Gr. 5

EP MSA2 DS Rotating Scan Abutment - Transfer Digitale Rotante

EP MV Vite di Ricambio Toronto - Toronto Spare Screw

DMX 1/2 Standard Torx Driver



 15Ncm



Link Base per Incollaggio Rotante - Titanio Gr. 5

Rotating Bonding Technique Base Link - Titanium Gr. 5

EP MT DS Bonding Technique - Incollaggio Passivo

EP MV Vite di Ricambio Toronto - Toronto Spare Screw

DMX 1/2 Standard Torx Driver

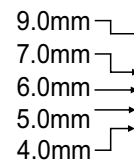

 15Ncm



Adjustable in 5 heights

Transfer per Impronta Digitale - Titanio Gr. 5 + Acidificazione

Scan Abutment - Titanium Gr. 5 + Acid Etching

IP 3SA DS Antirotaion Hex - **Narrow** Gingival Profile

IP VIT Vite di Ricambio - Spare Screw

DM 1/2 Standard Hexagonal Driver



 25Ncm



Link Base per Incollaggio - Titanio Gr. 5

Bonding Technique Base Link - Titanium Gr. 5

IP 3TB DS Antirotaion Hex - Adjustable in 3 heights

IP 3TBR DS Rotating - Adjustable in 3 heights

IP VITG Vite di Ricambio Gold - Gold Spare Screw

DM 1/2 Standard Hexagonal Driver

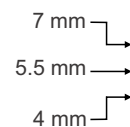

 25Ncm



Adjustable in 3 heights

Analogo per Laboratorio CAD - Titanio Gr. 5

CAD Laboratory Analog - Titanium Gr. 5

IP 3AL2DS H 10 mm - Ø 4 Universal Shape





5° MORSE CONNECTION

ANTI-ROTATION HEXAGON

ONESEAL
TAPERED SHAPE



IBK

subcrestal surgical approach

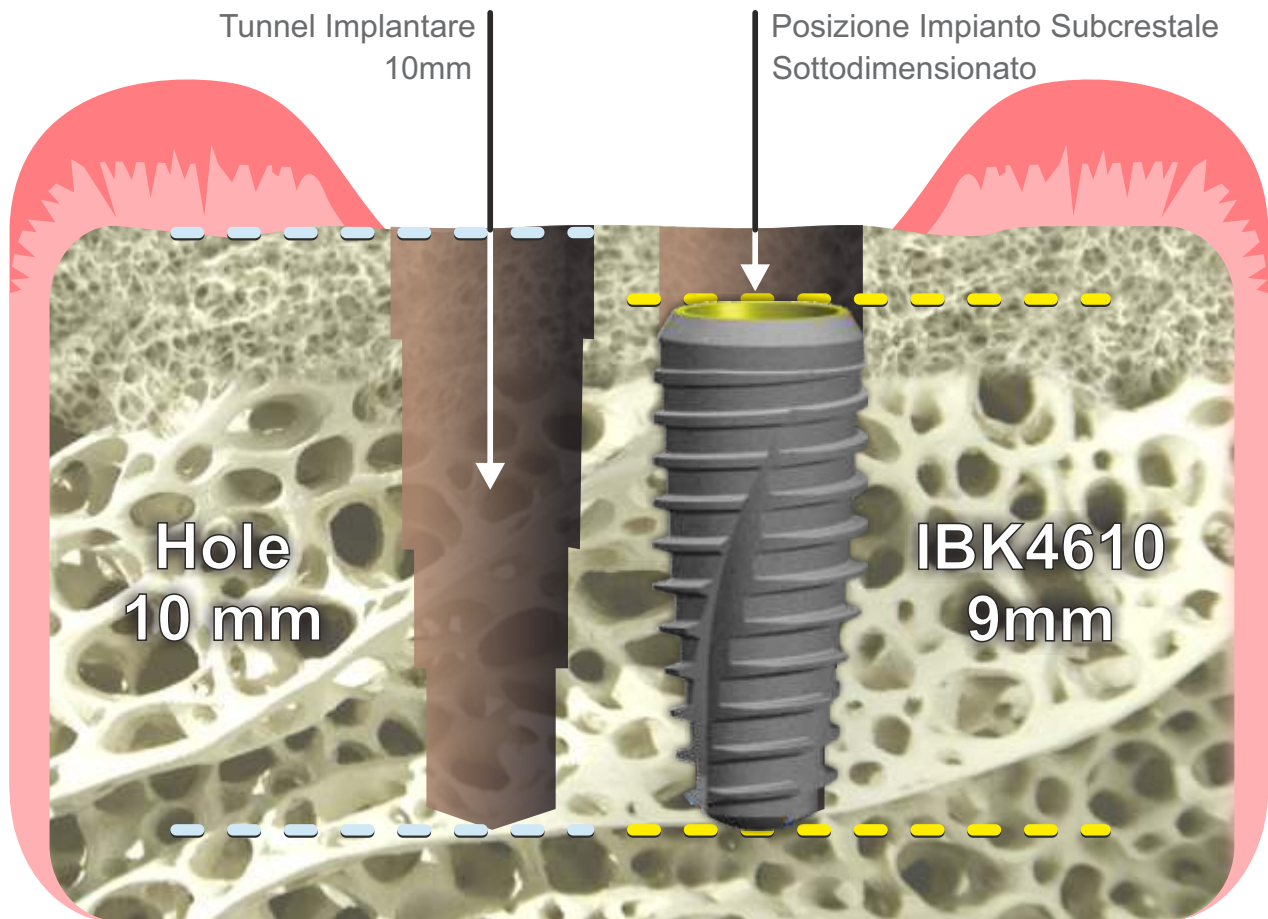

✓ Influence of subcrestal implant placement compared with equicrestal position on the peri-implant hard and soft tissues around platform-switched implants: a systematic review and meta-analysis.
 Valles C, Rodríguez-Ciurana X, Clementini M, Baglivo M, Paniagua B, Nart J.
 Clin Oral Investig. 2018 Mar;22(2):555-570. doi: 10.1007/s00784-017-2301-1. Epub 2018 Jan 8.

MARGINAL BONE PRESERVATION PROTOCOL

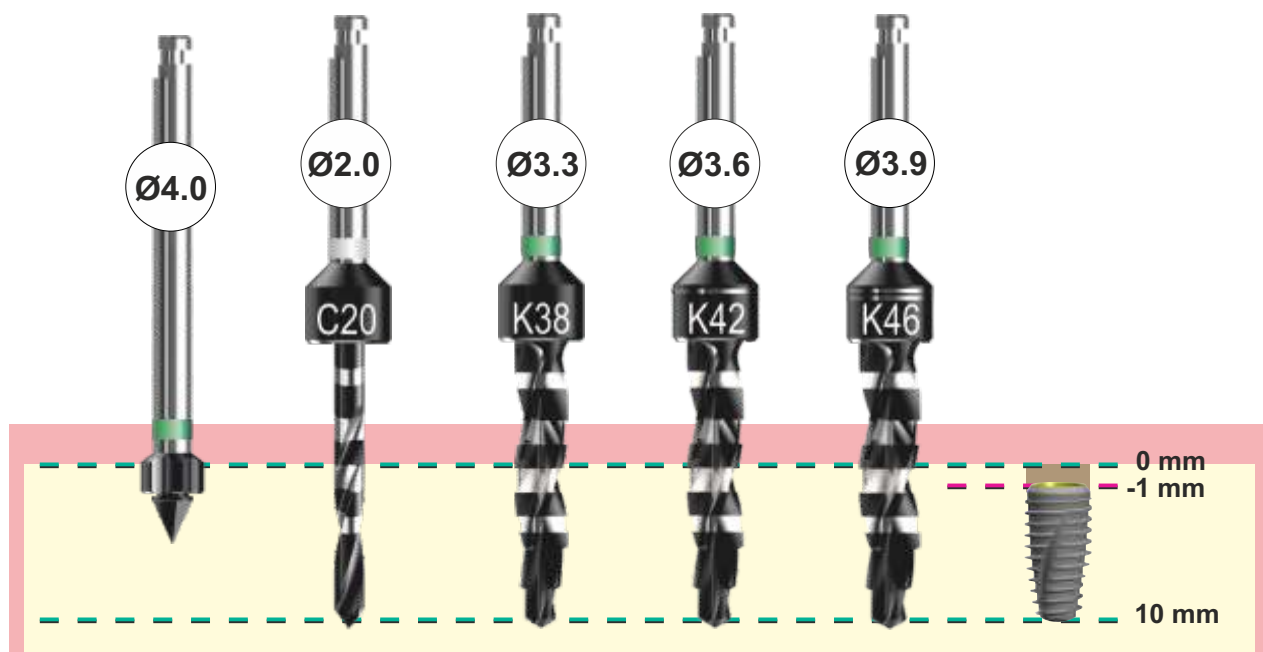

subcrestal surgical approach

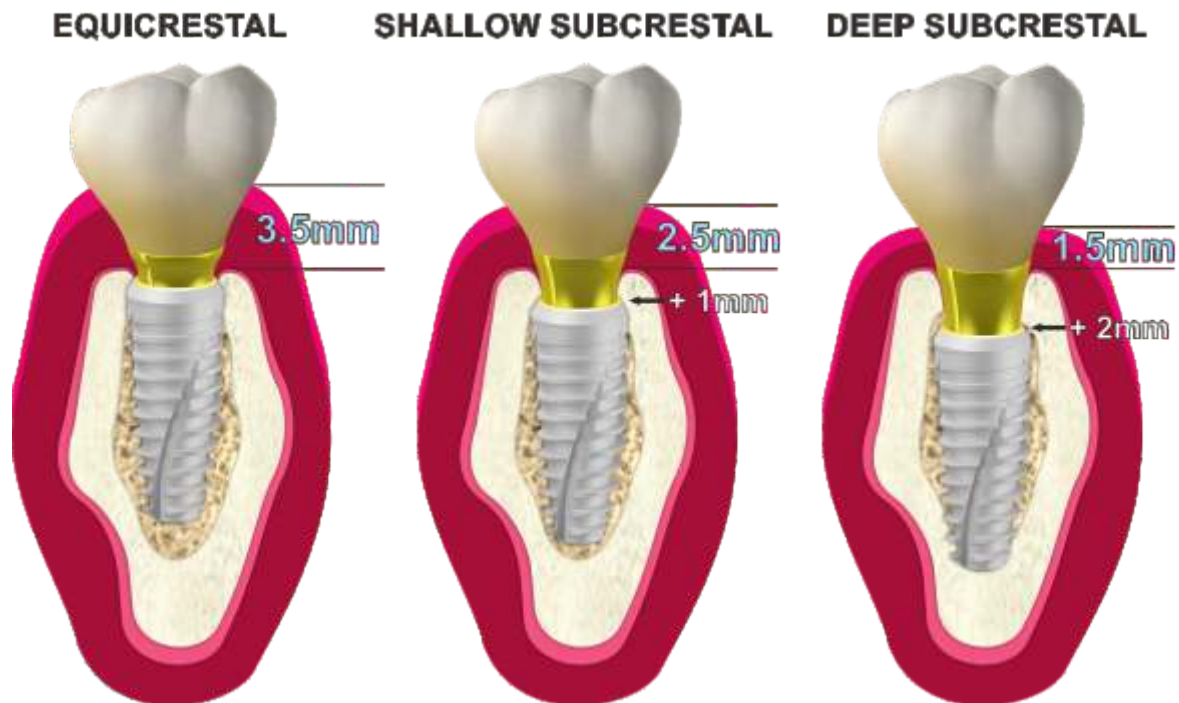

Gli impianti possono essere inseriti sub-crestali, confinando il riassorbimento osseo alla sola porzione coronale, senza l'esposizione della superficie ruvida,¹ le stesse considerazioni valgono per gli impianti tissue-level²

- ✓ 1) **Bone remodeling and bone loss around subcrestal implants: Two distinct entities.**
Spinato S, Lombardi T, Stacchi C.
Int J Periodontics Restorative Dent. 2023;43(4):410-411.
- ✓ 2) **Influence of apico-coronal positioning of tissue-level implants on marginal bone stability during supracrestal tissue height establishment: A multi-center prospective study.**
Spinato S, Bernardello F, Lombardi T, Soardi CM, Messina M, Zaffe D, Stacchi C.
Clin Implant Dent Relat Res. 2022;24(5):611-620.

transgingival oneabutment approach

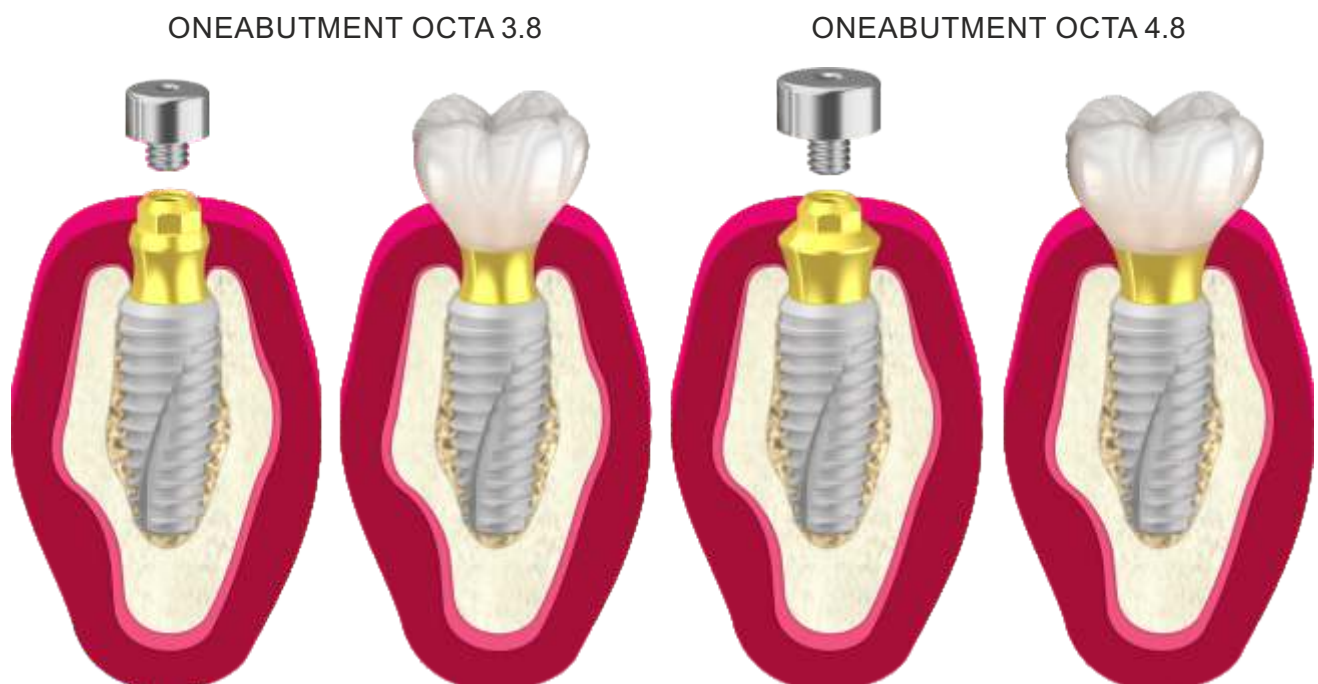

IBK 34



ONESEAL TAPERED SHAPE 5° Morse Connection

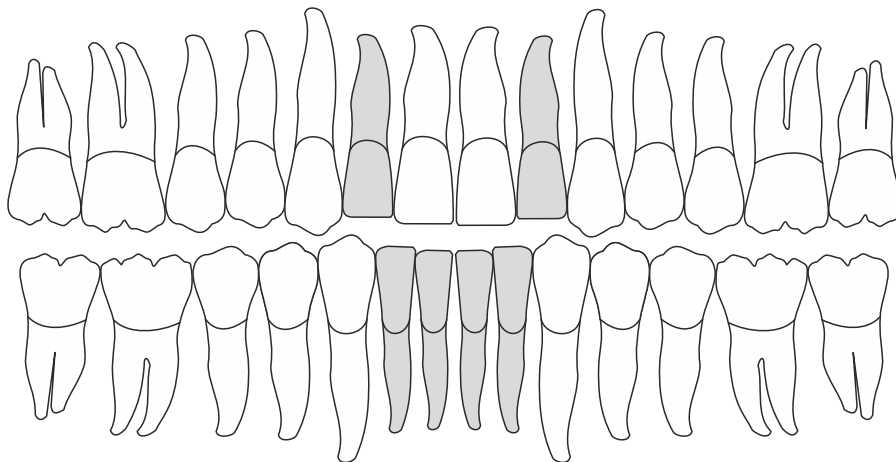
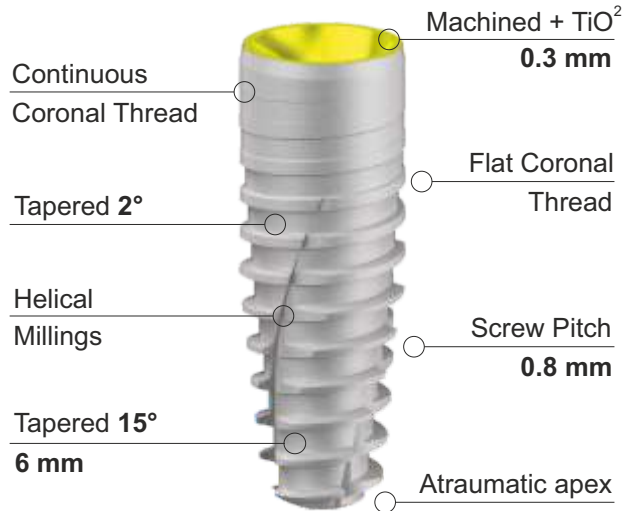

SOFT BONE - D4



STD BONE - D3/D2



HARD BONE - D1



Velocità di rotazione frese consigliata 500 - 800 rpm

Recommended milling burs rotation speed 500 - 800 rpm

IBK 38

MAX
70 Ncm

ONESEAL TAPERED SHAPE 5° Morse Connection

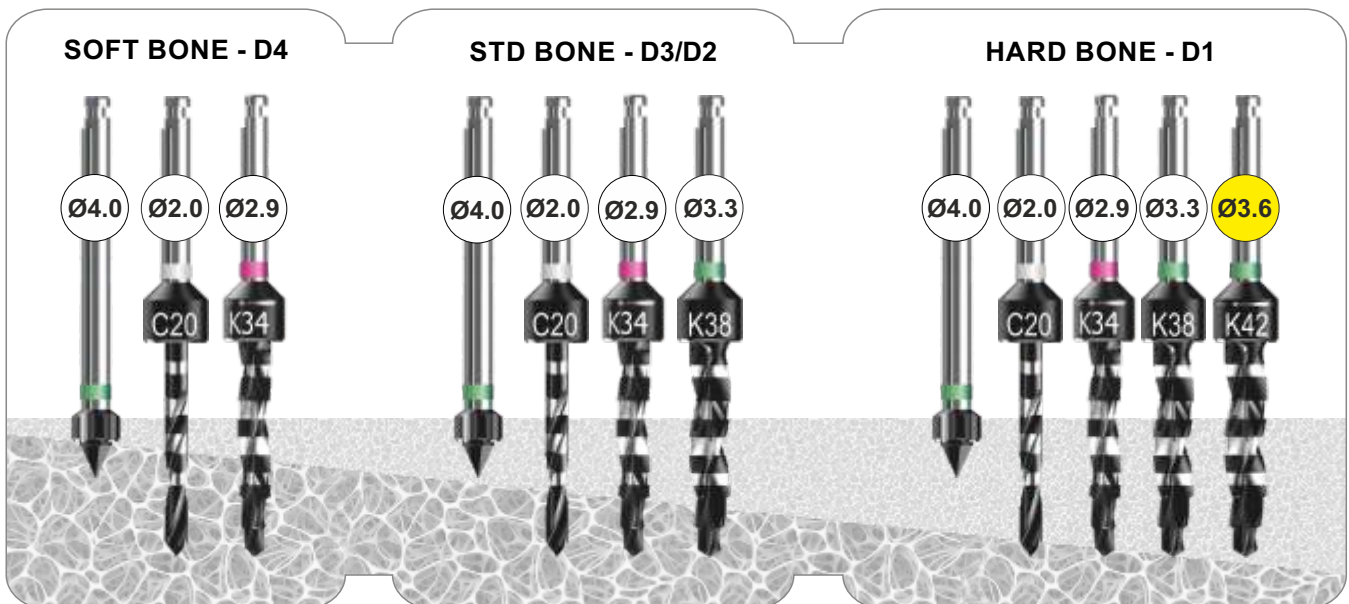
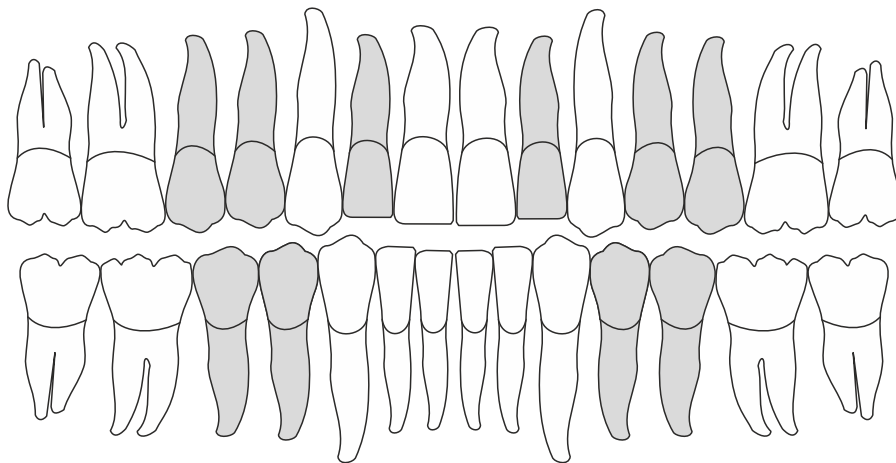
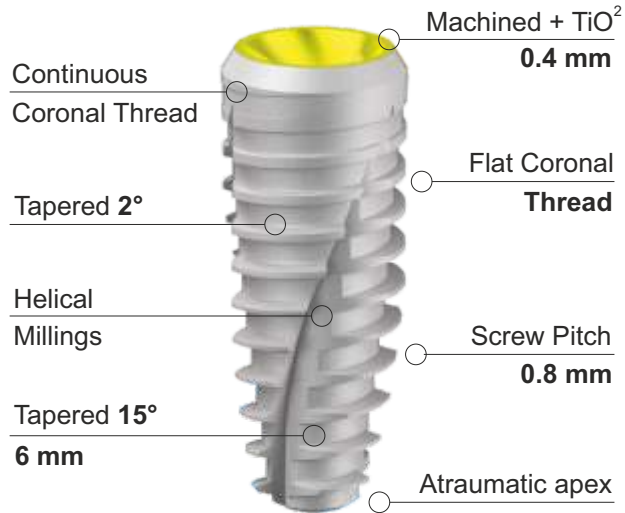

Velocità di rotazione frese consigliata 500 - 800 rpm

Recommended milling burs rotation speed 500 - 800 rpm

IBK 42

MAX
70 Ncm

ONESEAL TAPERED SHAPE 5° Morse Connection

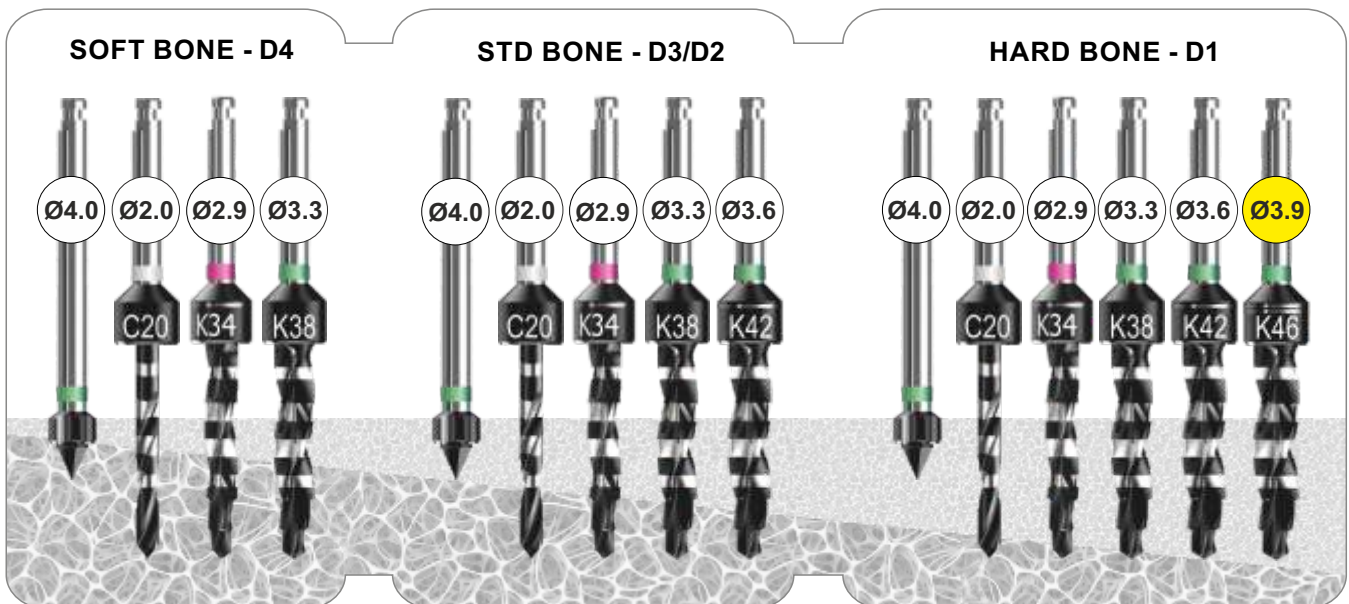
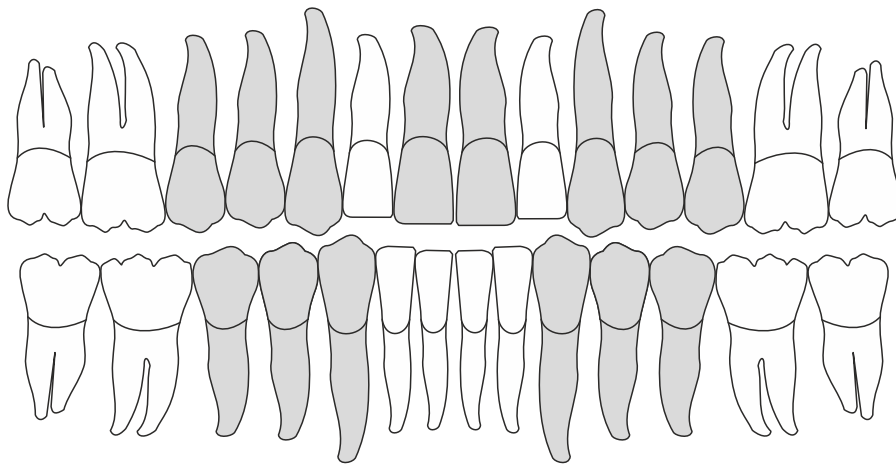
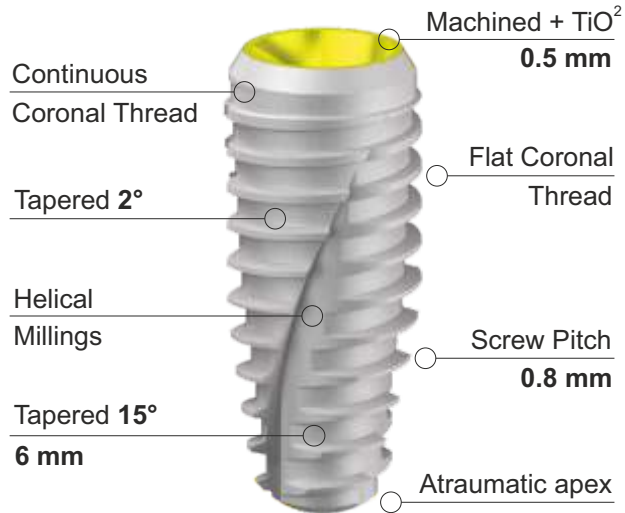

Velocità di rotazione frese consigliata 500 - 800 rpm

Recommended milling burs rotation speed 500 - 800 rpm

IBK 46



ONESEAL TAPERED SHAPE 5° Morse Connection

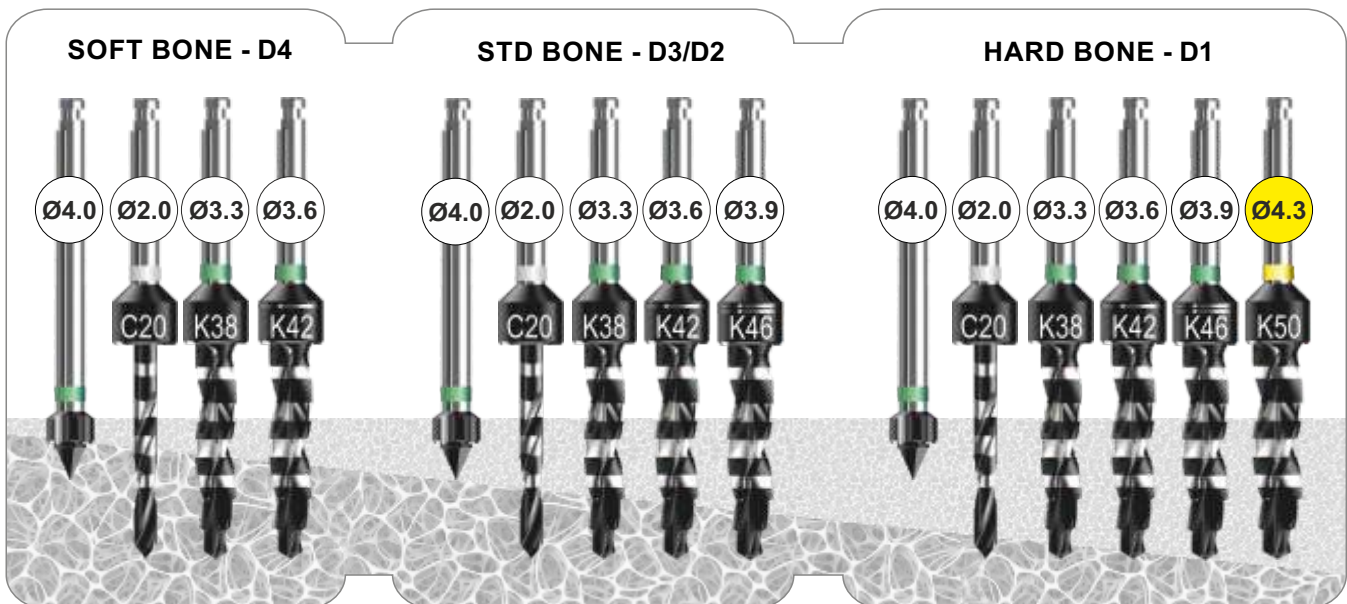
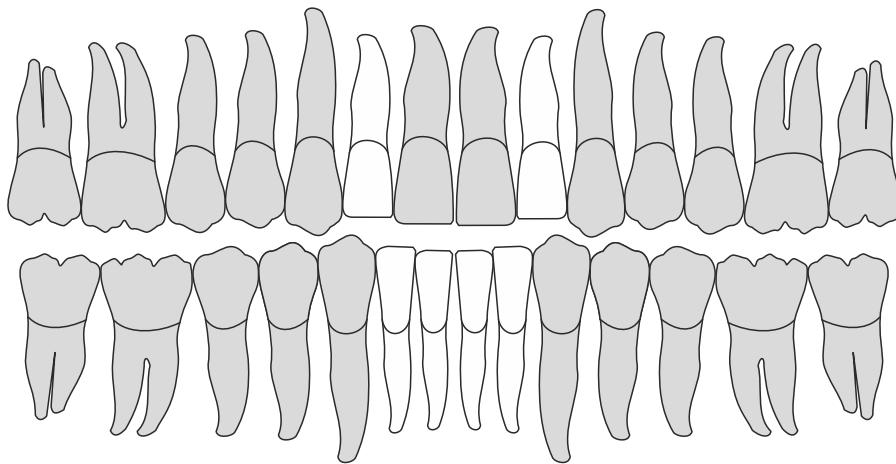
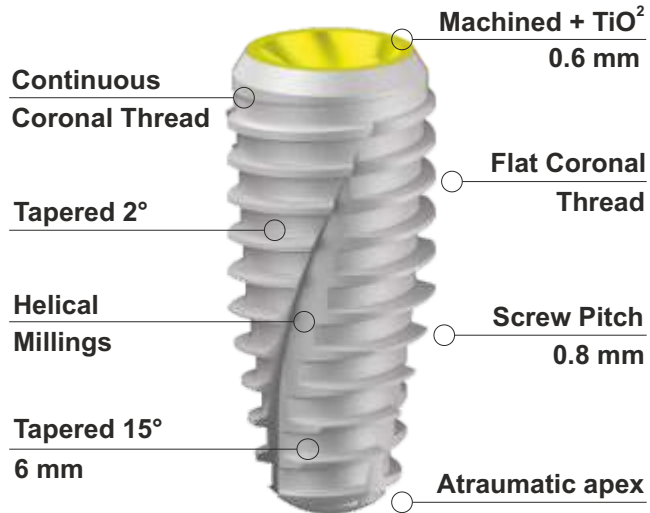

Velocità di rotazione frese consigliata 500 - 800 rpm

Recommended milling burs rotation speed 500 - 800 rpm

IBK 50



ONESEAL TAPERED SHAPE 5° Morse Connection

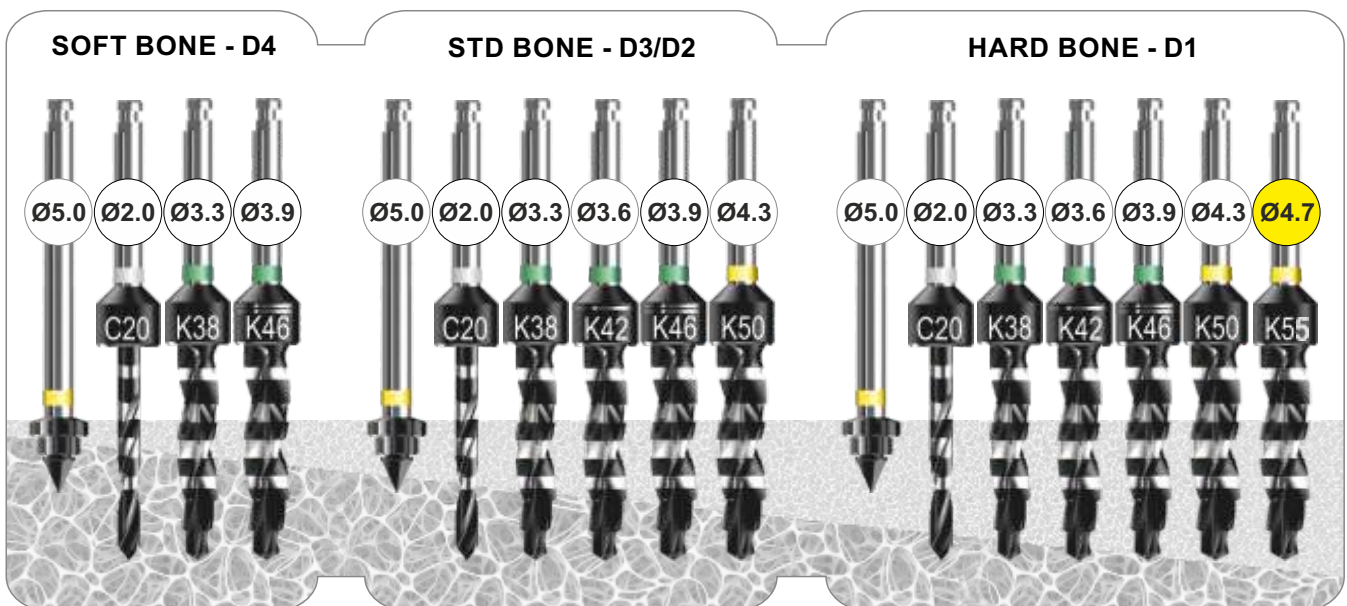
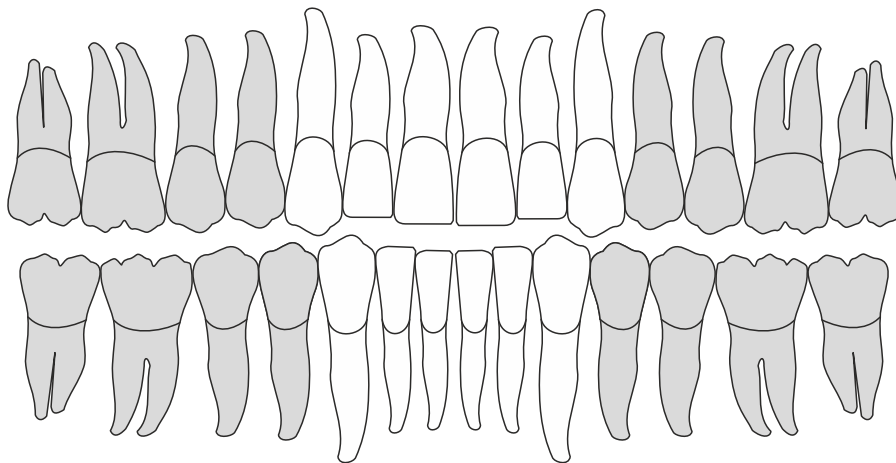
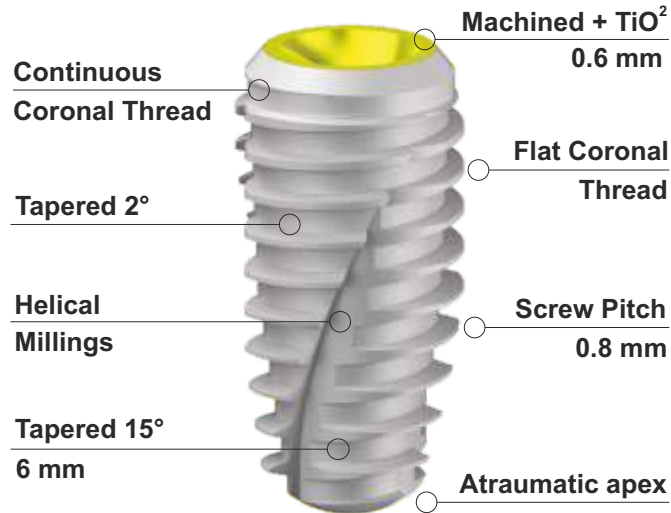

Velocità di rotazione frese consigliata 500 - 800 rpm

Recommended milling burs rotation speed 500 - 800 rpm

3.4 Full Treatment - Mounterless



CODE	IMPLANT	LENGTH	NECK	APEX
IBK 3408	Ø 3.4	7.5 mm	Ø 3.6	Ø 1.8
IBK 3410	Ø 3.4	9 mm	Ø 3.6	Ø 1.8
IBK 3411	Ø 3.4	10.5 mm	Ø 3.6	Ø 1.8
IBK 3413	Ø 3.4	12 mm	Ø 3.6	Ø 1.8
IBK 3415	Ø 3.4	14 mm	Ø 3.6	Ø 1.8

3.8 Full Treatment - Mounterless



CODE	IMPLANT	LENGTH	NECK	APEX
IBK 3808	Ø 3.8	7.5 mm	Ø 4.1	Ø 1.9
IBK 3810	Ø 3.8	9 mm	Ø 4.1	Ø 1.9
IBK 3811	Ø 3.8	10.5 mm	Ø 4.1	Ø 1.9
IBK 3813	Ø 3.8	12 mm	Ø 4.1	Ø 1.9
IBK 3815	Ø 3.8	14 mm	Ø 4.1	Ø 1.9

4.2 Full Treatment - Mounterless



CODE	IMPLANT	LENGTH	NECK	APEX
IBK 4208	Ø 4.2	7.5 mm	Ø 4.1	Ø 2.3
IBK 4210	Ø 4.2	9 mm	Ø 4.1	Ø 2.3
IBK 4211	Ø 4.2	10.5 mm	Ø 4.1	Ø 2.3
IBK 4213	Ø 4.2	12 mm	Ø 4.1	Ø 2.3
IBK 4215	Ø 4.2	14 mm	Ø 4.1	Ø 2.3

4.6 Full Treatment - Mounterless



CODE	IMPLANT	LENGTH	NECK	APEX
IBK 4608	Ø 4.6	7.5 mm	Ø 4.3	Ø 2.6
IBK 4610	Ø 4.6	9 mm	Ø 4.3	Ø 2.6
IBK 4611	Ø 4.6	10.5 mm	Ø 4.3	Ø 2.6
IBK 4613	Ø 4.6	12 mm	Ø 4.3	Ø 2.6
IBK 4615	Ø 4.6	14 mm	Ø 4.3	Ø 2.6

5.0 Full Treatment - Mounterless



CODE	IMPLANT	LENGTH	NECK	APEX
IBK 5008	Ø 5.0	7.5 mm	Ø 4.7	Ø 3.0
IBK 5010	Ø 5.0	9 mm	Ø 4.7	Ø 3.0
IBK 5011	Ø 5.0	10.5 mm	Ø 4.7	Ø 3.0
IBK 5013	Ø 5.0	12 mm	Ø 4.7	Ø 3.0
IBK 5015	Ø 5.0	14 mm	Ø 4.7	Ø 3.0



5° MORSE CONNECTION

ANTI-ROTATION HEXAGON

BANP
TWIN LINE



IM



IC

IM 40

ACTIVE SHAPE
5° Morse Connection

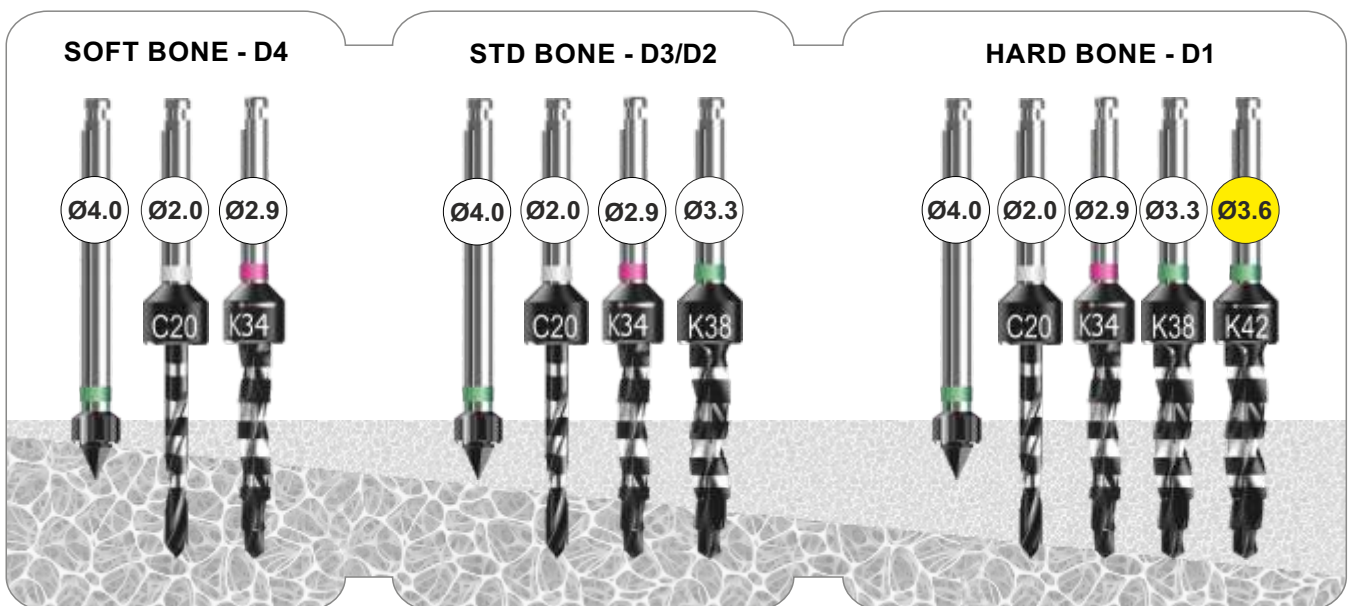
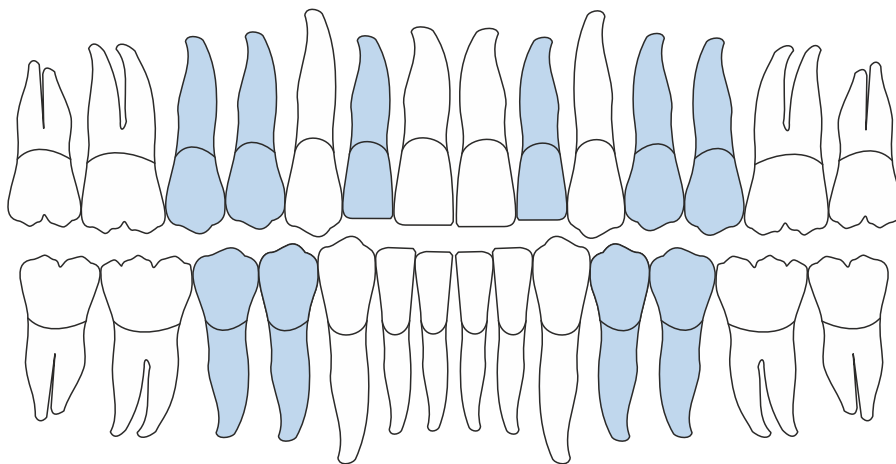
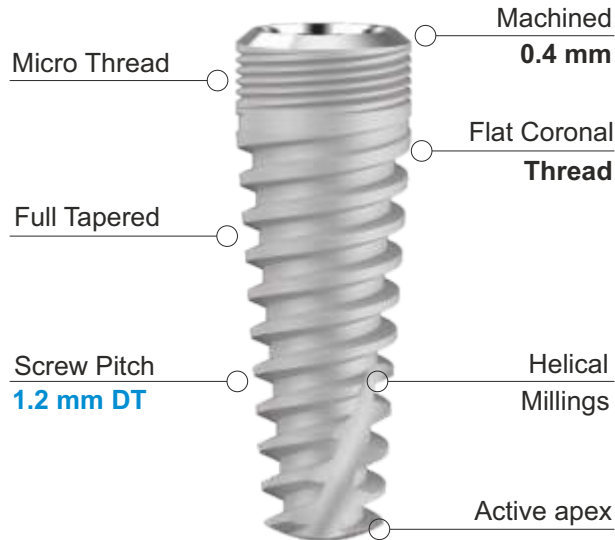

Velocità di rotazione frese consigliata 500 - 800 rpm

Recommended milling burs rotation speed 500 - 800 rpm

3.5 Full Treatment - Mounterless



CODE	IMPLANT	LENGTH	NECK	APEX
IM 3585	Ø 3.4	8.5 mm	Ø 3.5	Ø 2.2
IM 3510	Ø 3.4	10 mm	Ø 3.5	Ø 2.2
IM 3512	Ø 3.4	12 mm	Ø 3.5	Ø 2.2
IM 3513	Ø 3.4	13 mm	Ø 3.5	Ø 2.2

4.0 Full Treatment - Mounterless



CODE	IMPLANT	LENGTH	NECK	APEX
IM 4085	Ø 3.8	8.5 mm	Ø 4.0	Ø 2.7
IM 4010	Ø 3.8	10 mm	Ø 4.0	Ø 2.7
IM 4012	Ø 3.8	12 mm	Ø 4.0	Ø 2.7
IM 4013	Ø 3.8	13 mm	Ø 4.0	Ø 2.7

4.5 Full Treatment - Mounterless



CODE	IMPLANT	LENGTH	NECK	APEX
IM 4585	Ø 4.3	8.5 mm	Ø 4.5	Ø 3.2
IM 4510	Ø 4.3	10 mm	Ø 4.5	Ø 3.2
IM 4512	Ø 4.3	12 mm	Ø 4.5	Ø 3.2
IM 4513	Ø 4.3	13 mm	Ø 4.5	Ø 3.2

5.0 Full Treatment - Mounterless



CODE	IMPLANT	LENGTH	NECK	APEX
IM 5085	Ø 4.8	8.5 mm	Ø 5.0	Ø 3.7
IM 5010	Ø 4.8	10 mm	Ø 5.0	Ø 3.7
IM 5012	Ø 4.8	12 mm	Ø 5.0	Ø 3.7
IM 5013	Ø 4.8	13 mm	Ø 5.0	Ø 3.7

IC 40

CYLINDRICAL SHAPE 5° Morse Connection

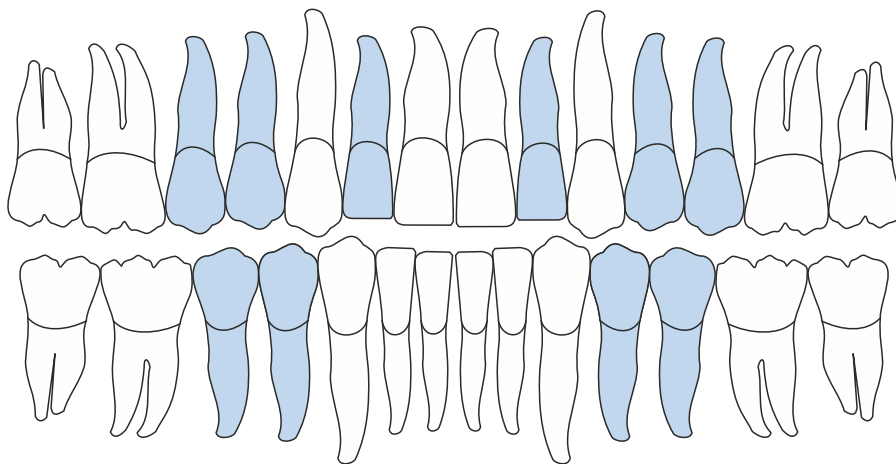
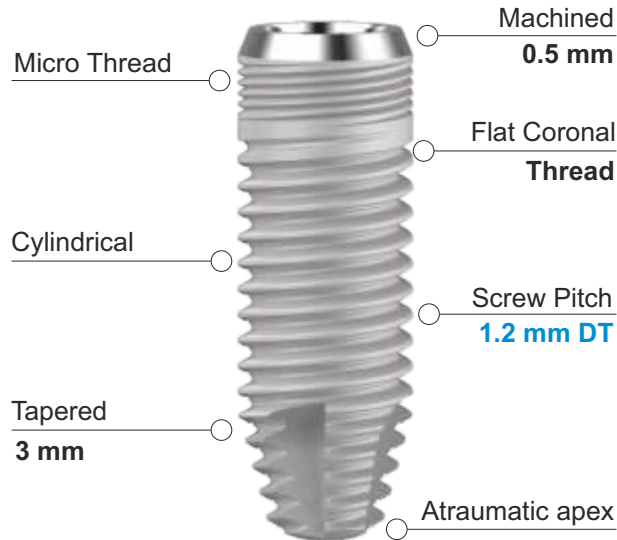

SOFT BONE - D4



STD BONE - D3/D2



HARD BONE - D1

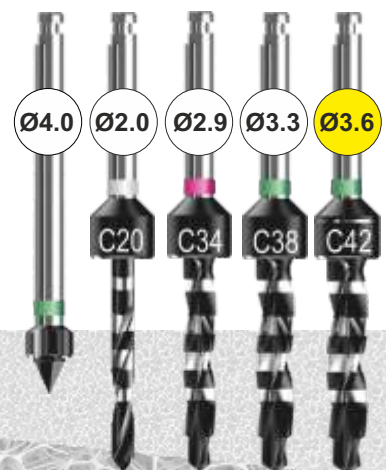

Velocità di rotazione frese consigliata 500 - 800 rpm

Recommended milling burs rotation speed 500 - 800 rpm

3.5 Full Treatment - Mounterless



CODE	IMPLANT	LENGTH	NECK	APEX
IC 3585	Ø 3.4	8.5 mm	Ø 3.5	Ø 2.2
IC 3510	Ø 3.4	10 mm	Ø 3.5	Ø 2.2
IC 3512	Ø 3.4	12 mm	Ø 3.5	Ø 2.2
IC 3513	Ø 3.4	13 mm	Ø 3.5	Ø 2.2

4.0 Full Treatment - Mounterless



CODE	IMPLANT	LENGTH	NECK	APEX
IC 4085	Ø 3.8	8.5 mm	Ø 4.0	Ø 2.7
IC 4010	Ø 3.8	10 mm	Ø 4.0	Ø 2.7
IC 4012	Ø 3.8	12 mm	Ø 4.0	Ø 2.7
IC 4013	Ø 3.8	13 mm	Ø 4.0	Ø 2.7

4.5 Full Treatment - Mounterless



CODE	IMPLANT	LENGTH	NECK	APEX
IC 4585	Ø 4.3	8.5 mm	Ø 4.5	Ø 3.2
IC 4510	Ø 4.3	10 mm	Ø 4.5	Ø 3.2
IC 4512	Ø 4.3	12 mm	Ø 4.5	Ø 3.2
IC 4513	Ø 4.3	13 mm	Ø 4.5	Ø 3.2

5.0 Full Treatment - Mounterless



CODE	IMPLANT	LENGTH	NECK	APEX
IC 5085	Ø 4.8	8.5 mm	Ø 5.0	Ø 3.7
IC 5010	Ø 4.8	10 mm	Ø 5.0	Ø 3.7
IC 5012	Ø 4.8	12 mm	Ø 5.0	Ø 3.7
IC 5013	Ø 4.8	13 mm	Ø 5.0	Ø 3.7

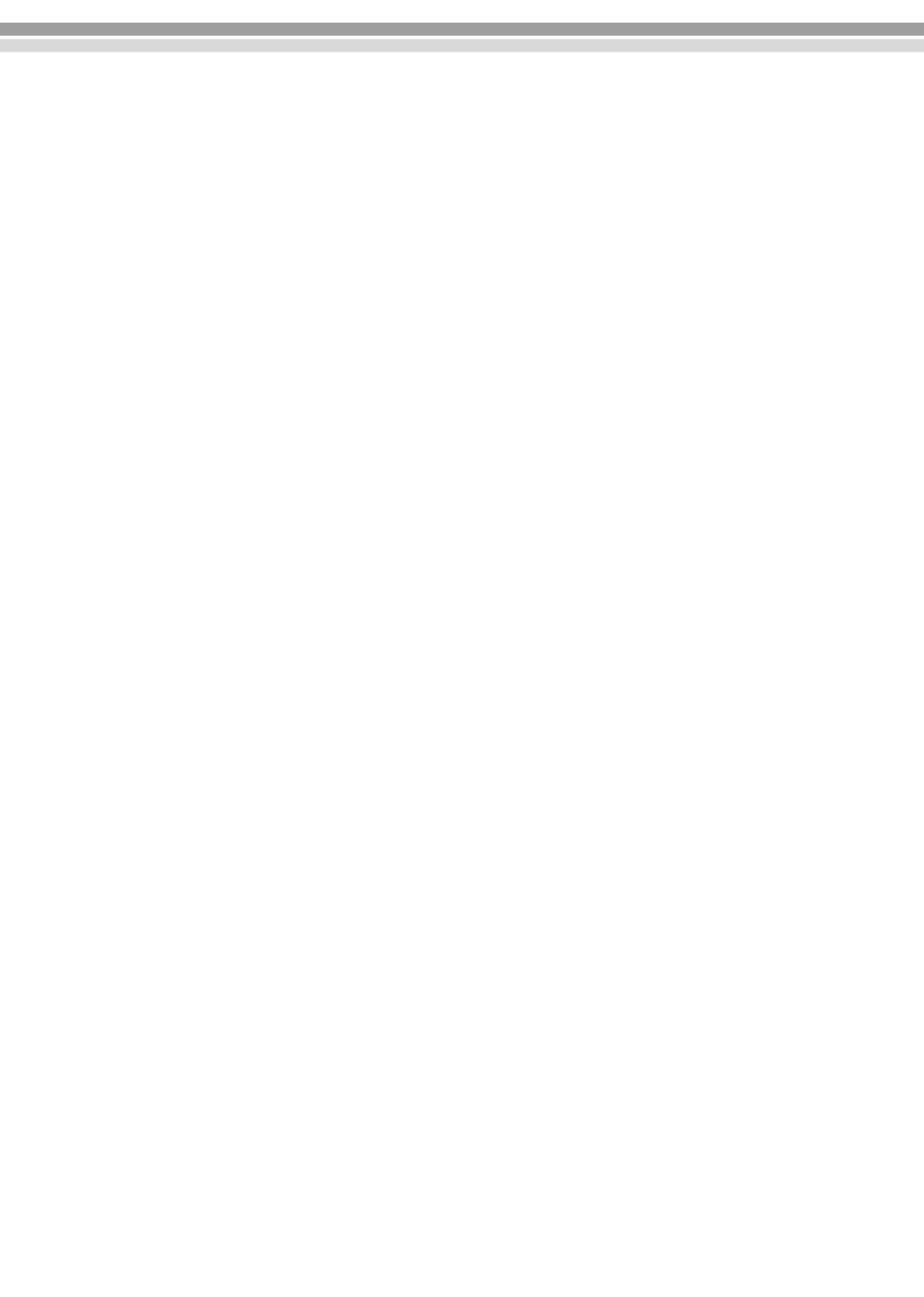

PROSTHETICS COMPONENTS

UNIVERSAL 5° MORSE CONNECTION

IBK - IM - IC



prosthetics parts

20Ncm 



Pilastro di Guarigione STANDARD - Titanio Gr. 5

STANDARD Healing Abutment - Titanium Gr. 5

VI 3000 H 3 mm - Standard Gingival Profile Ø 4.5

VI 5000 H 5 mm - Standard Gingival Profile Ø 4.5

VI 7000 H 7 mm - Standard Gingival Profile Ø 4.5

DMRP120S Standard Hexagonal Driver Ø 1.20

20Ncm 



Pilastro di Guarigione ANATOMICO - Titanio Gr. 5

ANATOMICAL Healing Abutment - Titanium Gr. 5

VI 30SV H 3 mm - Anatomical Gingival Profile Ø 5.0

VI 50SV H 5 mm - Anatomical Gingival Profile Ø 5.0

DMRP120S Standard Hexagonal Driver Ø 1.20

20Ncm 



Pilastro di Guarigione Largo ANATOMICO - Titanio Gr. 5

ANATOMICAL Large Healing Abutment - Titanium Gr. 5

VI 6030 H 3 mm - Anatomical Large Gingival Profile Ø 6.0

VI 6050 H 5 mm - Anatomical Large Gingival Profile Ø 6.0

DMRP120S Standard Hexagonal Driver Ø 1.20

Analogo per Laboratorio - Titanio Gr. 5 - Anodizzato

Laboratory Analog - Titanium Gr. 5 - Anodized

AN 1000 H 12 mm - Universal Shape



15Ncm 



Transfer per impronta Pick Up - Titanio Gr. 5

Pick Up Impression Coping - Titanium Gr. 5

TR 1000 Antirotation Hex

VITR00 Vite Lunga di Ricambio - Long Spare Screw

DMRP120S Standard Hexagonal Driver Ø 1.20

prosthetics parts

Transfer per Impronta a Strappo Cucchiaino Chiuso - Titanio Gr. 5

Closed Tray Impression Coping - Titanium Gr. 5

TR 1100 Antirotation Hex

TRS 1100 Snap-On

VIPA00 Vite di Ricambio - Spare Screw

DMRP120S Standard Hexagonal Driver Ø 1.20

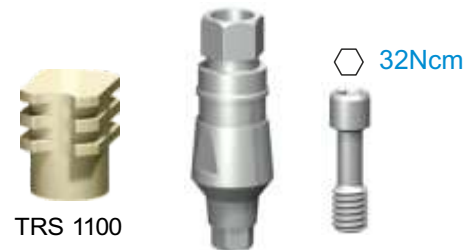

Pilastro Temporaneo da Incollaggio - Titanio Gr. 5

Temporary Glueing Abutment - Titanium Gr. 5

MT 1000 Temporary Glueing Antirotation Hex - H1mm

MTR 1000 Temporary Glueing Rotating - H1mm

MOFL 00 Temporary Glueing **FLAT** - Rotating - H1mm

VPF00 Vite di Ricambio - Spare Screw

DMRP120S Standard Hexagonal Driver Ø 1.20

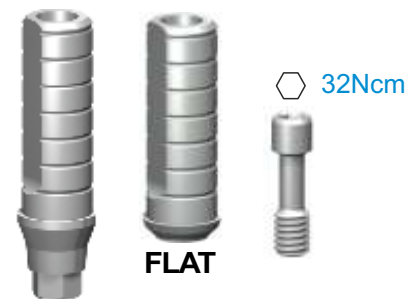

Moncone Titanio Dritto - Titanio Gr. 5

Straight Titanium Abutment - Titanium Gr. 5

MDN 1000 Straight - Antirotation Hex - Narrow Gingival Profile H1.5mm

VIPA00 Vite di Ricambio - Spare Screw

DMRP120S Standard Hexagonal Driver Ø 1.20



Moncone Titanio Dritto Fresabile - Titanio Gr. 5

Straight Millable Titanium Abutment - Titanium Gr. 5

MD 1000 Straight - Antirotation Hex - Ø 5.0 Gingival Profile H2mm

MD 1040 Straight - Antirotation Hex - Ø 5.0 Gingival Profile H4mm

MD 1050 Straight - Antirotation Hex - Ø 5.0 Gingival Profile H5mm

VIPA00 Vite di Ricambio - Spare Screw

DMRP120S Standard Hexagonal Driver Ø 1.20



Moncone Titanio Dritto Spallato - Titanio Gr. 5

Straight Shouldered Titanium Abutment - Titanium Gr. 5

MA 1000 Straight - Antirotation Hex - Ø 5.0 Gingival Profile H2mm

MA 1040 Straight - Antirotation Hex - Ø 5.0 Gingival Profile H4mm

VIPA00 Vite di Ricambio - Spare Screw

DMRP120S Standard Hexagonal Driver Ø 1.20



prosthetics parts

32Ncm



Moncone Titanio Dritto Spallato - Titanio Gr. 5

Shoulder Straight Titanium Abutment - Titanium Gr. 5

MD 6020 Large Ø 6.0 Gingival Profile - H 2 mm

MD 6040 Large Ø 6.0 Gingival Profile - H 4 mm

VIPA00 Vite di Ricambio - Spare Screw

DMRP120S Standard Hexagonal Driver Ø 1.20

32Ncm



Moncone Titanio Angolato 15° - Titanio Gr. 5

15° Angled Titanium Abutment - Titanium Gr. 5

MA 1500 Ø 5.0 Gingival Profile - H 2 mm

MA 1540 Ø 5.0 Gingival Profile - H 4 mm

VIPA00 Vite di Ricambio - Spare Screw

DMRP120S Standard Hexagonal Driver Ø 1.20

32Ncm



Moncone Titanio Angolato 25° - Titanio Gr. 5

25° Angled Titanium Abutment - Titanium Gr. 5

MA 2500 Ø 5.0 Gingival Profile - H 2 mm

MA 2540 Ø 5.0 Gingival Profile - H 4 mm

VIPA00 Vite di Ricambio - Spare Screw

DMRP120S Standard Hexagonal Driver Ø 1.20

32Ncm

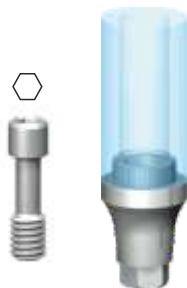

Link in Titanio con Calcinabile - Titanio Gr. 5

Titanium Link with Castable Abutment - Titanium Gr. 5

CA 10TI Antirotation Hex - Ø 5.0 Gingival Profile H3mm

VIPA00 Vite di Ricambio - Spare Screw

DMRP120S Standard Hexagonal Driver Ø 1.20

32Ncm

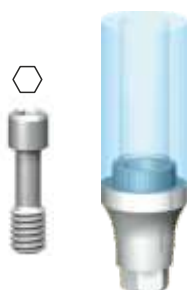

Moncone UCLA Cobalto Cromo - CoCr

UCLA Abutment Cobalt Chrome - CoCr

CA 10CR Antirotation Hex - Ø 5.0 Gingival Profile H3mm

CR 10CR Rotating - Ø 5.0 Gingival Profile H3mm

CAS 10CR Antirotation Hex - Ø 5.0 Gingival Profile H2mm

VIPA00 Vite di Ricambio - Spare Screw

DMRP120S Standard Hexagonal Driver Ø 1.20

prosthetics parts

Moncone Calcinabile - Acrilico

Castable Abutment - Acrylic

CA 1000 Antirotation Hex - Ø 5.0 Gingival Profile H2mm

CR 1000 Rotating - Ø 5.0 Gingival Profile H2mm

VIPA00 Vite di Ricambio - Spare Screw

DMRP120S Standard Hexagonal Driver Ø 1.20

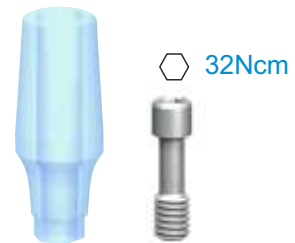

Pilastri a Sfera per Overdenture - Titanio Gr. 5

Overdenture Ball Abutments - Titanium Gr. 5

MO 0001 Normo - Ø 4.5 Gingival Profile H1mm

MO 0003 Normo - Ø 4.5 Gingival Profile H3mm

MO 0005 Normo - Ø 4.5 Gingival Profile H5mm

DMRP120S Standard Hexagonal Driver Ø 1.20



Cappette Ritentive Normo - Teflon

Normo Retentive Caps - Teflon

TF 10 Bianca - White 1300 gr

TF 08 Rosa - Pink 800 gr

TF 06 Gialla - Yellow 600 gr

TF 04 Verde - Green 400 gr



Contenitore Metallico per Cappette Ritentive Normo

Normo Retentive Caps Metal Box

CO 01 Stainless Steel Metal Box

CO 02 Titanium Metal Box

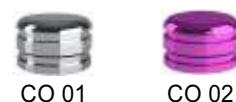

Kit Pilastro Equator per Overdenture - Titanio Gr. 5 - PVD TiN

Overdenture Equator Abutment Kit - Titanium Gr. 5 - PVD TiN

BPEQ1 H 1 mm - Narrow Gingival Profile

BPEQ2 H 2 mm - Narrow Gingival Profile

BPEQ3 H 3 mm - Narrow Gingival Profile

BPEQ4 H 4 mm - Narrow Gingival Profile

BPEQ5 H 5 mm - Narrow Gingival Profile



32Ncm



Transfer per impronta Digitale - Titanio Gr. 5

Scan Abutment - Titanium Gr. 5

SCA 00 Ø 4.5 Gingival Profile

VIPA00 Vite di Ricambio - Spare Screw

DMRP120S Standard Hexagonal Driver Ø 1.20

Analogo CAD da Laboratorio con Vite - Titanio Gr. 5

Laboratory CAD Analog with Screw - Titanium Gr. 5

AN3D 00 Con vite ritentiva per modelli stampati



32Ncm



VIPA00

Link Base per Incollaggio Antirotazione - Titanio Gr. 5

Antirotation Bonding Technique Base Link - Titanium Gr. 5

LK 1001 Gingival Profile **H 1mm** - Antirotation Hex

LK 1002 Gingival Profile **H 2mm** - Antirotation Hex

LK 1003 Gingival Profile **H 3mm** - Antirotation Hex

LK 1004 Gingival Profile **H 4mm** - Antirotation Hex

LK 1005 Gingival Profile **H 5mm** - Antirotation Hex

Link Base per Incollaggio Rotante - Titanio Gr. 5

Rotating Bonding Technique Base Link - Titanium Gr. 5

LKR 1001 Gingival Profile **H 1mm** - Rotating

LKR 1002 Gingival Profile **H 2mm** - Rotating

LKR 1003 Gingival Profile **H 3mm** - Rotating

LKR 1004 Gingival Profile **H 4mm** - Rotating

LKR 1005 Gingival Profile **H 5mm** - Rotating

DMRP120S Standard Hexagonal Driver Ø 1.20

32Ncm



VIPA00

Viti protesiche per canale angolato - Titanio Gr. 5

Prosthetic screws for angled hole - Titanium Gr. 5

VIPA 00AI Vite Standard per canale angolato - STANDARD

VIPA 00AITL Vite Lunga + 2mm per canale angolato - LONG

20Ncm

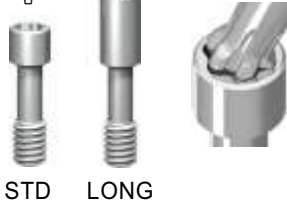

STD

LONG

MDT6DS Manual Torque Driver for angled hole

DCT6DS RA Contr-angle Torque Driver for angled hole

Link Aperti da incollaggio per Avvitamento Angolato - Titanio Gr. 5

Open Links for Gluing for Angled Screwing - Titanium Gr. 5

IPB TBAI1 Gingival Profile H 1.7mm - Antirotation Hex

IPB TBAI2 Gingival Profile H 2.5mm - Antirotation Hex

IPB TBRAI1 Gingival Profile H 1.7mm - Rotating

IPB TBRAI2 Gingival Profile H 2.5mm - Rotating

MDT6DS Manual Torque Driver for angled hole

DCT6DS RA Contr-angle Torque Driver for angled hole



Link per Incollaggio - Compatibile Cerec - Titanio Gr. 5

Bonding Technique Link - Cerec Compatible - Titanium Gr. 5

IPB STB1 Gingival Profile H 1.0mm - Antirotation Hex

IPB STB2 Gingival Profile H 2.0mm - Antirotation Hex

IPB STB3 Gingival Profile H 3.0mm - Antirotation Hex

IPB STBR1 Gingival Profile H 1.0mm - Rotating

IPB STBR2 Gingival Profile H 2.0mm - Rotating

IPB STBR3 Gingival Profile H 3.0mm - Rotating

VIPA00 Vite di Ricambio - Spare Screw

DMRP120S Standard Hexagonal Driver Ø 1.20



AVVITAMENTO ANGOLATO CON T6 ANGLED TORX DRIVER



Max 25°
Max 20 Ncm

DM T6DS
T6 Angled Torx Driver



RICHIEDERE LE LIBRERIE PER CANALE
CON CORREZIONE ANGOLARE

toronto prosthetics

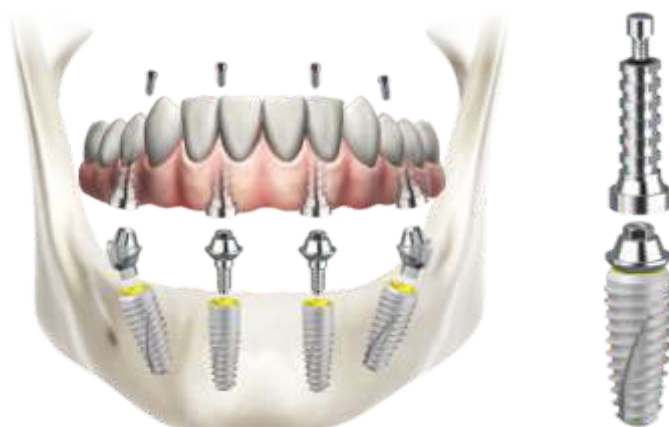

Pilastro Toronto Diritto - Titanio Gr. 5

Toronto Straight Abutment - Titanium Gr. 5

- MU 0001** Toronto Straight MUA Abutment H 1mm
- MU 0002** Toronto Straight MUA Abutment H 2mm
- MU 0003** Toronto Straight MUA Abutment H 3mm
- MU 0004** Toronto Straight MUA Abutment H 4mm
- MU 0005** Toronto Straight MUA Abutment H 5mm
- MU 0006** Toronto Straight MUA Abutment H 6mm

DCDM Toronto Straight Abutment Driver

32Ncm 



Pilastro Toronto Angolato 17° - Titanio Gr. 5

17° Toronto Angled Abutment - Titanium Gr. 5

- MU 1700** Toronto Angled 17° MUA Abutment H3
- MU 1750** Toronto Angled 17° MUA Abutment H5

VIPA00 Vite di Ricambio - Spare Screw

DMRP120S Standard Hexagonal Driver Ø 1.20

32Ncm 



Pilastro Toronto Angolato 30° e 45° - Titanio Gr. 5

30° and 45° Toronto Angled Abutment - Titanium Gr. 5

- MU 3000** Toronto Angled 30° MUA Abutment H3
- MU 3050** Toronto Angled 30° MUA Abutment H5
- MU 4500** Toronto Angled 45° MUA Abutment H4.5

VIPA00 Vite di Ricambio - Spare Screw

DMRP120S Standard Hexagonal Driver Ø 1.20

15Ncm 



Pilastro di Guarigione Toronto

Toronto Healing Abutment

- MU 10VI** Toronto Healing Abutment H4.5mm

DMRP120S Standard Hexagonal Driver Ø 1.20

toronto prosthetics

Pilastrini Temporanei Toronto - Titanio Gr. 5

Toronto Temporary Abutments - Titanium Gr. 5

TTA 1000 Antirotation Hex Temporary

TT 1000 Rotating Temporary

VIPMU 00 Vite di Ricambio - Spare Screw

DMRP120S Standard Hexagonal Driver Ø 1.20

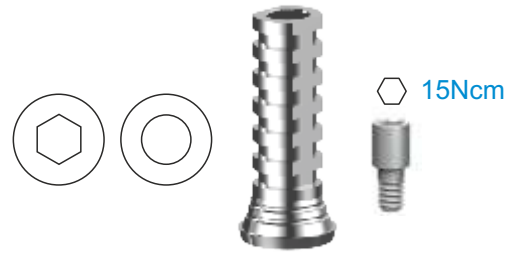

Pilastrini Toronto Calcinabili

Castable Toronto Abutments

TCA 1000 Toronto Castable Abutment - Antirotation Hex

TC 1000 Toronto Castable Abutment - Rotating

VIPMU 00 Vite di Ricambio - Spare Screw

DMRP120S Standard Hexagonal Driver Ø 1.20

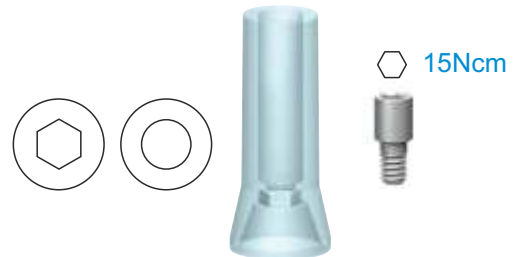

Pilastro Toronto in Cromo Cobalto

CoCr Toronto Abutment

TTCR 1000 Toronto CoCr Abutment - Rotating

VIPMU 00 Vite di Ricambio - Spare Screw

DMRP120S Standard Hexagonal Driver Ø 1.20

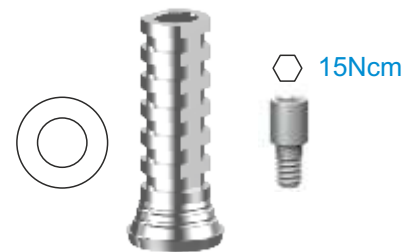

Analoghi Toronto per Laboratorio - Titanio Gr. 5

Laboratory Toronto Analogs - Titanium Gr. 5

MU 10ANA Antirotation Hex Toronto Analog

MU 10AN Rotating Toronto Analog

VIPA00 Vite di Ricambio - Spare Screw

DMRP120S Standard Hexagonal Driver Ø 1.20



Transfer Toronto Rotante - Titanio Gr. 5

Rotating Toronto Impression Coping - Titanium Gr. 5

MU 10TRA Antirotation Hex Toronto Impression Coping



MU 10TR Rotating Toronto Impression Coping

VIPMUTR Vite lunga di Ricambio - Long Spare Screw

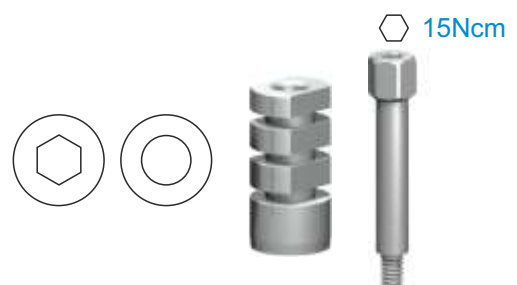
DMRP120S Standard Hexagonal Driver Ø 1.20



Transfer per impronta Digitale - Titanio Gr. 5
Scan Abutment - Titanium Gr. 5

15Ncm  

MU10SA Standard Gingival Profile Ø 4.5

VIPMU 00 Vite di Ricambio - Spare Screw
DMRP120S Standard Hexagonal Driver Ø 1.20

Analogo CAD da Laboratorio con Vite - Titanio Gr. 5
Laboratory CAD Analog with Screw - Titanium Gr. 5



MU10AN3D Con vite ritentiva per modelli stampati



Link Base per Incollaggio Antirotazione - Titanio Gr. 5
Antirotation Bonding Technique Base Link - Titanium Gr. 5

15Ncm  

MU10LK Gingival Profile **H 1mm** - Antirotation Hex

VIPAMU 00 Vite di Ricambio - Spare Screw
DMRP120S Standard Hexagonal Driver Ø 1.20



Vite protesica Toronto per canale angolato - Titanio Gr. 5
Prosthetic screw for angled hole - Titanium Gr. 5

15Ncm  

VPMU 00AI Vite Standard per canale angolato - STANDARD

MDT6DS Manual Torque Driver for angled hole
DCT6DS RA Contr-angle Torque Driver for angled hole

Vite protesica Toronto per canale angolato - Titanio Gr. 5
Prosthetic screw for angled hole - Titanium Gr. 5

15Ncm  

VPMU 00AITL Vite Lunga + 2mm per canale angolato - LONG

MDT6DS Manual Torque Driver for angled hole
DCT6DS RA Contr-angle Torque Driver for angled hole

oneabutment octa prosthetics

Oneabutment Octa 3.8 - Titanio Gr. 5

Oneabutment Octa 3.8 - Titanium Gr. 5

IPBO 381	Oneabutment Transgengivale H1.5 mm
IPBO 382	Oneabutment Transgengivale H2.5 mm
IPBO 383	Oneabutment Transgengivale H3.5 mm
IPBO 384	Oneabutment Transgengivale H4.5 mm
IPBO 385	Oneabutment Transgengivale H5.5 mm

DCOCT1 Prolunga da Cricchetto Corta per serraggio Octa



Oneabutment Octa 4.8 - Titanio Gr. 5

Oneabutment Octa 4.8 - Titanium Gr. 5

IPBO 481	Oneabutment Transgengivale H1.5 mm
IPBO 482	Oneabutment Transgengivale H2.5 mm
IPBO 483	Oneabutment Transgengivale H3.5 mm
IPBO 484	Oneabutment Transgengivale H4.5 mm
IPBO 485	Oneabutment Transgengivale H5.5 mm

DCOCT1 Prolunga da Cricchetto Corta per serraggio Octa



Pilastro di Guarigione Octa - Titanio Gr. 5

Octa Healing Abutment - Titanium Gr. 5

EPHAO 384	Healing Cap Octa \varnothing 3.8 mm
EPHAO 484	Healing Cap Octa \varnothing 4.8 mm

DMRP120S Standard Hexagonal Driver \varnothing 1.20



Transfer per impronta Digitale - Titanio Gr. 5

Scan Abutment - Titanium Gr. 5

EPSAO 38	Scan Abutment Octa \varnothing 3.8 mm e \varnothing 4.8 mm
-----------------	----------------------------------------------------------------

EPVO Vite di Ricambio - Spare Screw
DMRP120S Standard Hexagonal Driver \varnothing 1.20



Transfer per impronta Pick Up - Titanio Gr. 5

Pick Up Impression Coping - Titanium Gr. 5

EPIAO 38	Impression Coping Octa \varnothing 3.8 mm e \varnothing 4.8 mm
-----------------	--------------------------------------------------------------------

EPVLO Vite di Ricambio - Spare Screw
DMRP120S Standard Hexagonal Driver \varnothing 1.20



oneabutment octa prosthetics



Analogo Digitale Octa per Laboratorio - Titanio Gr. 5
Laboratory Octa Digital Analog - Titanium Gr. 5

EPBALO 38DS Analogo Digitale Octa Ø 3.8 mm

EPBALO 48DS Analogo Digitale Octa Ø 4.8 mm

32Ncm

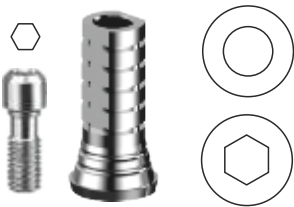

Pilastro Temporaneo Octa - Titanio Gr. 5
Octa Temporary Abutment - Titanium Gr. 5

EPTRO 38 Rotating Temporary Octa Ø 3.8 mm

EPTRO 48 Rotating Temporary Octa Ø 4.8 mm

EPTAO 38 Antirotation Hex Temporary Octa Ø 3.8 mm

EPTAO 48 Antirotation Hex Temporary Octa Ø 4.8 mm

EPVO Vite di Ricambio - Spare Screw

DMRP120S Standard Hexagonal Driver Ø 1.20

32Ncm

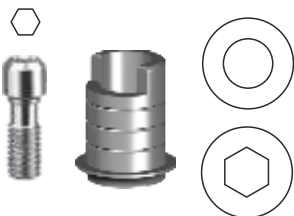

Link Base Octa per Incollaggio Basso - Titanio Gr. 5
Short Bonding Technique Octa Base Link - Titanium Gr. 5

EPTRO 380 DS Rotating TiBase Octa Ø 3.8 mm - 0mm

EPTRO 480 DS Rotating TiBase Octa Ø 4.8 mm - 0mm

EPTAO 380 DS Antirotation Hex TiBase Octa Ø 3.8 mm - 0mm

EPTAO 480 DS Antirotation Hex TiBase Octa Ø 4.8 mm - 0mm

EPVO Vite di Ricambio - Spare Screw

EPVLOT6DS Vite per Canale Angolato - Angled Hole Screw

DMRP120S Standard Hexagonal Driver Ø 1.20

32Ncm

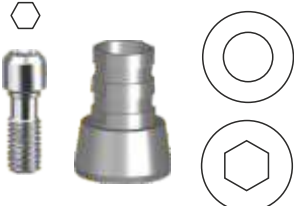

Link Base Octa per Incollaggio Alto - Titanio Gr. 5
High Bonding Technique Octa Base Link - Titanium Gr. 5

EPTRO 38 DS Rotating TiBase Octa Ø 3.8 mm - 3mm

EPTRO 48 DS Rotating TiBase Octa Ø 4.8 mm - 3mm

EPTAO 38 DS Antirotation Hex TiBase Octa Ø 3.8 mm - 3mm

EPTAO 48 DS Antirotation Hex TiBase Octa Ø 4.8 mm - 3mm

EPVO Vite di Ricambio - Spare Screw

EPVLOT6DS Vite per Canale Angolato - Angled Hole Screw

DMRP120S Standard Hexagonal Driver Ø 1.20

CONE abutment prosthetics

Moncone CONE Angolato - Titanio Gr. 5
Angled CONE Abutment - Titanium Gr. 5

- IPBCON 7L2** 7.5° Angled CONE Abutment H2 mm **Long 6 mm**
- IPBCON 15L2** 15° Angled CONE Abutment H2 mm **Long 6 mm**
- IPBCON 22L3** 22.5° Angled CONE Abutment H3 mm **Long 6 mm**
- IPBCON 30L3** 30° Angled CONE Abutment H3 mm **Long 6 mm**

VIPA00 Vite di Ricambio - Spare Screw
DMRP120S Standard Hexagonal Driver Ø 1.20



Moncone CONE Diritto - Titanio Gr. 5
Straight CONE Abutment - Titanium Gr. 5

- IPBCON 0S1** Straight CONE Abutment H1.5 mm **Short 4 mm**
- IPBCON 0S1** Straight CONE Abutment H1.5 mm **Long 6 mm**

VIPA00 Vite di Ricambio - Spare Screw
DMRP120S Standard Hexagonal Driver Ø 1.20



Cappette CONE - Titanio Gr. 5
CONE Caps - Titanium Gr. 5

- CTCON RS-S** CONE Welding Cap **Short 4 mm** - Rotating
- CTCON RL-S** CONE Welding Cap **Long 6 mm** - Rotating
- CTCON RS** CONE Gluing Cap **Short 4 mm** - Rotating
- CTCON AS** CONE Gluing Cap **Short 4 mm** - Anti-rotation
- CTCON RL** CONE Gluing Cap **Long 6 mm** - Rotating
- CTCON AL** CONE Gluing Cap **Long 6 mm** - Anti-rotation



Transfer CONE Digitale e Cappetta CONE - PEEK
Scan Abutment and CONE Cap - PEEK

- IACON S** Scan Abutment/Peek Cap CONE **Short 4 mm**
- IACON L** Scan Abutment/Peek Cap CONE **Long 6 mm**

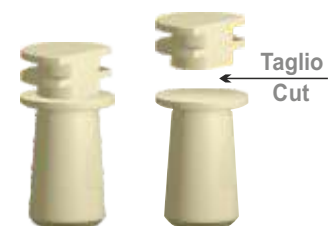

Analogo Digitale CONE per Laboratorio - Titanio Gr. 5
Laboratory CONE Digital Analog - Titanium Gr. 5

- ALCON S** Digital Analog CONE **Short 4 mm**
- ALCON L** Digital Analog CONE **Long 6 mm**





EXTERNAL HEXAGON

4.1 REGULAR CONNECTION

CYLINDRICAL
SHAPE



EC

EC 34

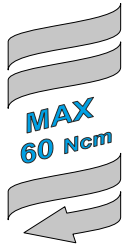

CYLINDRICAL SHAPE External Hexagon

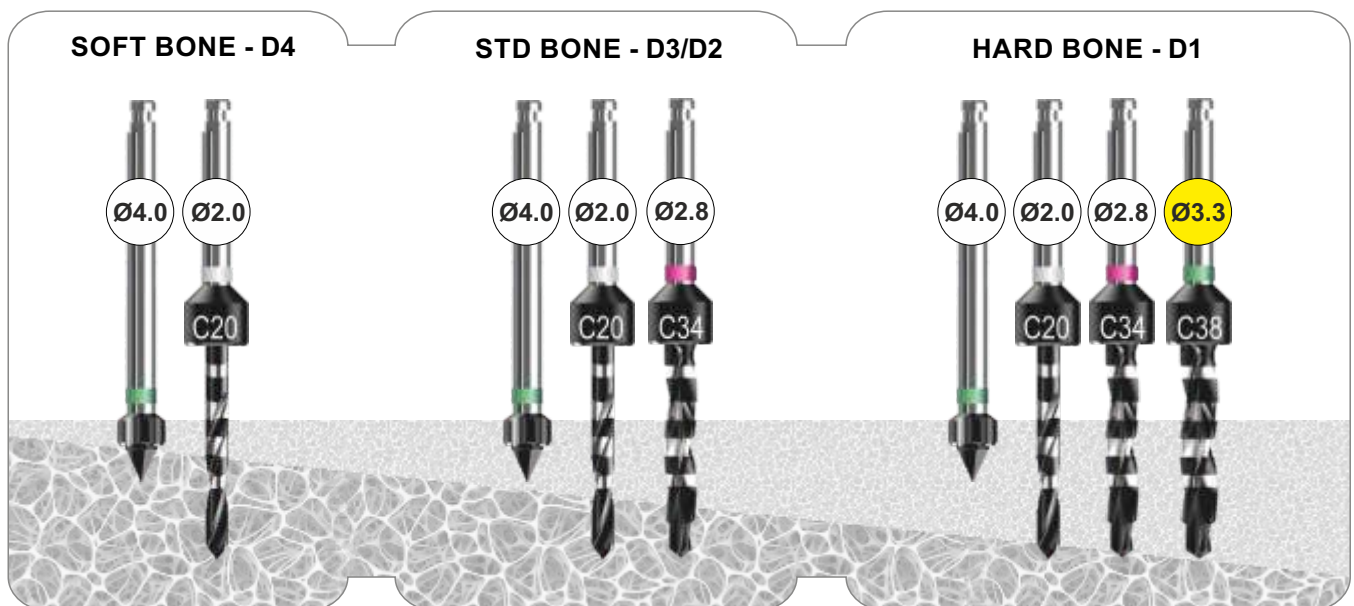
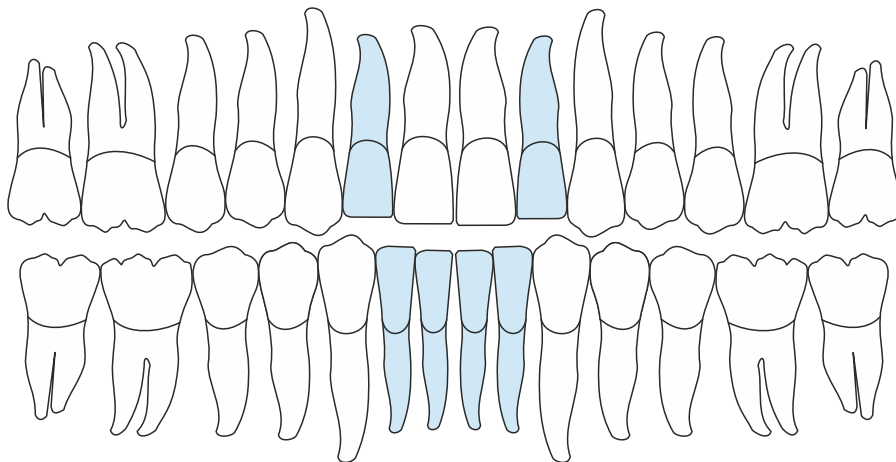
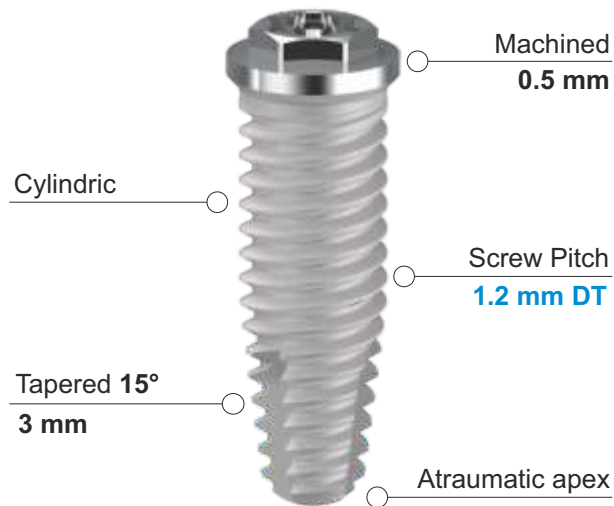

Velocità di rotazione frese consigliata 500 - 800 rpm

Recommended milling burs rotation speed 500 - 800 rpm

EC 38



CYLINDRICAL SHAPE External Hexagon

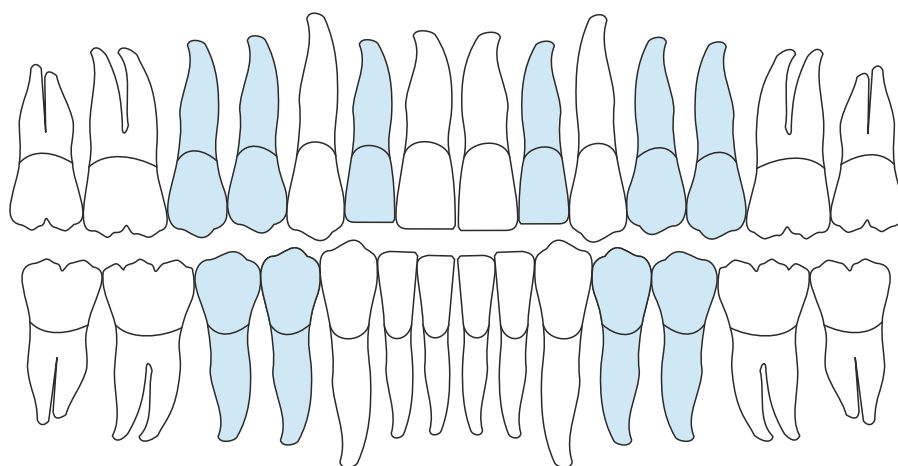
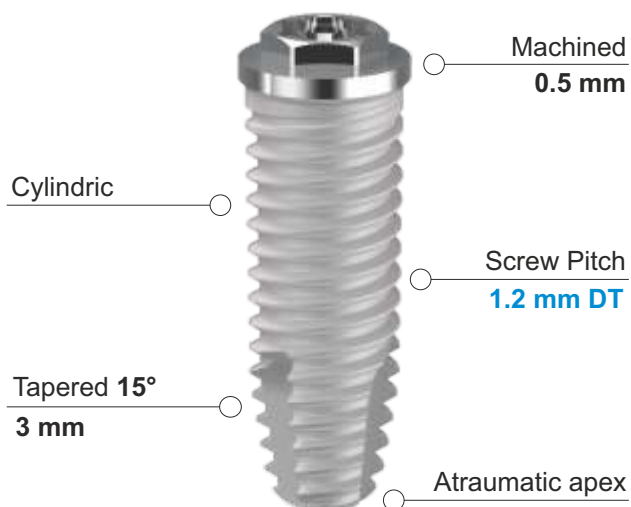

SOFT BONE - D4



STD BONE - D3/D2



HARD BONE - D1

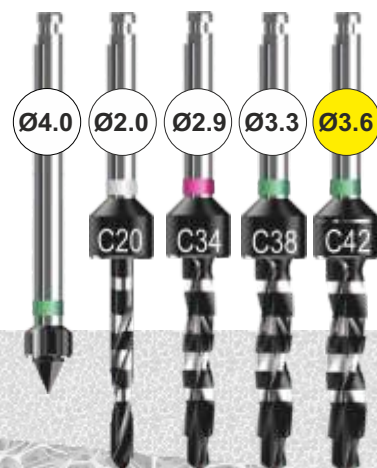

Velocità di rotazione frese consigliata 500 - 800 rpm

Recommended milling burs rotation speed 500 - 800 rpm

EC 42

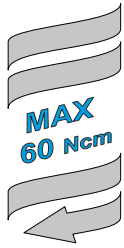

CYLINDRICAL SHAPE External Hexagon

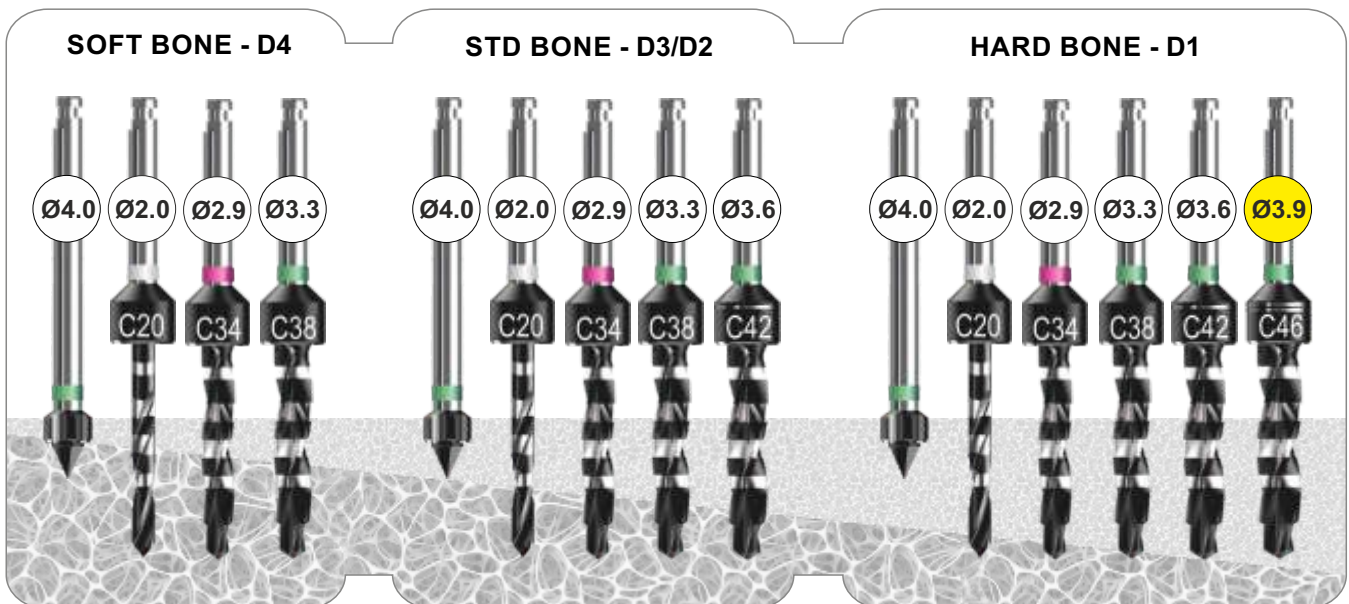
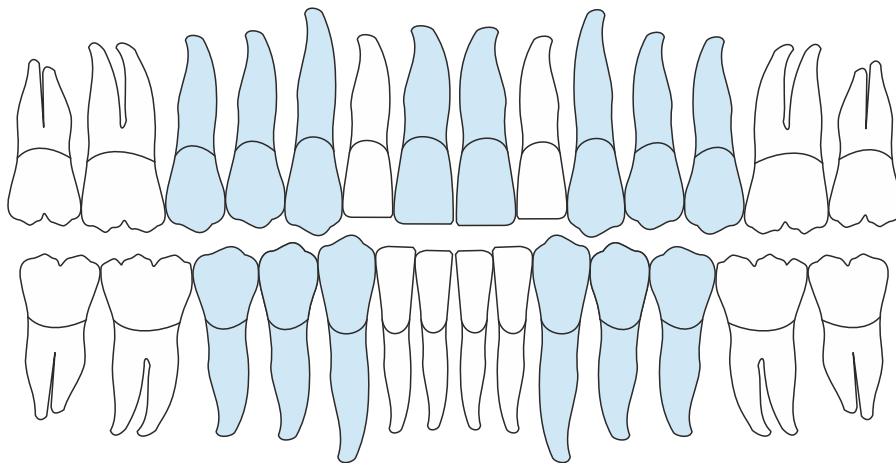
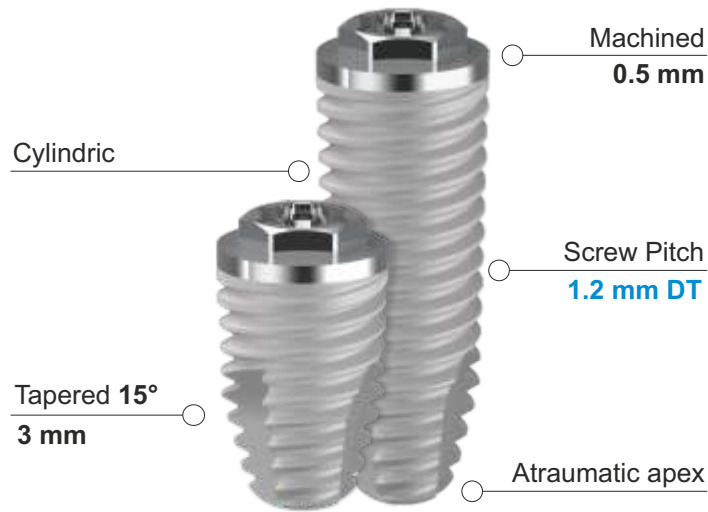

Velocità di rotazione frese consigliata 500 - 800 rpm

Recommended milling burs rotation speed 500 - 800 rpm

EC 50

CYLINDRICAL SHAPE External Hexagon

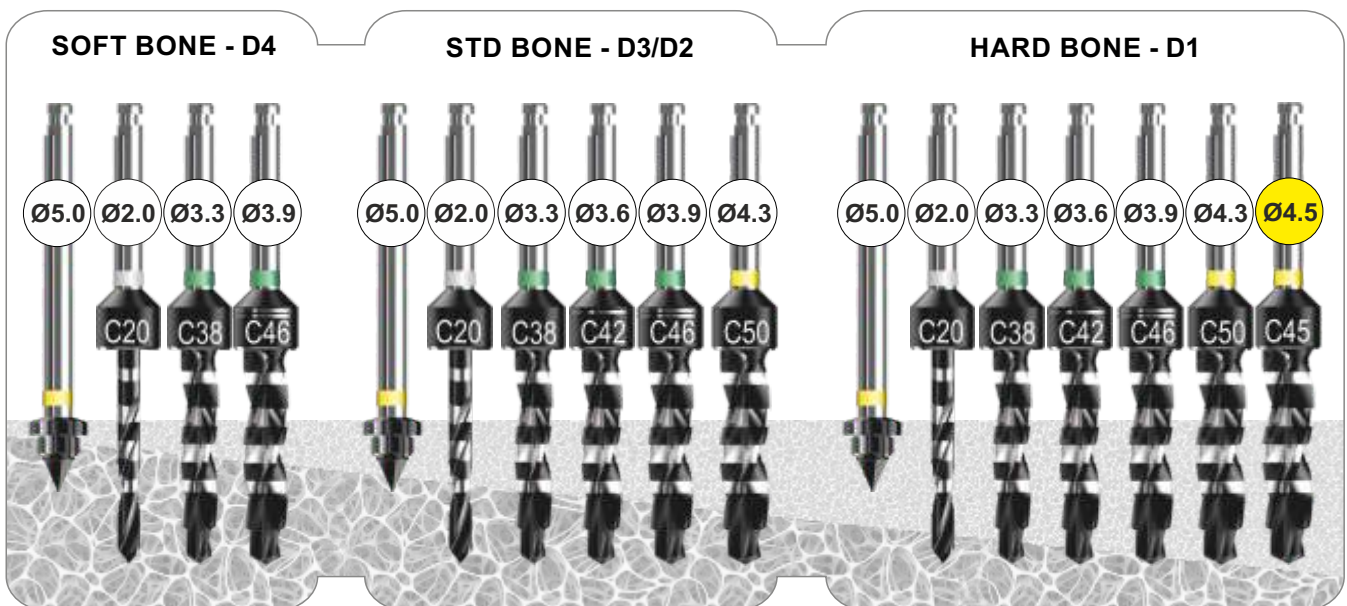
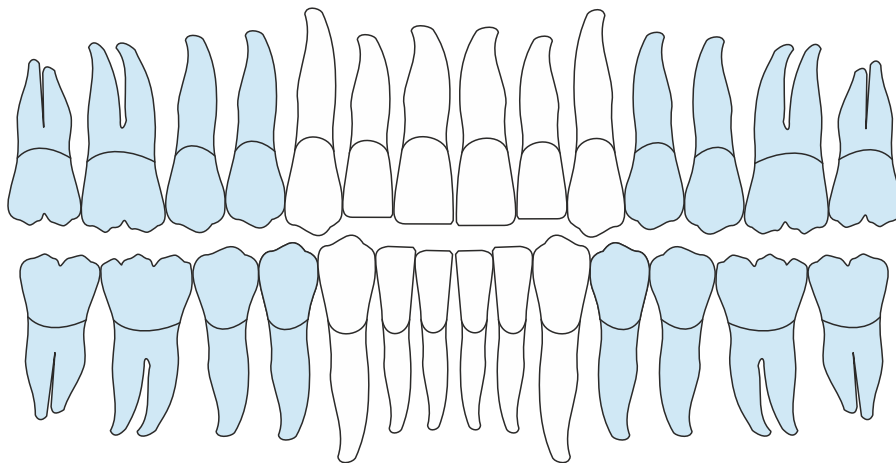
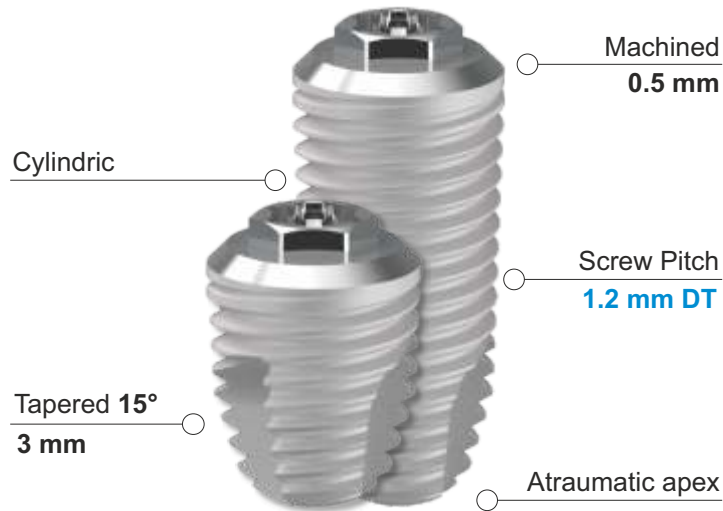
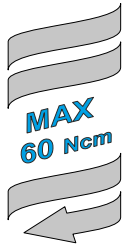

Velocità di rotazione frese consigliata 500 - 800 rpm

Recommended milling burs rotation speed 500 - 800 rpm

3.4 Full Treatment - With Moulder



CODE	IMPLANT	LENGTH	PLATFORM	APEX
EC 3408	Ø 3.4	8.5 mm	Ø 4.1	Ø 2.0
EC 3410	Ø 3.4	10 mm	Ø 4.1	Ø 2.0
EC 3411	Ø 3.4	11.5 mm	Ø 4.1	Ø 2.0
EC 3413	Ø 3.4	13 mm	Ø 4.1	Ø 2.0

3.8 - 4.2 Full Treatment - With Moulder



CODE	IMPLANT	LENGTH	PLATFORM	APEX
EC 3808	Ø 3.8	8.5 mm	Ø 4.1	Ø 2.2
EC 3810	Ø 3.8	10 mm	Ø 4.1	Ø 2.2
EC 3811	Ø 3.8	11.5 mm	Ø 4.1	Ø 2.2
EC 3813	Ø 3.8	13 mm	Ø 4.1	Ø 2.2
EC 3815	Ø 3.8	15 mm	Ø 4.1	Ø 2.2
EC 4206	Ø 4.2	6,0 mm	Ø 4.1	Ø 2.5
EC 4208	Ø 4.2	8.5 mm	Ø 4.1	Ø 2.5
EC 4210	Ø 4.2	10 mm	Ø 4.1	Ø 2.5
EC 4211	Ø 4.2	11.5 mm	Ø 4.1	Ø 2.5
EC 4213	Ø 4.2	13 mm	Ø 4.1	Ø 2.5

5.0 Full Treatment - With Moulder



CODE	IMPLANT	LENGTH	PLATFORM	APEX
EC 5006	Ø 5.0	6.0 mm	Switch Ø 4.1	Ø 3.5
EC 5008	Ø 5.0	8.5 mm	Switch Ø 4.1	Ø 3.5
EC 5010	Ø 5.0	10 mm	Switch Ø 4.1	Ø 3.5
EC 5011	Ø 5.0	11.5 mm	Switch Ø 4.1	Ø 3.5
EC 5013	Ø 5.0	13 mm	Switch Ø 4.1	Ø 3.5

3.4 Half Treatment - With Moulder



CODE	IMPLANT	LENGTH	PLATFORM	APEX
EC 3408 HT	Ø 3.4	8.5 mm	Ø 4.1	Ø 2.0
EC 3410 HT	Ø 3.4	10 mm	Ø 4.1	Ø 2.0
EC 3411 HT	Ø 3.4	11.5 mm	Ø 4.1	Ø 2.0
EC 3413 HT	Ø 3.4	13 mm	Ø 4.1	Ø 2.0

4.2 Half Treatment - With Moulder



CODE	IMPLANT	LENGTH	PLATFORM	APEX
EC 4206 HT	Ø 4.2	6,0 mm	Ø 4.1	Ø 2.5
EC 4208 HT	Ø 4.2	8.5 mm	Ø 4.1	Ø 2.5
EC 4210 HT	Ø 4.2	10 mm	Ø 4.1	Ø 2.5
EC 4211 HT	Ø 4.2	11.5 mm	Ø 4.1	Ø 2.5
EC 4213 HT	Ø 4.2	13 mm	Ø 4.1	Ø 2.5

5.0 Half Treatment - With Moulder



CODE	IMPLANT	LENGTH	PLATFORM	APEX
EC 5006 HT	Ø 5.0	6.0 mm	Switch Ø 4.1	Ø 3.5
EC 5008 HT	Ø 5.0	8.5 mm	Switch Ø 4.1	Ø 3.5
EC 5010 HT	Ø 5.0	10 mm	Switch Ø 4.1	Ø 3.5
EC 5011 HT	Ø 5.0	11.5 mm	Switch Ø 4.1	Ø 3.5
EC 5013 HT	Ø 5.0	13 mm	Switch Ø 4.1	Ø 3.5



EXTERNAL HEXAGON

4.1 REGULAR CONNECTION

CONICAL
SHAPE



EK

EK 38



CONICAL SHAPE
External Hexagon

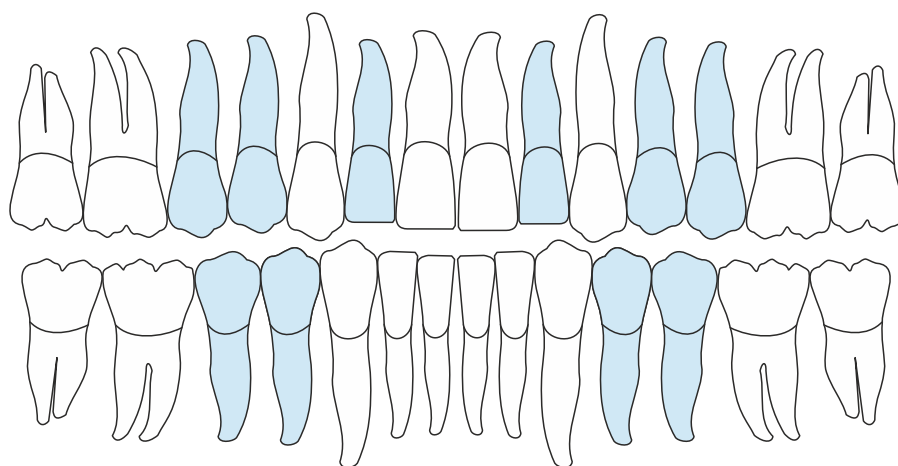
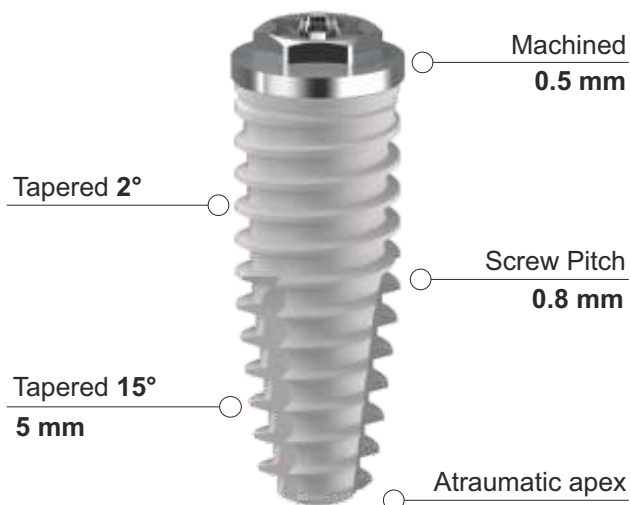

SOFT BONE - D4



STD BONE - D3/D2



HARD BONE - D1

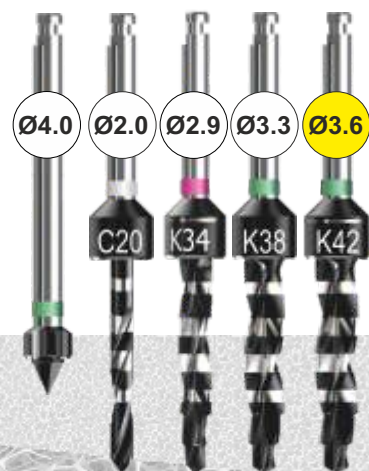

Velocità di rotazione frese consigliata 500 - 800 rpm

Recommended milling burs rotation speed 500 - 800 rpm

EK 46

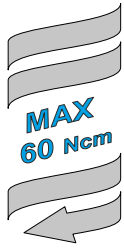

CONICAL SHAPE
External Hexagon

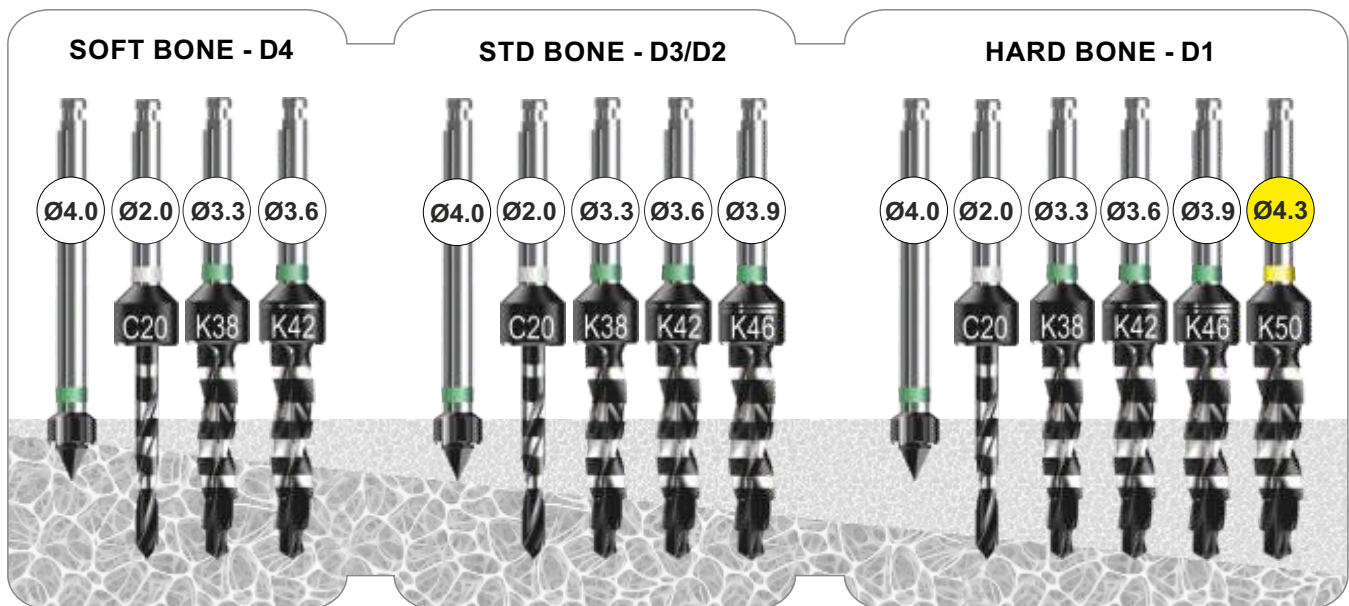
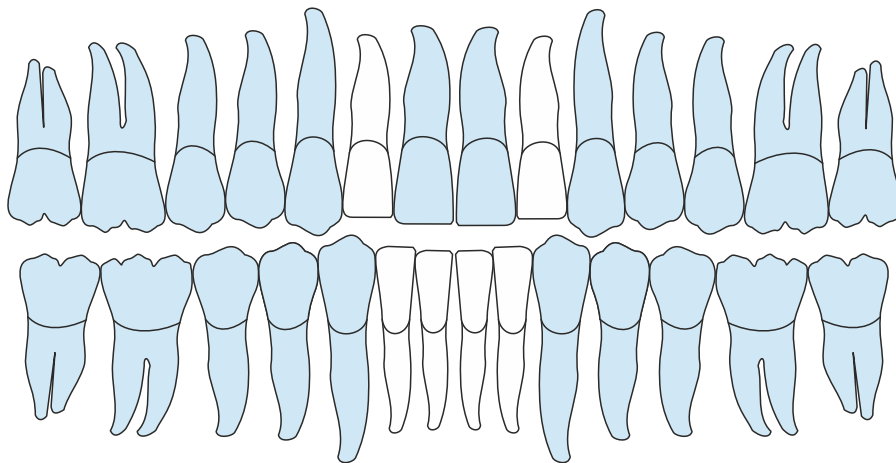
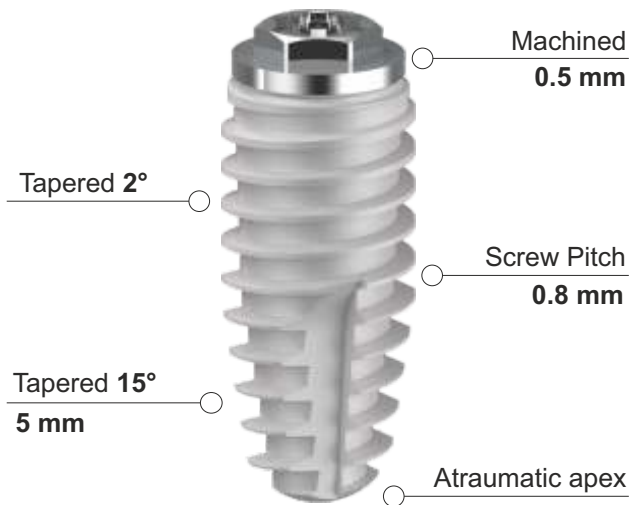

Velocità di rotazione frese consigliata 500 - 800 rpm

Recommended milling burs rotation speed 500 - 800 rpm

3.8 Full Treatment - With Moulder



CODE	IMPLANT	LENGTH	PLATFORM	APEX
EK 3808	Ø 3.8	8.5 mm	Ø 4.1	Ø 1.9
EK 3810	Ø 3.8	10 mm	Ø 4.1	Ø 1.9
EK 3811	Ø 3.8	11.5 mm	Ø 4.1	Ø 1.9
EK 3813	Ø 3.8	13 mm	Ø 4.1	Ø 1.9
EK 3815	Ø 3.8	15 mm	Ø 4.1	Ø 1.9

4.6 Full Treatment - With Moulder



CODE	IMPLANT	LENGTH	PLATFORM	APEX
EK 4608	Ø 4.6	8.5 mm	Ø 4.1	Ø 2.5
EK 4610	Ø 4.6	10 mm	Ø 4.1	Ø 2.5
EK 4611	Ø 4.6	11.5 mm	Ø 4.1	Ø 2.5
EK 4613	Ø 4.6	13 mm	Ø 4.1	Ø 2.5
EK 4615	Ø 4.6	15 mm	Ø 4.1	Ø 2.5



EXTERNAL HEXAGON

4.1 REGULAR CONNECTION

UNIVERSAL PROSTHETICS



4.1 universal prosthetics

20Ncm 



Pilastro di Guarigione - Titanio Gr. 5 - Anodizzato
Healing Abutment - Titanium Gr. 5 - Anodized

EP 4HA2 H 2 mm - Standard Gingival Profile
EP 4HA4 H 4 mm - Standard Gingival Profile
EP 4HA6 H 6 mm - Standard Gingival Profile
DM 1/2 Standard Hexagonal Driver

20Ncm 



Pilastro di Guarigione Allargato - Titanio Gr. 5 - Anodizzato
Large Healing Abutment - Titanium Gr. 5 - Anodized

EP 5HA3 H 3 mm - Large Gingival Profile
EP 5HA5 H 5 mm - Large Gingival Profile
DM 1/2 Standard Hexagonal Driver



Analogo per Laboratorio - Titanio Gr. 5 - Anodizzato
Laboratory Analog - Titanium Gr. 5 - Anodized

EP 4AL H 12 mm - Universal Shape

32Ncm 



Moncone Calcinabile - Acrilico
Castable Abutment - Acrylic

EP 4CA Antirotaion Hex - Standard Gingival Profile
EP 4CR Rotating - Standard Gingival Profile
EP VITG Vite di Ricambio Gold - Gold Spare Screw
DM 1/2 Standard Hexagonal Driver

32Ncm 



Moncone Titanio - Titanio Gr. 5 - PVD TiN
Titanium Abutment - Titanium Gr. 5 - PVD TiN

EP 4ST2 0° - Straight - Standard Gingival Profile
EP 5ST3 0° - Straight - **Large Gingival Profile**
EP VITG Vite di Ricambio Gold - Gold Spare Screw
DM 1/2 Standard Hexagonal Driver

4.1 universal prosthetics

Moncone Titanio - Titanio Gr. 5 - PVD TiN

Titanium Abutment - Titanio Gr. 5 - PVD TiN

EP 4AT15 15° - Angled - Standard Gingival Profile

EP 4AT25 25° - Angled - Standard Gingival Profile

EP 5AT15 15° - Angled - **Large Gingival Profile**

EP VITG Vite di Ricambio Gold - Gold Spare Screw

DM 1/2 [Standard Hexagonal Driver](#)



Moncone Ucla Oro - Base Oro/Platino/Iridio

Ucla Gold Abutment - Gold/Platinum/Iridium Base

EP 4GA Antirotation Hex - Standard Gingival Profile

EP 5GA Antirotation Hex - **Large Gingival Profile**

EP VITG Vite di Ricambio Gold - Gold Spare Screw

DM 1/2 [Standard Hexagonal Driver](#)



Moncone Provvisorio Estetico - PEEK Medicaale

Aesthetic Temporary Abutment - Medical PEEK

EP 4PA Antirotation Hex - Standard Gingival Profile

EP VITG Vite di Ricambio Gold - Gold Spare Screw

DM 1/2 [Standard Hexagonal Driver](#)



Pilastro Temporaneo - Titanio Gr. 5

Temporary Abutment - Titanium Gr. 5

EP 4TA Antirotation Hex - Standard Gingival Profile

EP 4TR Rotating - Standard Gingival Profile

EP VITG Vite di Ricambio Gold - Gold Spare Screw

DM 1/2 [Standard Hexagonal Driver](#)



Link per Incollaggio TiB - Titanio Gr. 5

Bonding Technique Link TiB - Titanium Gr. 5

EP 4STB Link in Titanio Antirotazione - Compatibile TiB

EP VIT Vite di Ricambio - Spare Screw

DM 1/2 [Standard Hexagonal Driver](#)



4.1 universal prosthetics

32Ncm 



Moncone Estetico - Zirconia

Esthetic Abutment - Zirconium

EP 4SZ 0° - Straight - Standard Gingival Profile

EP 4AZ15 15° - Angled - Standard Gingival Profile

EP VIT Vite di Ricambio - Spare Screw

DM 1/2 Standard Hexagonal Driver

25Ncm 



Transfer per Impronta Pick Up - Titanio Gr. 5

Pick Up Impression Coping - Titanium Gr. 5

EP X40 H 12mm - Standard Gingival Profile

EP VITL Vite di Ricambio - Spare Screw

DM 1/2 Standard Hexagonal Driver

32Ncm 



Pilastro a Sfera per Overdenture - Titanio Gr. 5 - PVD TiN

Overdenture Ball Abutment - Titanium Gr. 5 - PVD TiN

EP 4BA1 H 1 mm - Standard Gingival Profile - NORMO

EP 4BA2 H 2 mm - Standard Gingival Profile - NORMO

EP 4BA3 H 3 mm - Standard Gingival Profile - NORMO

EP 4BA4 H 4 mm - Standard Gingival Profile - NORMO

EP 4BA6 H 6 mm - Standard Gingival Profile - NORMO

DM 1/2 Standard Hexagonal Driver Ø 1.27

32Ncm 



Kit Pilastro Equator per Overdenture - Titanio Gr. 5 - PVD

Overdenture Equator Abutment Kit - Titanium Gr. 5 - PVD

EP 4EQ2 H 2 mm - Narrow Gingival Profile

EP 4EQ3 H 3 mm - Narrow Gingival Profile

EP 4EQ4 H 4 mm - Narrow Gingival Profile

EP 4EQ5 H 5 mm - Narrow Gingival Profile

EP 4EQ6 H 6 mm - Narrow Gingival Profile

DM EQ Squared Equator Driver

toronto 4.1 universal prosthetics

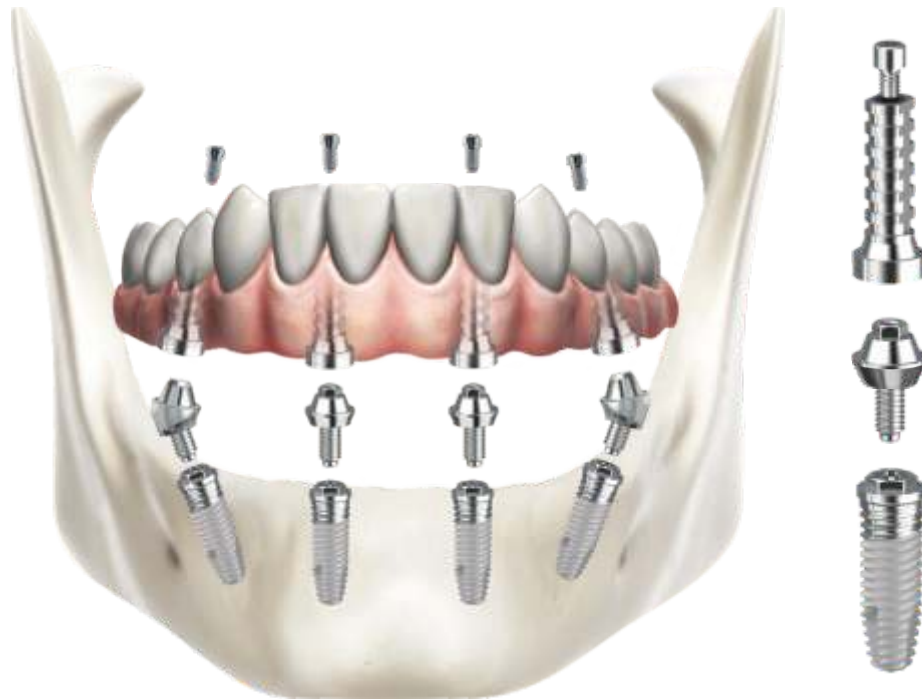

Pilastro Toronto 4 Diritto - Titanio Gr. 5

Toronto 4 Straight Abutment - Titanium Gr. 5

EP MS2 H 2 mm - Standard Gingival Profile

EP MS3 H 3 mm - Standard Gingival Profile

DCDM Toronto Straight Abutment Driver



Pilastro Toronto 4 Angolato - Titanio Gr. 5

Toronto 4 Angled Abutment - Titanium Gr. 5

EP MA172 17° - H 2 mm - Standard Gingival Profile

EP MA173 17° - H 3 mm - Standard Gingival Profile

EP MA303 30° - H 3 mm - Standard Gingival Profile

EP MA304 30° - H 4 mm - Standard Gingival Profile

EP VITMA Vite di Ricambio Toronto - Toronto Spare Screw

DMX 1/2 Standard Torx Driver



Pilastro Temporaneo Toronto - Titanio Gr. 5

Toronto Temporary Abutment - Titanium Gr. 5

EP MT Rotating - Bonding Technique - Incollaggio Passivo

EP MTS Rotating - Welding Technique - Saldatura Intraorale

EP MV Vite di Ricambio Toronto - Toronto Spare Screw

DMX 1/2 Standard Torx Driver



toronto 4.1 universal prosthetics



Pilastro Calcinabile Toronto - Acrilico

Toronto Castable Abutment - Acrylic

EP MC Rotating - Standard Gingival Profile

EP MV Vite di Ricambio Toronto - Toronto Spare Screw

DMX 1/2 Standard Torx Driver



Transfer Toronto - Titanio Gr. 5

Toronto Impression Coping - Titanium Gr. 5

EP MI Rotating - Standard Gingival Profile

EP MVL Vite di Ricambio Toronto - Toronto Spare Screw

DMX 1/2 Standard Torx Driver



Analogo Toronto - Titanio Gr. 5

Toronto Analog - Titanium Gr. 5

EP MAL2DS-V H 10 mm - Universal Shape



Pilastro di Guarigione Toronto

Toronto Healing Abutment

EP MHA H 4 mm - Standard Gingival Profile Titanium Gr5

EP MHA6 H 6 mm - Large Gingival Profile Titanium Gr5

DMX 1/2 Standard Torx Driver

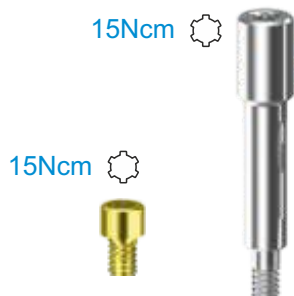

Viti di Ricambio Toronto - Titanio Gr. 5

Toronto Spare Screws - Titanium Gr. 5

EP MV Prosthetic Spare Screw

EP MVL Impression Spare Screw

DMX 1/2 Standard Torx Driver

Transfer per Impronta Digitale - Titanio Gr. 5 + MS

Scan Abutment - Titanium Gr. 5 + Micro Sandblasting

NSPSB41K Antirotation Hex - **Standard** Gingival Profile

ACT VP Vite di Ricambio - Spare Screw

DMX 1/2 Standard Torque Driver



Link Base per Incollaggio - Titanio Gr. 5

Bonding Technique Base Link - Titanium Gr. 5

NSPLK41K Gingival Profile **H 1mm** - Antirotation Hex

NSPLKR41K Gingival Profile **H 1mm** - Rotating

ACT VP Vite di Ricambio - Spare Screw

DMX 1/2 Standard Torx Driver

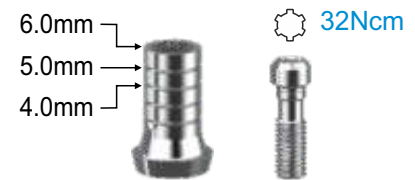

Adjustable in 3 heights

Analogo CAD da Laboratorio con Vite - Titanio Gr. 5

Laboratory CAD Analog with Screw - Titanium Gr. 5

NSPAN3D41K Antirotation Hex - Ø 4.1 Universal Shape

EP MAL2 DS Universal Toronto CAD Analog



Transfer Toronto per Impronta Digitale - Titanio Gr. 5

Toronto Scan Abutment - Titanium Gr. 5

EP MSA2 DS Rotating Scan Abutment - Transfer Digitale Rotante

EP MV Vite di Ricambio Toronto - Toronto Spare Screw

DMX 1/2 Standard Torx Driver



Link Base per Incollaggio - Titanio Gr. 5

Bonding Technique Base Link - Titanium Gr. 5

EP MT DS Rotating Bonding Technique - Incollaggio Passivo

EP MV Vite di Ricambio Toronto - Toronto Spare Screw

DMX 1/2 Standard Torx Driver

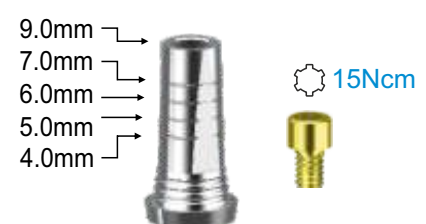

Adjustable in 5 heights



EXTERNAL HEXAGON SPEEDY MULTI PLATFORM

CYLINDRICAL
SHAPE



ES

ES 33



CYLINDRICAL SHAPE Narrow External Hexagon

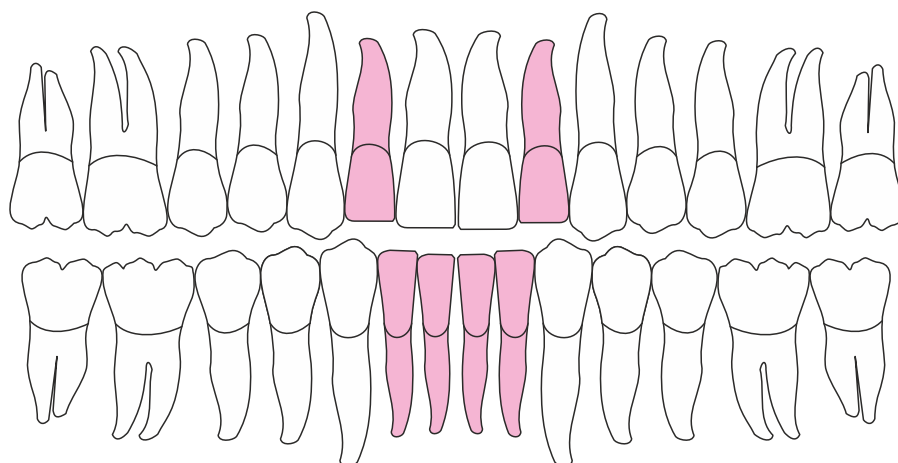
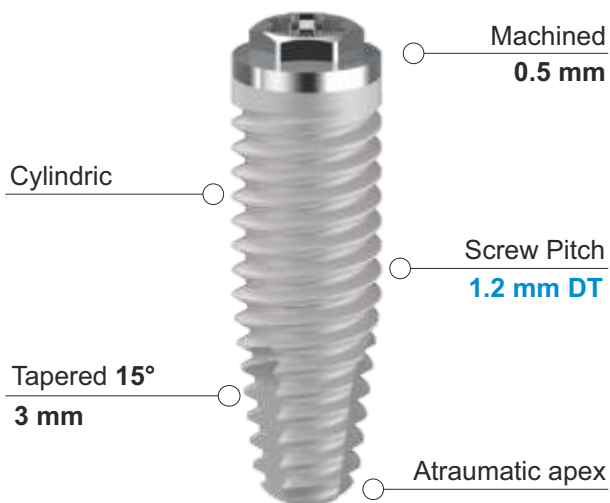

SOFT BONE - D4



STD BONE - D3/D2



HARD BONE - D1



Velocità di rotazione frese consigliata 500 - 800 rpm

Recommended milling burs rotation speed 500 - 800 rpm

3.3 Full Treatment - Mounterless



CODE	IMPLANT	LENGTH	PLATFORM	APEX
ES 3310	Ø 3.3	10 mm	Ø 3.5	Ø 2.0
ES 3311	Ø 3.3	11,5 mm	Ø 3.5	Ø 2.0
ES 3313	Ø 3.3	13 mm	Ø 3.5	Ø 2.0
ES 3315	Ø 3.3	15 mm	Ø 3.5	Ø 2.0

3.3 Half Treatment - Mounterless



CODE	IMPLANT	LENGTH	PLATFORM	APEX
ES 3310 HT	Ø 3.3	10 mm	Ø 3.5	Ø 2.0
ES 3311 HT	Ø 3.3	11,5 mm	Ø 3.5	Ø 2.0
ES 3313 HT	Ø 3.3	13 mm	Ø 3.5	Ø 2.0



3.5 narrow prosthetics

20Ncm 



Pilastro di Guarigione - Titanio Gr. 5 - Anodizzato

Healing Abutment - Titanium Gr. 5 - Anodized

SP 3HA3 H 3 mm - Narrow Gingival Profile

SP 3HA5 H 5 mm - Narrow Gingival Profile

DMX 1/2

[Toronto Abutment Torx Driver](#)



Analogo per Laboratorio - Titanio Gr. 5 - Anodizzato

Laboratory Analog - Titanium Gr. 5 - Anodized

SP 3AL H 12 mm - Narrow Shape

25Ncm 



Moncone Calcinabile - Acrilico

Castable Abutment - Acrylic

SP 3CA Antirotaion Hex - Narrow Gingival Profile

SP 3CR Rotating - Narrow Gingival Profile

SP VIT33 Vite di Ricambio - Spare Screw

DMX 1/2

[Toronto Abutment Torx Driver](#)

25Ncm 



Moncone Titanio - Titanio Gr. 5 - PVD TiN

Titanium Abutment - Titanium Gr. 5 - PVD TiN

SP 3ST 0° - Straight - Narrow Gingival Profile

SP VIT33 Vite di Ricambio - Spare Screw

DMX 1/2

[Toronto Abutment Torx Driver](#)

25Ncm 



Moncone Titanio - Titanio Gr. 5 - PVD TiN

Titanium Abutment - Titanium Gr. 5 - PVD TiN

SP 3AT15 15° - Angled - Narrow Gingival Profile

SP 3AT25 25° - Angled - Narrow Gingival Profile

SP VIT33 Vite di Ricambio - Spare Screw

DMX 1/2

[Toronto Abutment Torx Driver](#)

3.5 narrow prosthetics

Pilastro Temporaneo - Titanio Gr. 5

Temporary Abutment - Titanium Gr. 5

SP 3TA Antirotation Hex - Narrow Gingival Profile

SP 3TR Rotating - Narrow Gingival Profile

SP VIT33 Vite di Ricambio - Spare Screw

DMX 1/2 [Toronto Abutment Torx Driver](#)



Transfer per Impronta Pick Up - Titanio Gr. 5

Pick Up Impression Coping - Titanium Gr. 5

SP 3IA H 12mm - Narrow Gingival Profile

SP VITL33 Vite di Ricambio Lunga - Long Spare Screw

DMX 1/2 [Toronto Abutment Torx Driver](#)



ES 38



CYLINDRICAL SHAPE Regular External Hexagon

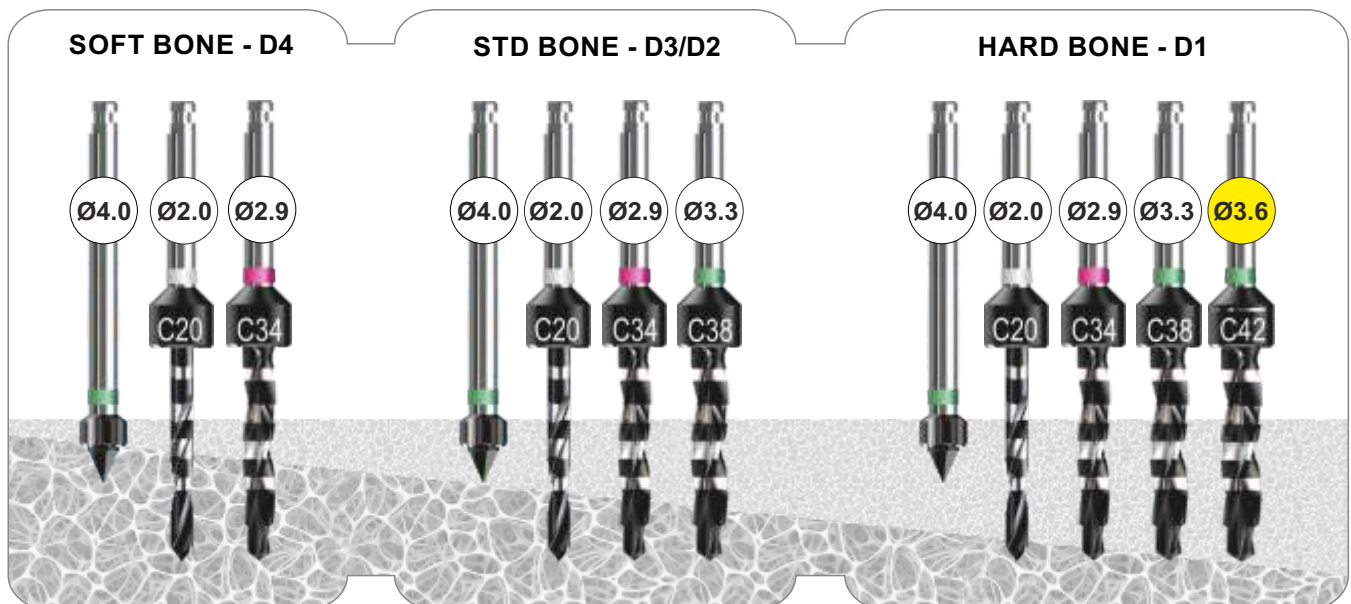
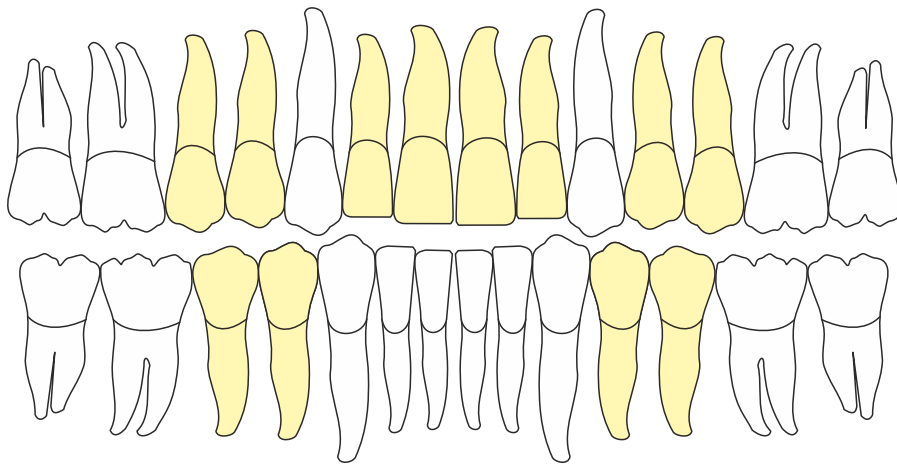
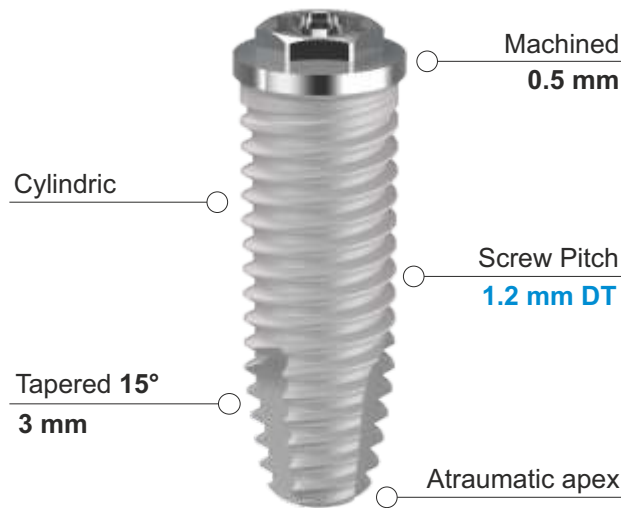

Velocità di rotazione frese consigliata 500 - 800 rpm

Recommended milling burs rotation speed 500 - 800 rpm

ES 40

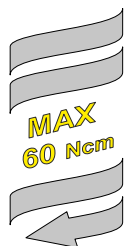

CYLINDRICAL SHAPE
Regular External Hexagon

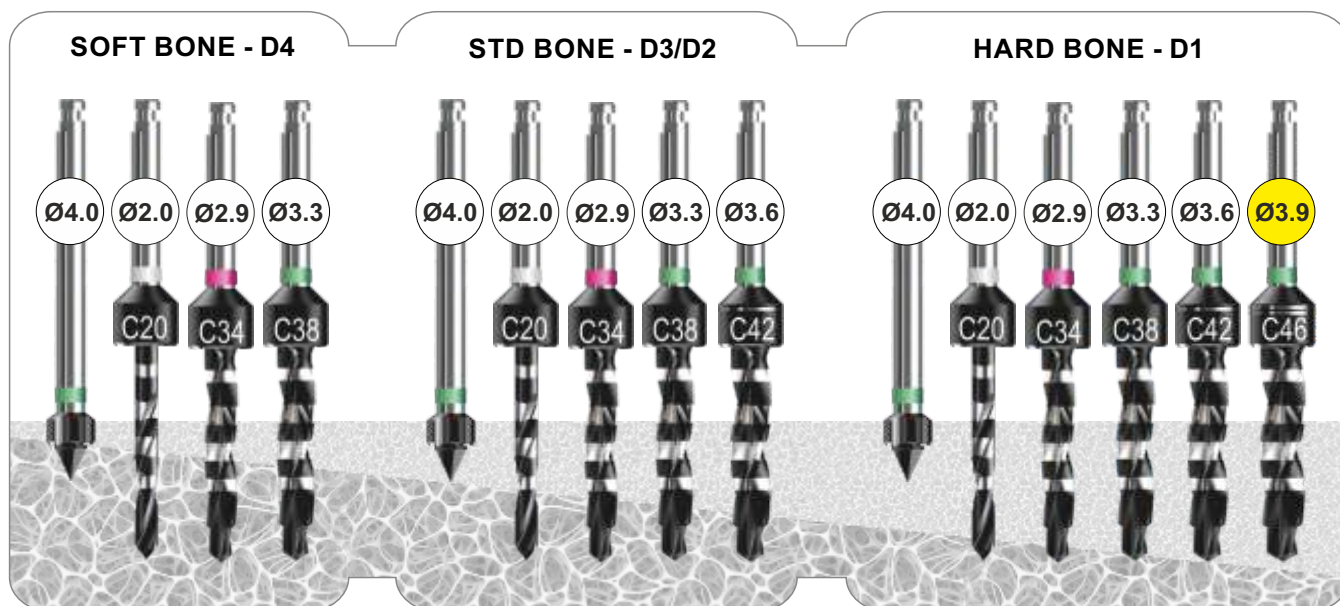
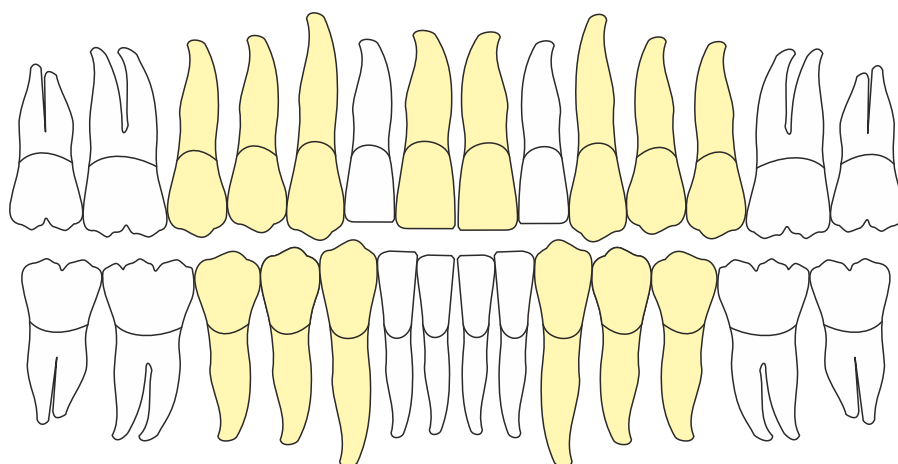
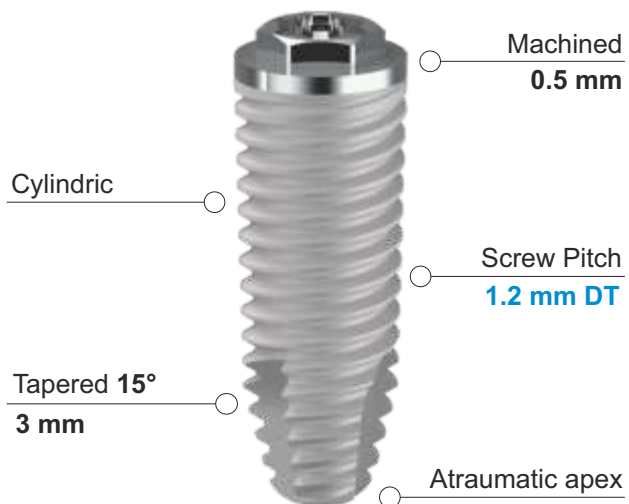

Velocità di rotazione frese consigliata 500 - 800 rpm

Recommended milling burs rotation speed 500 - 800 rpm

3.8 Full Treatment - Mounterless



CODE	IMPLANT	LENGTH	PLATFORM	APEX
ES 3808	Ø 3.8	8,5 mm	Ø 4.1	Ø 2.2
ES 3810	Ø 3.8	10 mm	Ø 4.1	Ø 2.2
ES 3811	Ø 3.8	11.5 mm	Ø 4.1	Ø 2.2
ES 3813	Ø 3.8	13 mm	Ø 4.1	Ø 2.2

4.0 Full Treatment - Mounterless



CODE	IMPLANT	LENGTH	PLATFORM	APEX
ES 4007	Ø 4.0	7 mm	Ø 4.1	Ø 2.5
ES 4008	Ø 4.0	8,5 mm	Ø 4.1	Ø 2.5
ES 4010	Ø 4.0	10 mm	Ø 4.1	Ø 2.5
ES 4011	Ø 4.0	11.5 mm	Ø 4.1	Ø 2.5
ES 4013	Ø 4.0	13 mm	Ø 4.1	Ø 2.5
ES 4015	Ø 4.0	15 mm	Ø 4.1	Ø 2.5
ES 4018	Ø 4.0	18 mm	Ø 4.1	Ø 2.5

4.0 Half Treatment - Mounterless



CODE	IMPLANT	LENGTH	PLATFORM	APEX
ES 4008 HT	Ø 4.0	8,5 mm	Ø 4.1	Ø 2.5
ES 4010 HT	Ø 4.0	10 mm	Ø 4.1	Ø 2.5
ES 4011 HT	Ø 4.0	11.5 mm	Ø 4.1	Ø 2.5
ES 4013 HT	Ø 4.0	13 mm	Ø 4.1	Ø 2.5
ES 4015 HT	Ø 4.0	15 mm	Ø 4.1	Ø 2.5
ES 4018 HT	Ø 4.0	18 mm	Ø 4.1	Ø 2.5

4.1 regular prosthetics

Pilastro di Guarigione - Titanio Gr. 5 - Anodizzato

Healing Abutment - Titanium Gr. 5 - Anodized

SP 4HA3 H 3 mm - Standard Gingival Profile

SP 4HA5 H 5 mm - Standard Gingival Profile

DMX 1/2 Standard Torx Driver

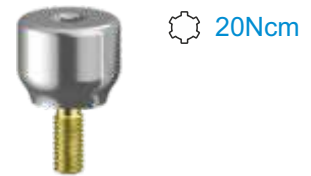

Analogo e Transfer per Impronta - Ti Gr. 5

Laboratory Analog and Pick Up Impression Coping - Ti Gr. 5

SP 4AL Laboratory Analog - Standard Shape

SP 4IA Pick Up Impression Coping

SP VITL40 Vite di Ricambio - Spare Screw

DMX 1/2 Standard Torx Driver

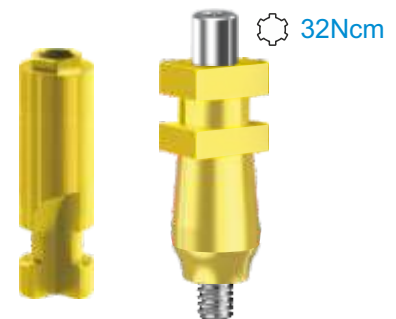

Moncone Calcinabile - Acrilico

Castable Abutment - Acrylic

SP 4CA Antirotation Hex - Standard Gingival Profile

SP 4CR Rotating - Standard Gingival Profile

SP VIT40 Vite di Ricambio - Spare Screw

DMX 1/2 Standard Torx Driver



Monconi in Titanio - Titanio Gr. 5 - PVD TiN

Titanium Abutments - Titanio Gr. 5 - PVD TiN

SP 4ST 0° - Straight - Standard Gingival Profile

SP 4AT15 15° - Angled - Standard Gingival Profile

SP 4AT25 25° - Angled - Standard Gingival Profile

SP VIT40 Vite di Ricambio - Spare Screw

DMX 1/2 Standard Torx Driver



Pilastro Temporaneo - Titanio Gr. 5

Temporary Abutment - Titanium Gr. 5

SP 4TA Antirotation Hex - Standard Gingival Profile

SP 4TR Rotating - Standard Gingival Profile

SP VIT40 Vite di Ricambio - Spare Screw

DMX 1/2 Standard Torx Driver



4.1 regular prosthetics

32Ncm 



Link per Incollaggio TiB - Titanio Gr. 5

Bonding Technique Link TiB - Titanium Gr. 5

EP 4STB Link in Titanio Antirotazione - Compatibile TiB

EP VIT Vite di Ricambio - Spare Screw

DM 1/2 Standard Hexagonal Driver

25Ncm



Transfer e Analogo Digitale - Titanio Gr. 5

Scan Abutment and Digital Analog - Titanium Gr. 5

NSPSB41K Digital Scan Abutment

NSPAN3D41K Digital Analog + Fixing Screw

ACT VP Vite di Ricambio - Spare Screw

DMX 1/2 Standard Torque Driver

32Ncm 

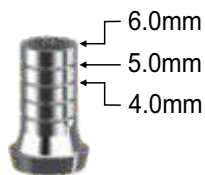

Adjustable in 3 heights

Link Base per Incollaggio Digitale - Titanio Gr. 5

Digital Bonding Technique Base Link - Titanium Gr. 5

NSPLK41K Gingival Profile **H 1mm** - Antirotazione Hex

NSPLKR41K Gingival Profile **H 1mm** - Rotating

ACT VP Vite di Ricambio - Spare Screw

DMX 1/2 Standard Torx Driver

32Ncm 



Kit Pilastro Equator per Overdenture - Titanio Gr. 5 - PVD

Overdenture Equator Abutment Kit - Titanium Gr. 5 - PVD

EP 4EQ2 H 2 mm - Narrow Gingival Profile

EP 4EQ3 H 3 mm - Narrow Gingival Profile

EP 4EQ4 H 4 mm - Narrow Gingival Profile

EP 4EQ5 H 5 mm - Narrow Gingival Profile

EP 4EQ6 H 6 mm - Narrow Gingival Profile

DM EQ Squared Equator Driver

4.1 regular toronto prosthetics

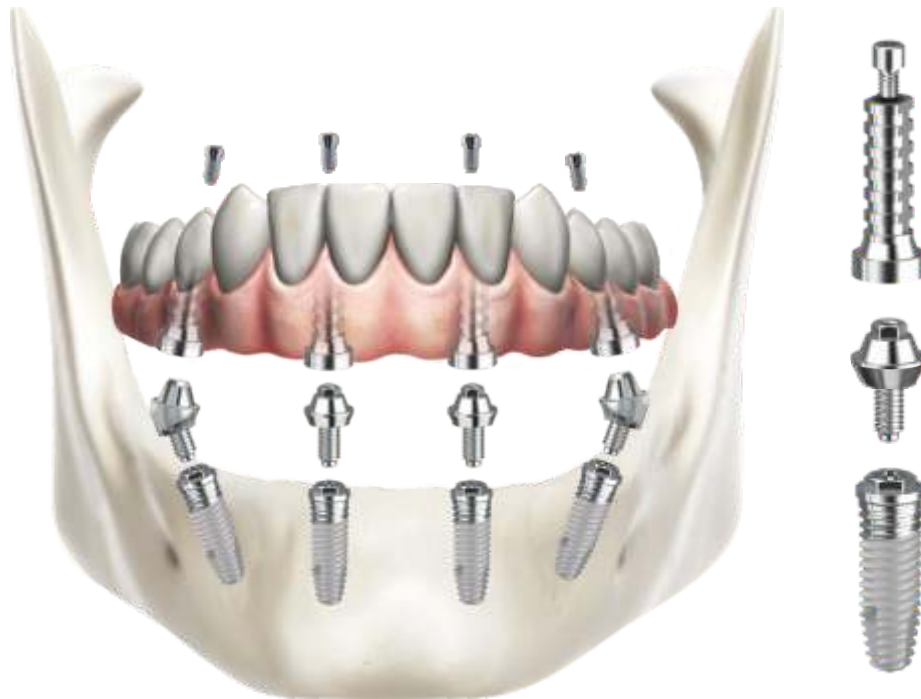

Pilastro Toronto 4 Diritto - Titanio Gr. 5

Toronto 4 Straight Abutment - Titanium Gr. 5

- EP MS2 H 2 mm - Standard Gingival Profile
- EP MS3 H 3 mm - Standard Gingival Profile



DCDM Toronto Straight Abutment Driver

Pilastro Toronto 4 Angolato - Titanio Gr. 5

Toronto 4 Angled Abutment - Titanium Gr. 5

- EP MA172 17° - H 2 mm - Standard Gingival Profile
- EP MA173 17° - H 3 mm - Standard Gingival Profile
- EP MA303 30° - H 3 mm - Standard Gingival Profile
- EP MA304 30° - H 4 mm - Standard Gingival Profile



EP VITMA Vite di Ricambio Toronto - Toronto Spare Screw

DMX 1/2 Standard Torx Driver

Pilastro Temporaneo Toronto - Titanio Gr. 5

Toronto Temporary Abutment - Titanium Gr. 5

- EP MT Rotating - Bonding Technique - Incollaggio Passivo
- EP MTS Rotating - Welding Technique - Saldatura Intraorale
- EP MV Vite di Ricambio Toronto - Toronto Spare Screw





DMX 1/2 Standard Torx Driver

4.1 regular toronto prosthetics

15Ncm 



10Ncm 



Componenti Protesiche Toronto

Toronto Prosthetics

EP MC Castable Rotating Abutment - Acrylic

EP MI Toronto Impression Coping - Rotating

EP MV Vite Ricambio - Toronto Spare Screw

EP MVL Vite Ricambio Lunga - Long Toronto Spare Screw

DMX 1/2 Standard Torx Driver

15Ncm 



Pilastro di Guarigione Toronto

Toronto Healing Abutment

EP MHA H 4 mm - Standard Gingival Profile Titanium Gr5

EP MHA6 H 6 mm - Large Gingival Profile Titanium Gr5

DMX 1/2 Standard Torx Driver

Toronto Digital Solutions

Transfer Toronto per Impronta Digitale - Titanio Gr. 5

Toronto Scan Abutment - Titanium Gr. 5

EP MSA2 DS Rotating Scan Abutment - Transfer Digitale Rotante

EP MV Vite di Ricambio Toronto - Toronto Spare Screw

DMX 1/2 Standard Torx Driver

15Ncm 



Link Base per Incollaggio - Titanio Gr. 5

Bonding Technique Base Link - Titanium Gr. 5

EP MT DS Rotating - Bonding Technique - Incollaggio Passivo

EP MV Vite di Ricambio Toronto - Toronto Spare Screw

DMX 1/2 Standard Torx Driver

15Ncm 



Adjustable in 5 heights

Analogo Toronto per Laboratorio - Titanio Gr. 5

Laboratory Toronto Analog - Titanium Gr. 5

EP MAL2DS Digital Universal Toronto Analog

DM 1/2 Standard Hexagonal Driver Ø 1.27



ES 50



CYLINDRICAL SHAPE
Wide External Hexagon

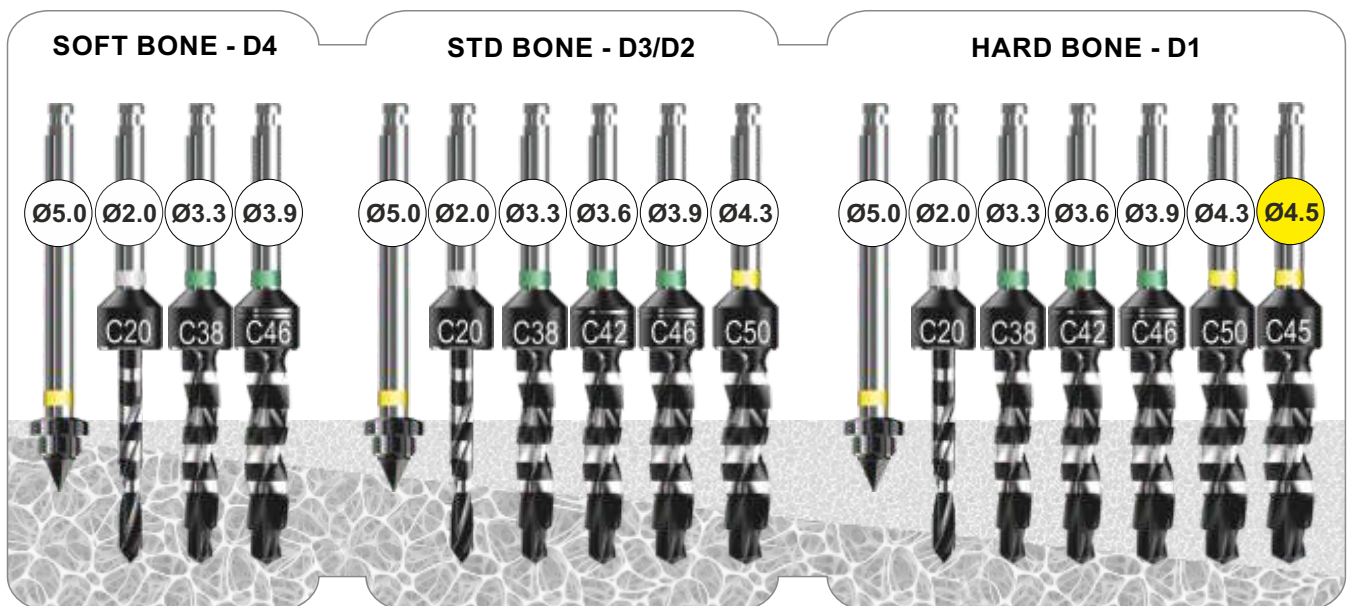
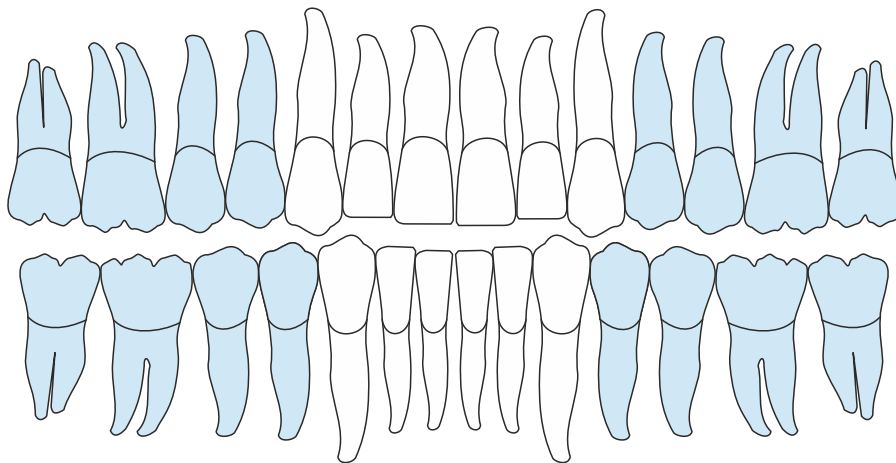
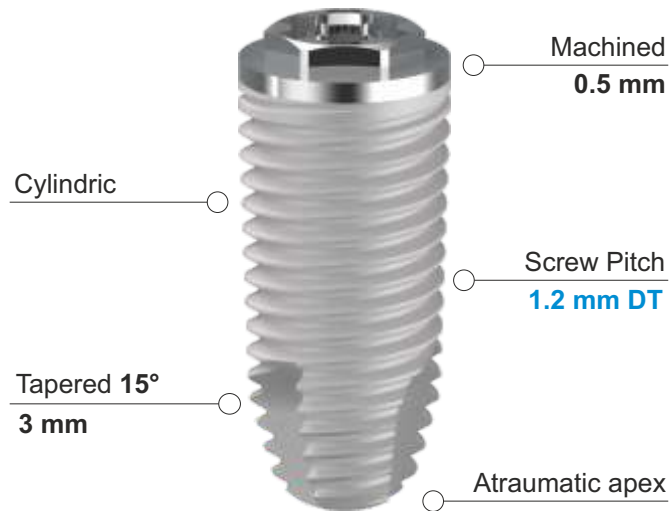

Velocità di rotazione frese consigliata 500 - 800 rpm

Recommended milling burs rotation speed 500 - 800 rpm

5.0 Full Treatment - Mounterless



CODE	IMPLANT	LENGTH	PLATFORM	APEX
ES 5008	Ø 5.0	8,5 mm	Ø 5.0	Ø 3.5
ES 5010	Ø 5.0	10 mm	Ø 5.0	Ø 3.5
ES 5011	Ø 5.0	11.5 mm	Ø 5.0	Ø 3.5
ES 5013	Ø 5.0	13 mm	Ø 5.0	Ø 3.5

5.0 Half Treatment - Mounterless



CODE	IMPLANT	LENGTH	PLATFORM	APEX
ES 5008 HT	Ø 5.0	8,5 mm	Ø 5.0	Ø 3.5
ES 5010 HT	Ø 5.0	10 mm	Ø 5.0	Ø 3.5
ES 5011 HT	Ø 5.0	11.5 mm	Ø 5.0	Ø 3.5
ES 5013 HT	Ø 5.0	13 mm	Ø 5.0	Ø 3.5



5.0 wide prosthetics

Pilastro di Guarigione - Titanio Gr. 5 - Anodizzato

Healing Abutment - Titanium Gr. 5 - Anodized

SP 5HA3 H 3 mm - Large Gingival Profile

SP 5HA5 H 5 mm - Large Gingival Profile

DMX 1/2 Standard Torx Driver



Analogo per Laboratorio - Titanio Gr. 5 - Anodizzato

Laboratory Analog - Titanium Gr. 5 - Anodized

SP 5AL H 12 mm - Large Shape



Moncone Calcinabile - Acrilico

Castable Abutment - Acrylic

SP 5CA Antirotation Hex - Narrow Gingival Profile

SP 5CR Rotating - Large Gingival Profile

SP VIT50 Vite di Ricambio - Spare Screw

DMX 1/2 Standard Torx Driver



Moncone Titanio - Titanio Gr. 5 - PVD TiN

Titanium Abutment - Titanium Gr. 5 - PVD TiN

SP 5ST 0° - Straight - Large Gingival Profile

SP VIT50 Vite di Ricambio - Spare Screw

DMX 1/2 Standard Torx Driver



Pilastro Temporaneo con Esagono - Titanio Gr. 5

Antirotation Hex Temporary Abutment - Titanium Gr. 5

SP 5TA Antirotation Hex - Narrow Gingival Profile

SP VIT50 Vite di Ricambio - Spare Screw

DMX 1/2 Standard Torx Driver



5.0 wide prosthetics

32Ncm 



Pilastro Temporaneo senza Esagono - Titanio Gr. 5

Rotating Temporary Abutment - Titanium Gr. 5

SP 5TR Rotating - Narrow Gingival Profile

SP VIT50 Vite di Ricambio - Spare Screw

DMX 1/2 Toronto Abutment Torx Driver

32Ncm 



Transfer per Impronta Pick Up - Titanio Gr. 5

Pick Up Impression Coping - Titanium Gr. 5

SP 5IA H 12mm - Narrow Gingival Profile

SP VITL50 Vite di Ricambio - Spare Screw

DMX 1/2 Toronto Abutment Torx Driver







12° CONICAL CONNECTION

NARROW PLATINUM

TAPERED
SHAPE



IK-P

IK 34-P



TAPERED SHAPE Conical Connection Internal Hexagon

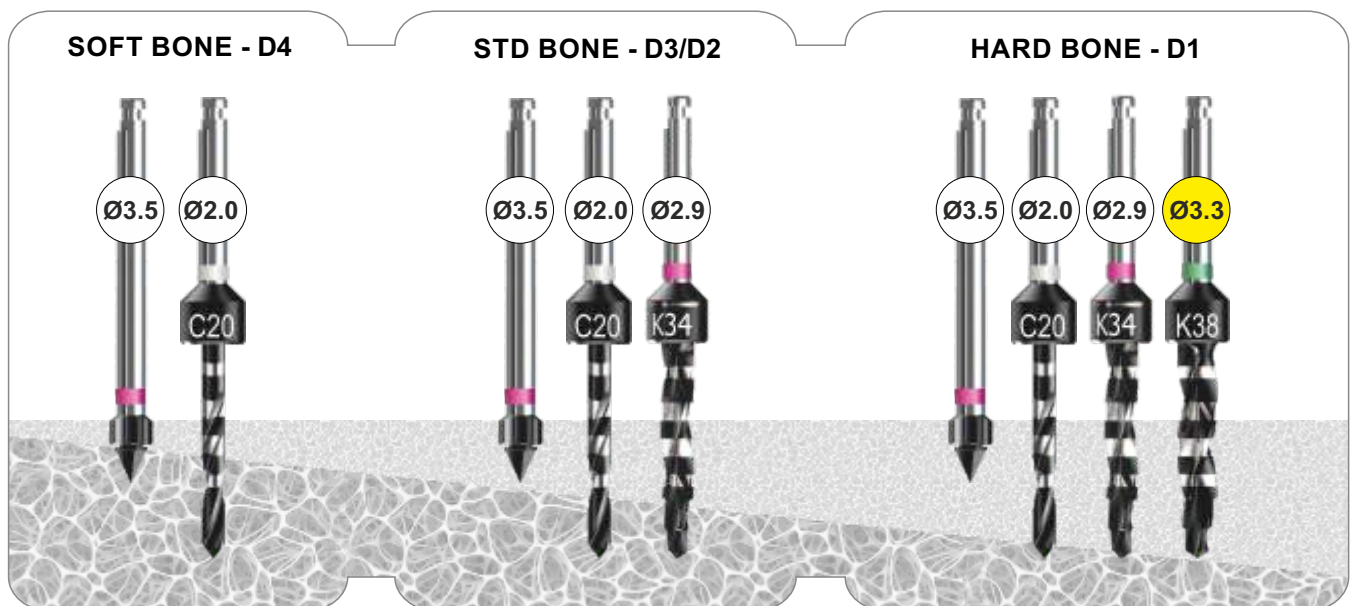
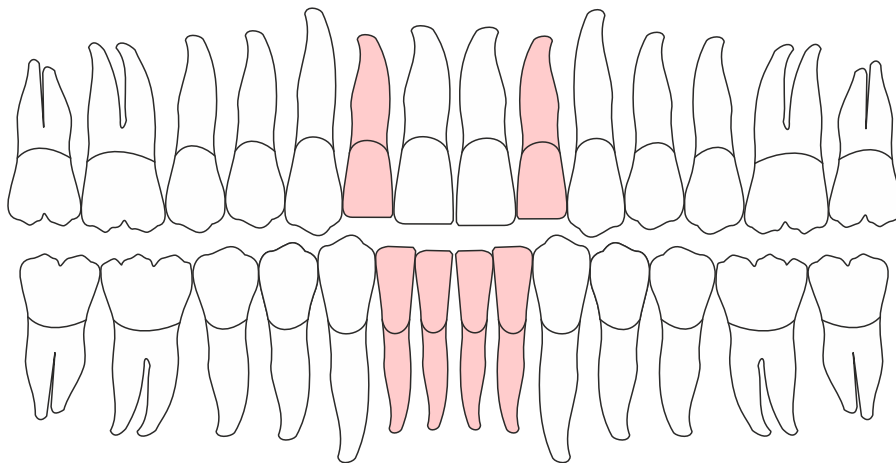
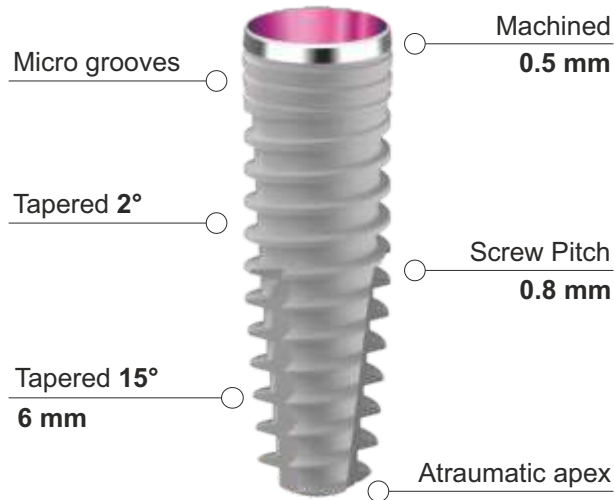

Velocità di rotazione frese consigliata 500 - 800 rpm

Recommended milling burs rotation speed 500 - 800 rpm

IK 38-P



TAPERED SHAPE Conical Connection Internal Hexagon

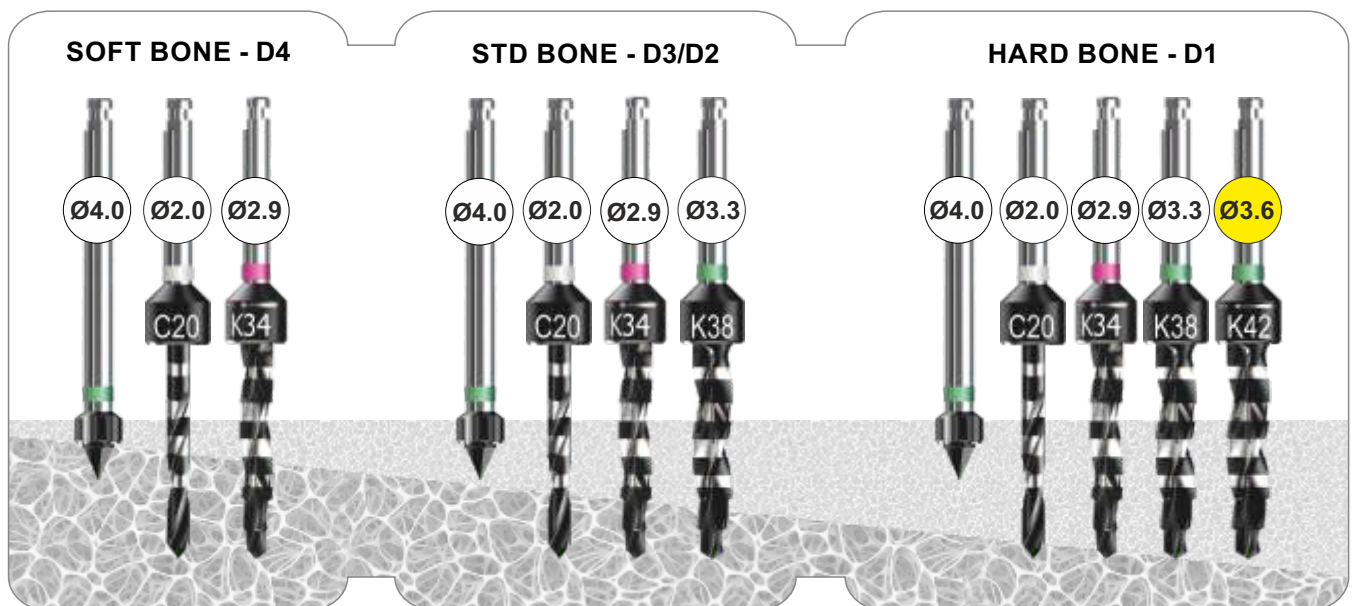
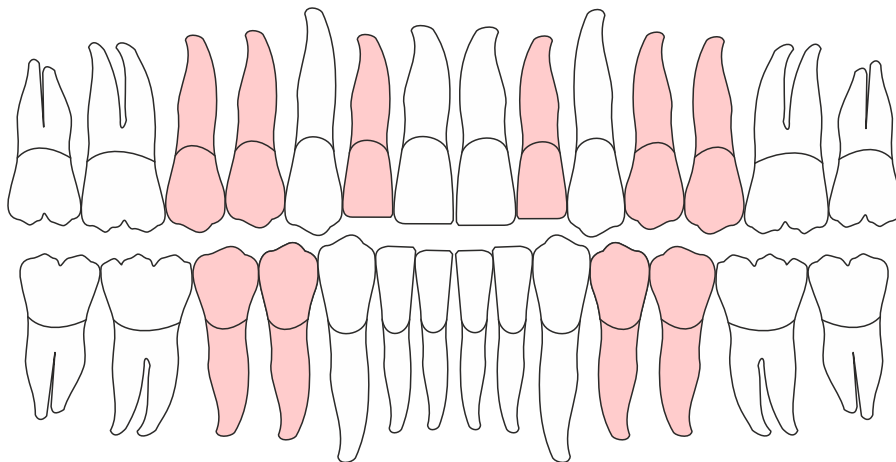
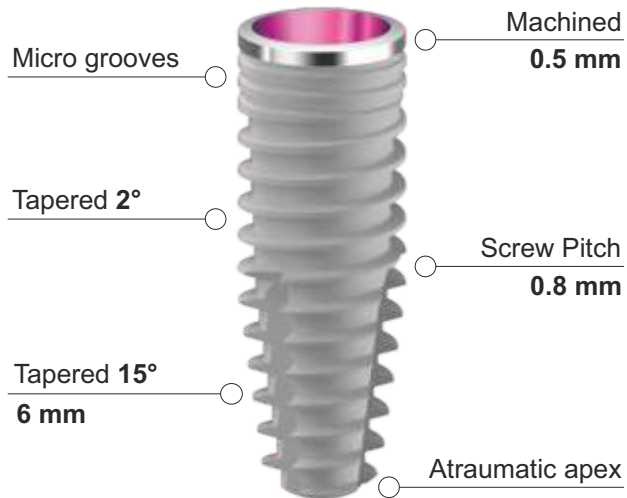

Velocità di rotazione frese consigliata 500 - 800 rpm

Recommended milling burs rotation speed 500 - 800 rpm

3.4 Full Treatment - Mounterless



CODE	IMPLANT	LENGTH	NECK	APEX
IK 3407 P	Ø 3.4	7.0 mm	Ø 3.5	Ø 1.8
IK 3408 P	Ø 3.4	8.5 mm	Ø 3.5	Ø 1.8
IK 3410 P	Ø 3.4	10 mm	Ø 3.5	Ø 1.8
IK 3411 P	Ø 3.4	11.5 mm	Ø 3.5	Ø 1.8
IK 3413 P	Ø 3.4	13 mm	Ø 3.5	Ø 1.8
IK 3415 P	Ø 3.4	15 mm	Ø 3.5	Ø 1.8

3.8 Full Treatment - Mounterless



CODE	IMPLANT	LENGTH	NECK	APEX
IK 3808 P	Ø 3.8	8.5 mm	Ø 3.8	Ø 1.9
IK 3810 P	Ø 3.8	10 mm	Ø 3.8	Ø 1.9
IK 3811 P	Ø 3.8	11.5 mm	Ø 3.8	Ø 1.9
IK 3813 P	Ø 3.8	13 mm	Ø 3.8	Ø 1.9
IK 3815 P	Ø 3.8	15 mm	Ø 3.8	Ø 1.9



12° CONICAL CONNECTION

NARROW PLATINUM

ACTIVE BLADE SHAPE



IA-P

IA 34-P



ACTIVE BLADE SHAPE Conical Connection Internal Hexagon

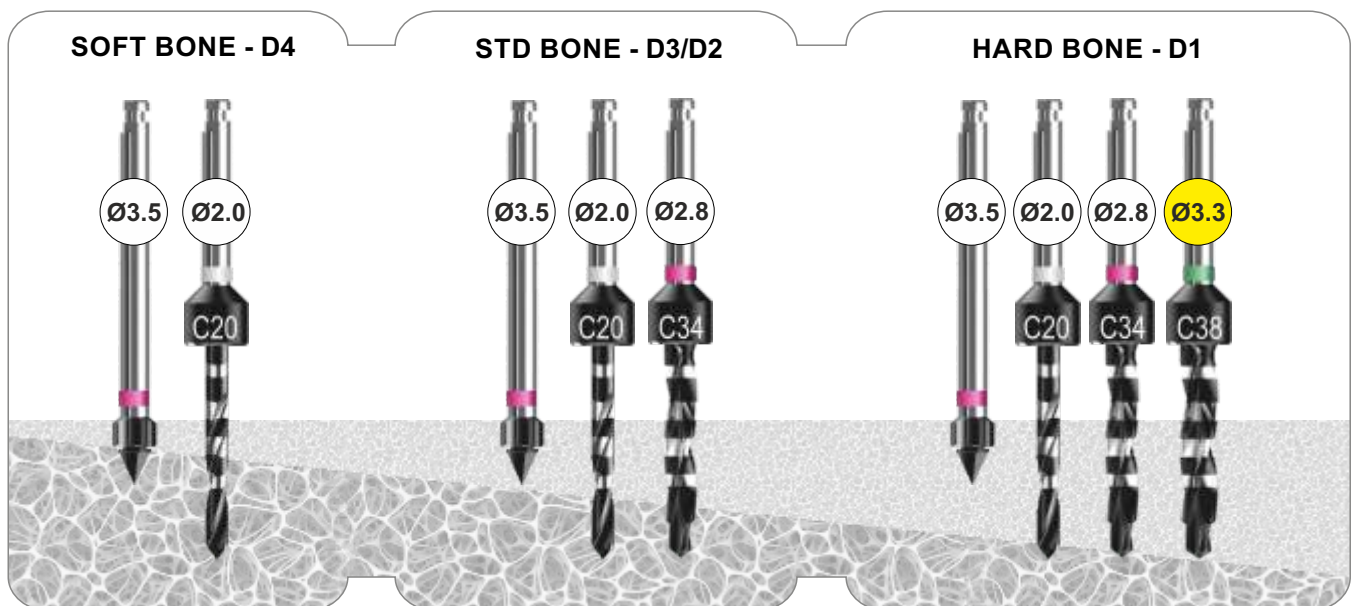
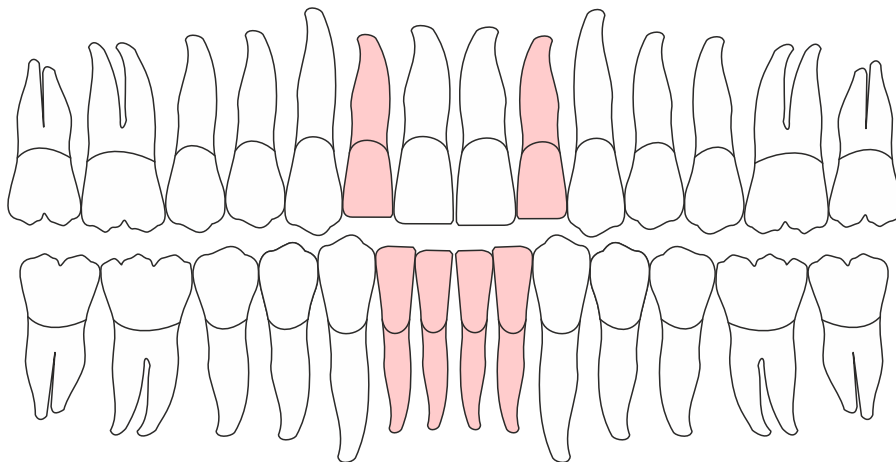
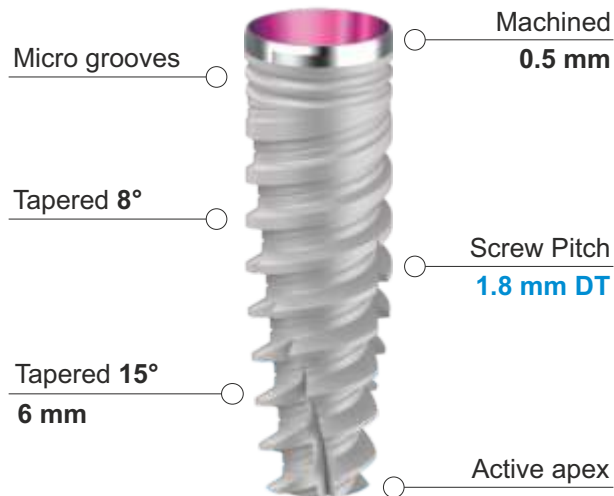

Velocità di rotazione frese consigliata 500 - 800 rpm

Recommended milling burs rotation speed 500 - 800 rpm

IA 38-P



ACTIVE BLADE SHAPE Conical Connection Internal Hexagon

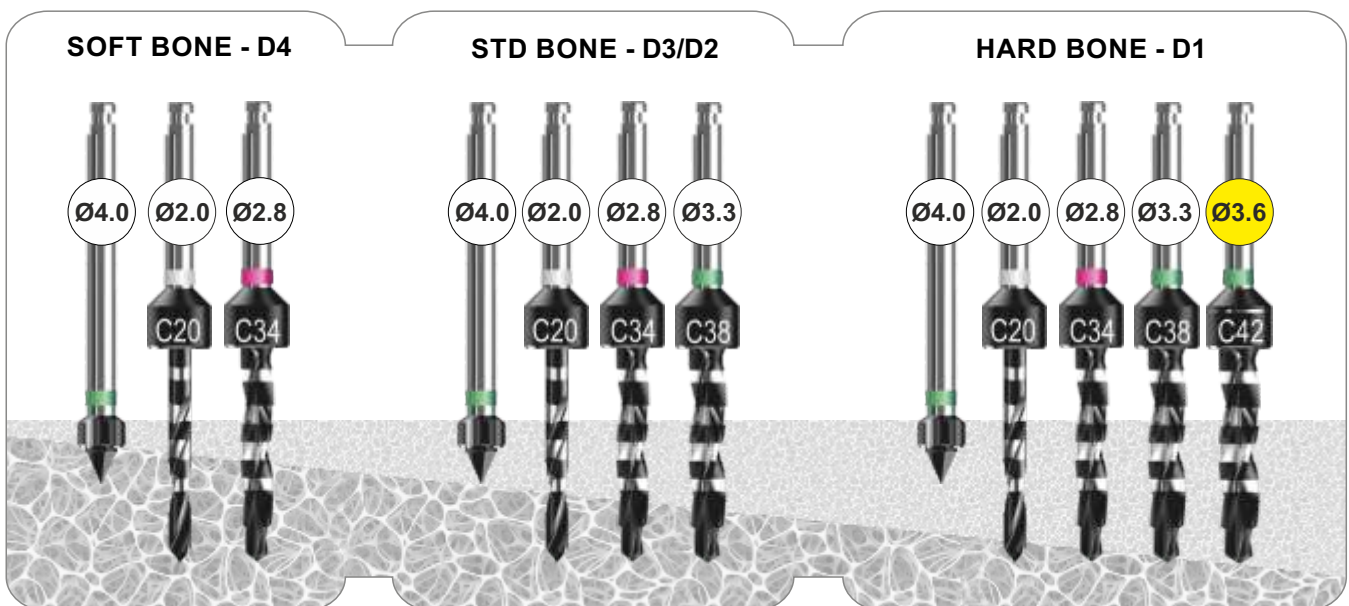
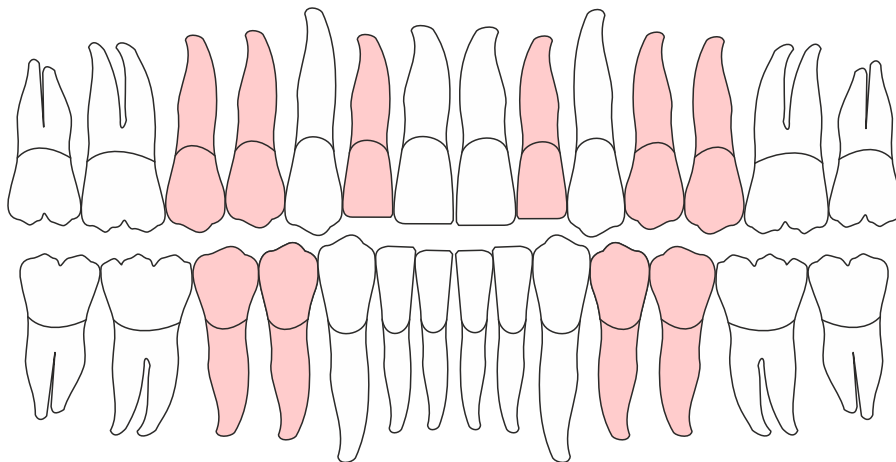
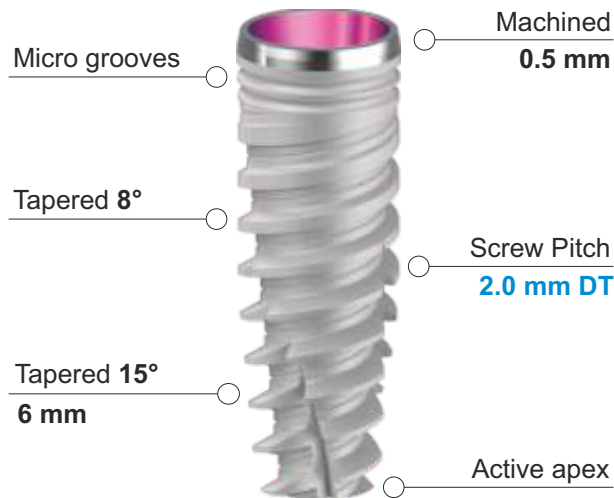

Velocità di rotazione frese consigliata 500 - 800 rpm

Recommended milling burs rotation speed 500 - 800 rpm

3.4 Full Treatment - Mounterless



CODE	IMPLANT	LENGTH	NECK	APEX
IA 3408 P	Ø 3.4	8.5 mm	Ø 3.5	Ø 2.2
IA 3410 P	Ø 3.4	10 mm	Ø 3.5	Ø 2.2
IA 3411 P	Ø 3.4	11.5 mm	Ø 3.5	Ø 2.2
IA 3413 P	Ø 3.4	13 mm	Ø 3.5	Ø 2.2
IA 3415 P	Ø 3.4	15 mm	Ø 3.5	Ø 2.2

3.8 Full Treatment - Mounterless



CODE	IMPLANT	LENGTH	NECK	APEX
IA 3808 P	Ø 3.8	8.5 mm	Ø 3.8	Ø 2.5
IA 3810 P	Ø 3.8	10 mm	Ø 3.8	Ø 2.5
IA 3811 P	Ø 3.8	11.5 mm	Ø 3.8	Ø 2.5
IA 3813 P	Ø 3.8	13 mm	Ø 3.8	Ø 2.5
IA 3815 P	Ø 3.8	15 mm	Ø 3.8	Ø 2.5



12° CONICAL CONNECTION

NARROW PLATINUM

SPEEDY
SHAPE



ES-P

ES 34-P



SPEEDY SHAPE Conical Connection Internal Hexagon

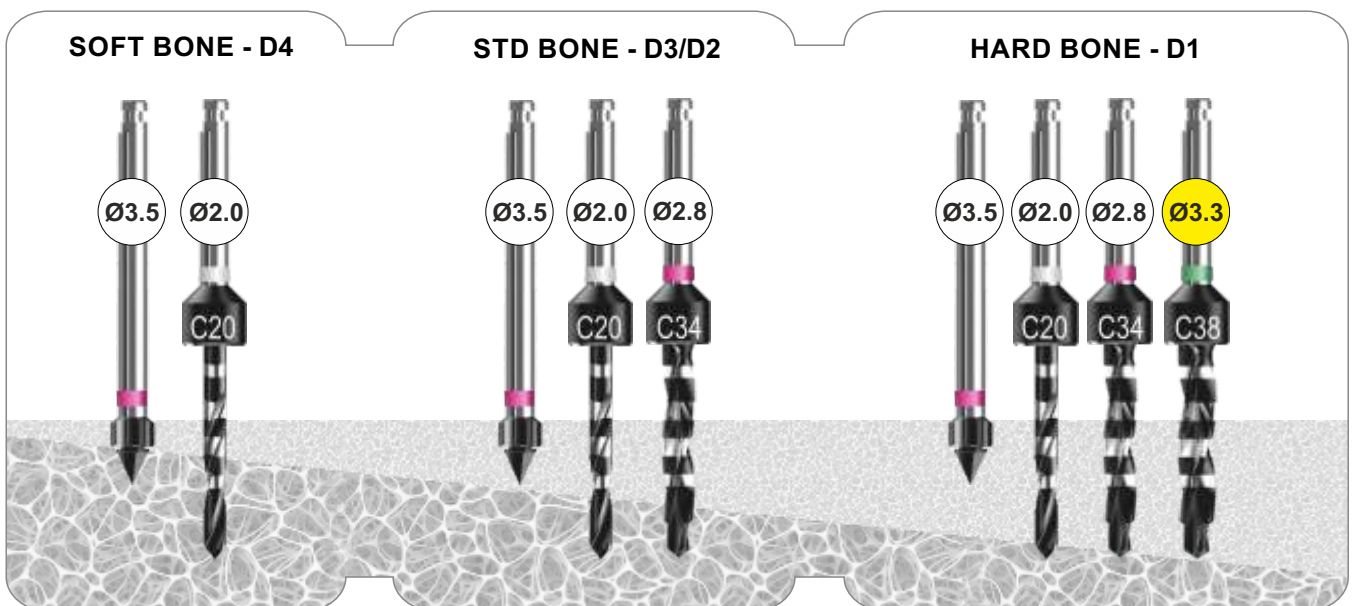
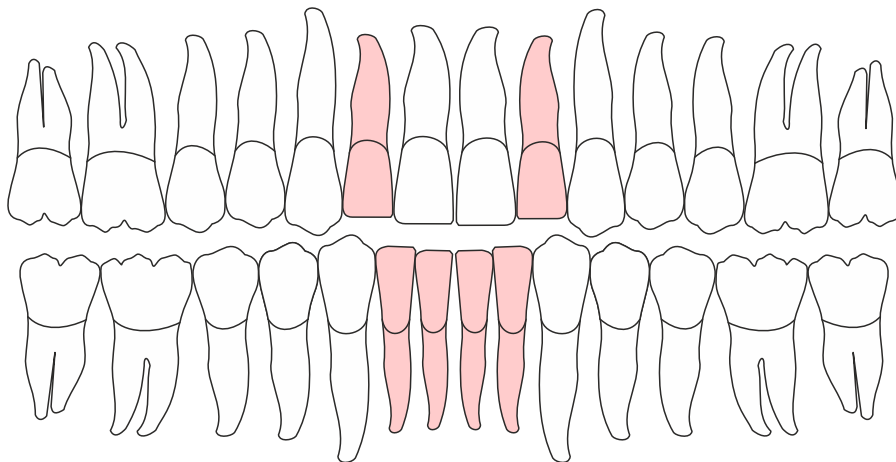
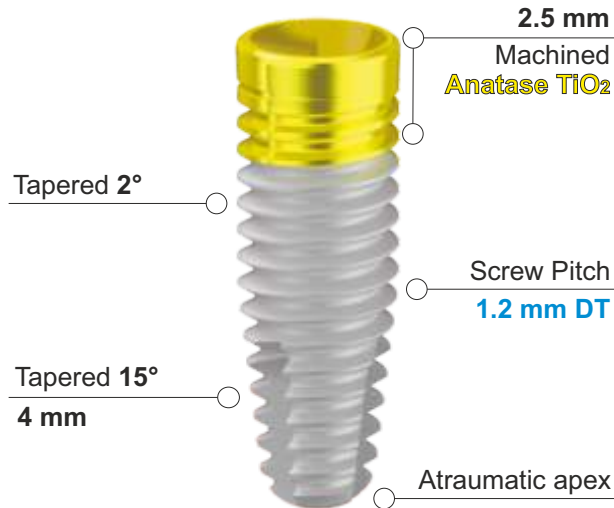

Velocità di rotazione frese consigliata 500 - 800 rpm

Recommended milling burs rotation speed 500 - 800 rpm

ES 38-P



SPEEDY SHAPE Conical Connection Internal Hexagon

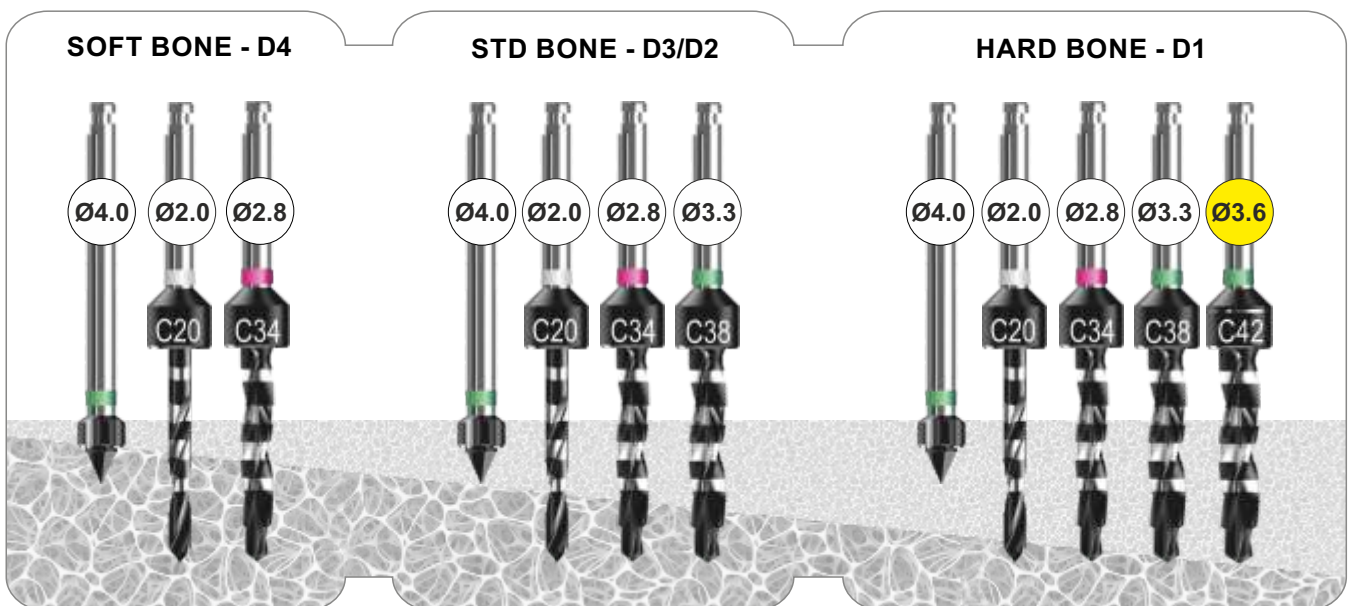
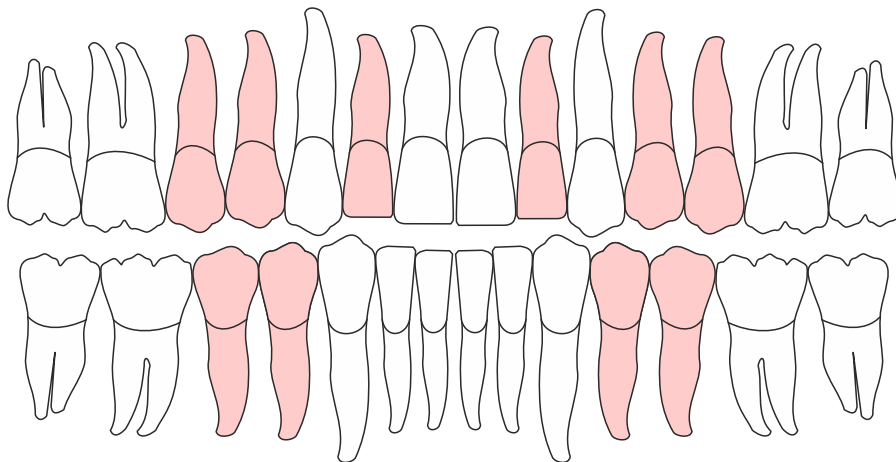
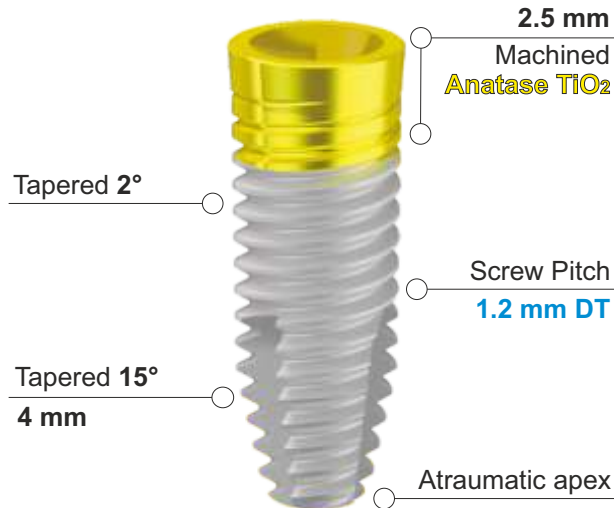

Velocità di rotazione frese consigliata 500 - 800 rpm

Recommended milling burs rotation speed 500 - 800 rpm

3.4 Full Treatment - Mounterless



CODE	IMPLANT	LENGTH	NECK	APEX
ES 3408 P	Ø 3.4	8.5 mm	Ø 3.5	Ø 2.0
ES 3410 P	Ø 3.4	10 mm	Ø 3.5	Ø 2.0
ES 3411 P	Ø 3.4	11.5 mm	Ø 3.5	Ø 2.0
ES 3413 P	Ø 3.4	13 mm	Ø 3.5	Ø 2.0
ES 3415 P	Ø 3.4	15 mm	Ø 3.5	Ø 2.0

3.8 Full Treatment - Mounterless



CODE	IMPLANT	LENGTH	NECK	APEX
ES 3808 P	Ø 3.8	8.5 mm	Ø 3.8	Ø 2.2
ES 3810 P	Ø 3.8	10 mm	Ø 3.8	Ø 2.2
ES 3811 P	Ø 3.8	11.5 mm	Ø 3.8	Ø 2.2
ES 3813 P	Ø 3.8	13 mm	Ø 3.8	Ø 2.2
ES 3815 P	Ø 3.8	15 mm	Ø 3.8	Ø 2.2



12° CONICAL CONNECTION

NARROW PLATINUM

NARROW PROSTHETICS



narrow CCP prosthetics

20Ncm 



Pilastro di Guarigione - Titanio Gr. 5 - Anodizzato

Healing Abutment - Titanium Gr. 5 - Anodized

IP 3HA3-P H 3 mm - Narrow Gingival Profile

IP 3HA4-P H 4 mm - Narrow Gingival Profile

IP 3HA5-P H 5 mm - Narrow Gingival Profile

DMX 1/2 Standard Torx Driver



Analogo per Laboratorio - Titanio Gr. 5 - Anodizzato

Laboratory Analog - Titanium Gr. 5 - Anodized

IP 3AL-P H 12 mm - Universal Shape

25Ncm 



Moncone UCLA Cobalto Cromo - CoCr

UCLA Abutment Cobalt Chrome - CoCr

IP 3CCA-P Antirotation Hex - Narrow Gingival Profile H1,5mm

IP 3CCR-P Rotating - Narrow Gingival Profile H1,5mm

IP VIT3-P Vite di Ricambio - Spare Screw

DMX 1/2 Standard Torx Driver

25Ncm 



Moncone Titanio Dritto - Titanio Gr. 5

Straight Titanium Abutment - Titanium Gr. 5

IP 3ST1-P 0° - Straight - Narrow Gingival Profile H1.5mm

IP 3ST3-P 0° - Straight - Narrow Gingival Profile H3.0mm

IP 3ST4-P 0° - Straight - Narrow Gingival Profile H4.0mm

IP VIT3-P Vite di Ricambio - Spare Screw

DMX 1/2 Standard Torx Driver

25Ncm 



Moncone Titanio Preangolato 15° - Titanio Gr. 5

15° Angled Titanium Abutment - Titanium Gr. 5

IP 3AT151-P 15° - Angled - Narrow Gingival Profile H1.5mm

IP 3AT153-P 15° - Angled - Narrow Gingival Profile H3.0mm

IP 3AT154-P 15° - Angled - Narrow Gingival Profile H4.0mm

IP VIT3-P Vite di Ricambio - Spare Screw

DMX 1/2 Standard Torx Driver

narrow CCP prosthetics

Moncone Titanio Preangolato 25° - Titanio Gr. 5

25° Angled Titanium Abutment - Titanium Gr. 5

IP 3AT251-P 25° - Angled - Narrow Gingival Profile H1.5mm

IP 3AT253-P 25° - Angled - Narrow Gingival Profile H3.0mm

IP 3AT254-P 25° - Angled - Narrow Gingival Profile H4.0mm

IP VIT3-P Vite di Ricambio - Spare Screw

DMX 1/2 Standard Torx Driver



Pilastro Temporaneo da Incollaggio - Ti Gr. 5

Temporary Glueing Abutment - Ti Gr. 5

IP 3TA1-P Antirotaion Hex - Narrow Gingival Profile H 1.5mm

IP 3TA3-P Antirotaion Hex - Narrow Gingival Profile H 3.0mm

IP 3TR1-P Rotating - Narrow Gingival Profile H 1.5mm

IP 3TR3-P Rotating - Narrow Gingival Profile H 3.0mm

DMX 1/2 Standard Torx Driver



Pilastro per Overdenture - Titanio Gr. 5 - PVD TiN

Overdenture Abutment - Titanium Gr. 5 - PVD TiN

IP 3BA1-P H 1 mm - Narrow Gingival Profile - NORMO

IP 3BA2-P H 2 mm - Narrow Gingival Profile - NORMO

IP 3BA3-P H 3 mm - Narrow Gingival Profile - NORMO

IP 3BA4-P H 4 mm - Narrow Gingival Profile - NORMO

DMX 1/2 Standard Torx Driver



Kit Pilastro Equator per Overdenture - Titanio Gr. 5 - PVD

Overdenture Equator Abutment Kit - Titanium Gr. 5 - PVD

IP 3EQ1-P H 1 mm - Narrow Gingival Profile

IP 3EQ2-P H 2 mm - Narrow Gingival Profile

IP 3EQ3-P H 3 mm - Narrow Gingival Profile

IP 3EQ5-P H 5 mm - Narrow Gingival Profile

DM EQ Squared Equator Driver



Transfer per impronta Pick Up - Titanio Gr. 5

Pick Up Impression Coping - Titanium Gr. 5

IP 3IA1-P Narrow Gingival Profile - H1.5mm

IP 3IA3-P Narrow Gingival Profile - H3.0mm

IP 3IA4-P Narrow Gingival Profile - H4.0mm

IP VIT3L-P Vite di Ricambio - Spare Screw

DMX 1/2 Standard Torx Driver



toronto narrow CCP prosthetics



25Ncm



Pilastro Toronto Diritto - Titanio Gr. 5

Toronto Straight Abutment - Titanium Gr. 5

- IP 3MS1-P H 1.5 mm - Standard Gingival Profile
- IP 3MS3-P H 3.0 mm - Standard Gingival Profile
- IP 3MS4-P H 4.0 mm - Standard Gingival Profile

DCDM

Toronto Straight Abutment Driver

25Ncm



Pilastro Toronto Angolato 17° - Titanio Gr. 5

Toronto 17° Angled Abutment - Titanium Gr. 5

- IP 3MA172-P 17° - H 2 mm - Standard Gingival Profile
- IP 3MA173-P 17° - H 3 mm - Standard Gingival Profile

IP 3VITMA-P Vite di Ricambio Toronto - Toronto Spare Screw
DMX 1/2 Standard Torx Driver

25Ncm



Pilastro Toronto Angolato 30° - Titanio Gr. 5

Toronto 30° Angled Abutment - Titanium Gr. 5

- IP 3MA303-P 30° - H 3 mm - Standard Gingival Profile
- IP 3MA304-P 30° - H 4 mm - Standard Gingival Profile

IP 3VITMA-P Vite di Ricambio Toronto - Toronto Spare Screw
DMX 1/2 Standard Torx Driver

toronto narrow CCP prosthetics

Pilastro Calcinabile Toronto & Pilastro di Guarigione

Toronto Castable Abutment & Healing Abutment

- EP MC** Rotating Castable Abutment
- EP MHA** H 4 mm - Standard Gingival Profile Titanium Gr5
- EP MHA6** H 6 mm - Large Gingival Profile Titanium Gr5
- EP MV** Vite di Ricambio Toronto - Toronto Spare Screw
- DMX 1/2** Standard Torx Driver

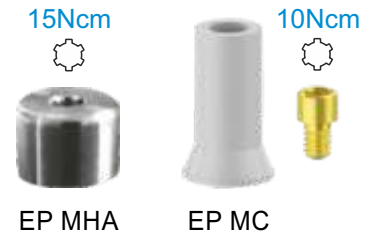

Componenti Protesiche Toronto - Titanio Gr. 5

Toronto Prosthetics - Titanium Gr. 5

- EP MI** Rotating - Standard Gingival Profile
- EP MAL2DS** Digital Toronto Analog - Analogo Digitale
- EP MT** Rotating Temporary - Incollaggio Passivo
- EP MTS** Rotating Welding Temporary - Saldatura Intraorale
- EP MVL** Vite di Ricambio Lunga - Long Spare Screw
- DMX 1/2** Standard Torx Driver



Transfer Toronto & Link da Incollaggio - Titanio Gr. 5

Toronto Scan Abutment & Link - Titanium Gr. 5

- EP MSA2 DS** Toronto Rotating Scan Abutment
- EP MT DS** Toronto Rotating - Bonding Technique Link
- EP MV** Vite di Ricambio Toronto - Toronto Spare Screw
- DMX 1/2** Standard Torx Driver

Digital Solutions



Componenti Digitali CCP - Titanio Gr. 5

CCP Digital Components - Titanium Gr. 5

- ACT SB35K** Antirotational Scan Abutment
- ACT LKN35K** Antirotational Bonding Technique Link
- ACT LKR35K** Rotating Bonding Technique Link
- ACT AN3D35K** CAD Laboratory Analog
- ACT VP16** Vite di Ricambio - Spare Screw
- DMX 1/2** Standard Torx Driver





12° CONICAL CONNECTION

REGULAR PLATINUM

TAPERED
SHAPE



IK-P

IK 42-P

TAPERED SHAPE Conical Connection Internal Hexagon

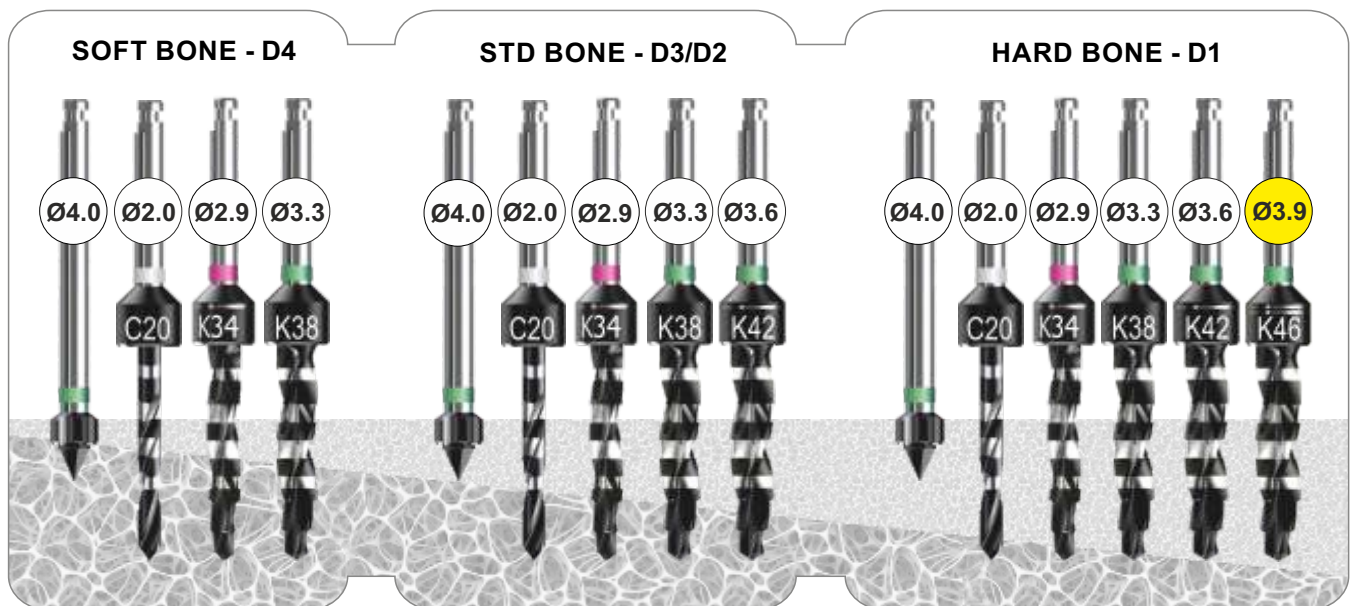
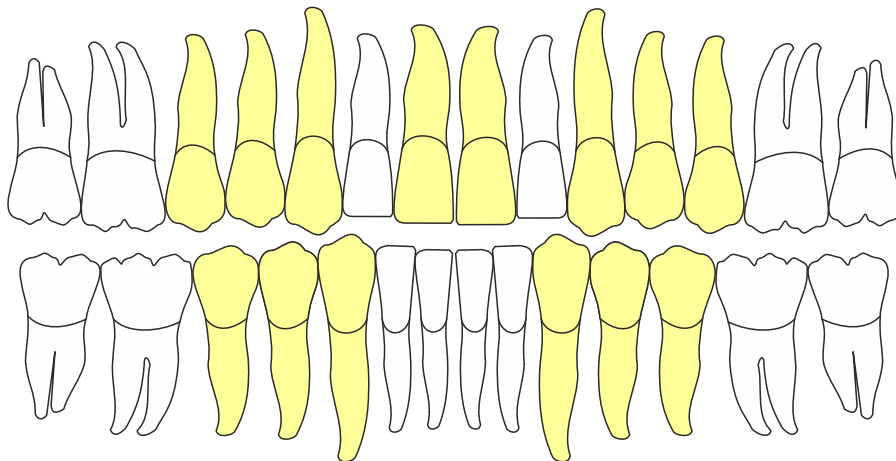
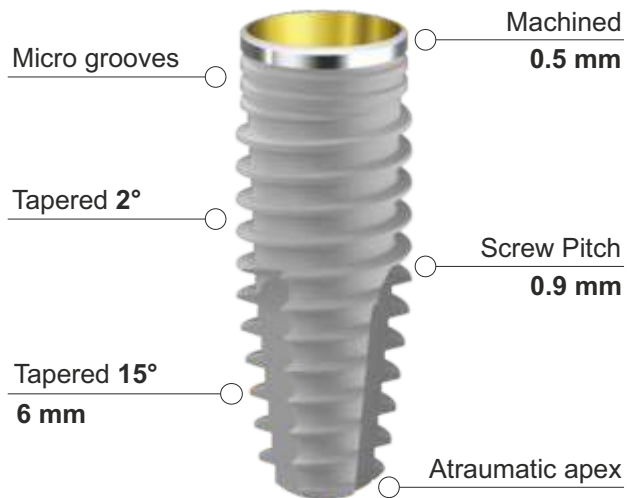

Velocità di rotazione frese consigliata 500 - 800 rpm

Recommended milling burs rotation speed 500 - 800 rpm

IK 50-P

TAPERED SHAPE Conical Connection Internal Hexagon

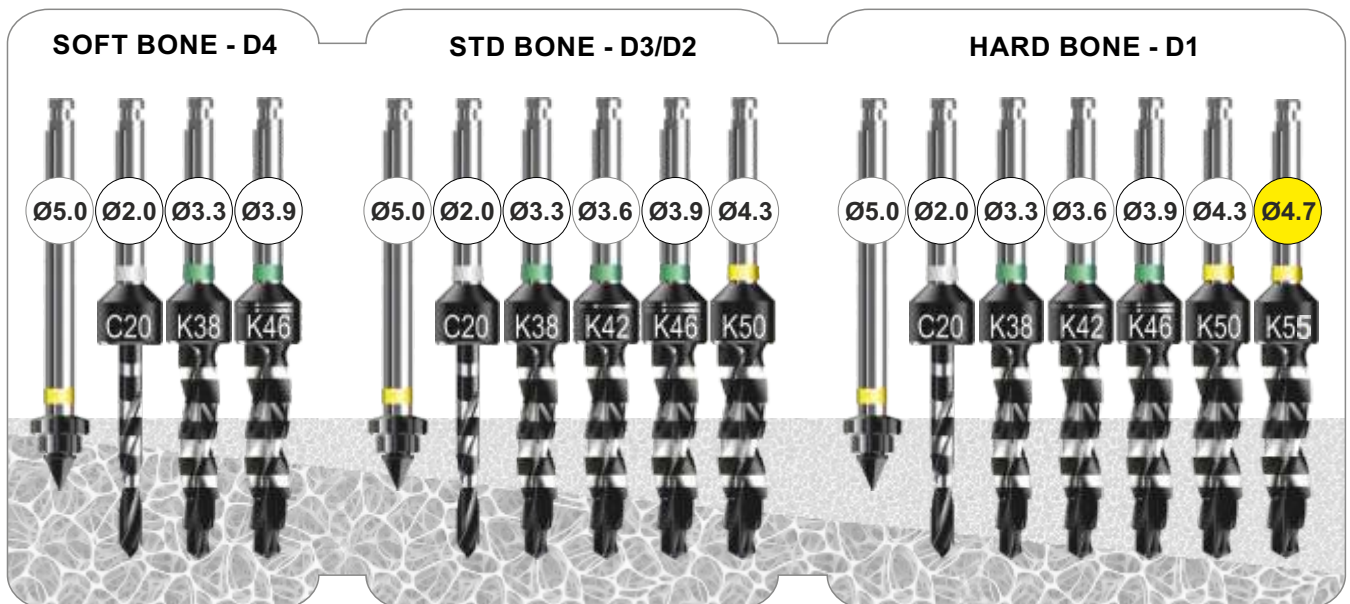
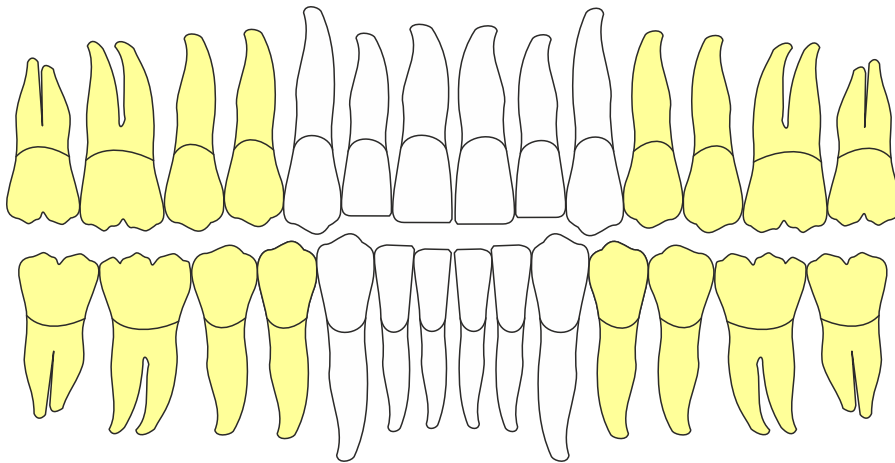
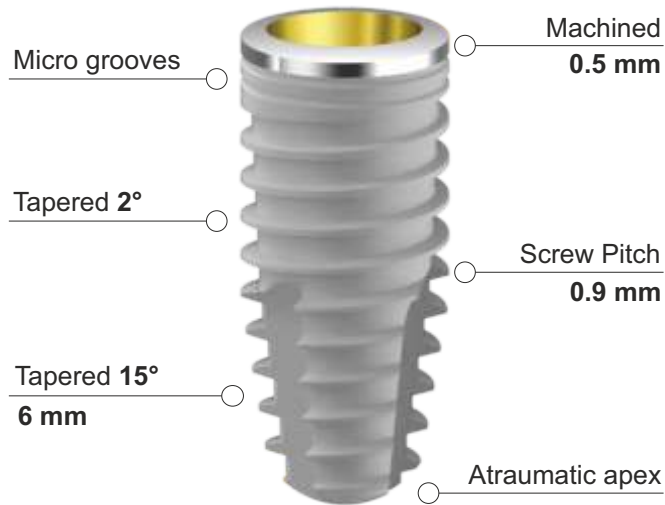

Velocità di rotazione frese consigliata 500 - 800 rpm

Recommended milling burs rotation speed 500 - 800 rpm

4.2 Full Treatment - Mounterless



CODE	IMPLANT	LENGTH	NECK	APEX
IK 4207 P	Ø 4.2	7.0 mm	Ø 4.0	Ø 2.3
IK 4208 P	Ø 4.2	8.5 mm	Ø 4.0	Ø 2.3
IK 4210 P	Ø 4.2	10 mm	Ø 4.0	Ø 2.3
IK 4211 P	Ø 4.2	11.5 mm	Ø 4.0	Ø 2.3
IK 4213 P	Ø 4.2	13 mm	Ø 4.0	Ø 2.3
IK 4215 P	Ø 4.2	15 mm	Ø 4.0	Ø 2.3

5.0 Full Treatment - Mounterless



CODE	IMPLANT	LENGTH	NECK	APEX
IK 5007 P	Ø 5.0	7.0 mm	Ø 4.8	Ø 2.7
IK 5008 P	Ø 5.0	8.5 mm	Ø 4.8	Ø 2.7
IK 5010 P	Ø 5.0	10 mm	Ø 4.8	Ø 2.7
IK 5011 P	Ø 5.0	11.5 mm	Ø 4.8	Ø 2.7
IK 5013 P	Ø 5.0	13 mm	Ø 4.8	Ø 2.7



12° CONICAL CONNECTION

REGULAR PLATINUM

ACTIVE BLADE
SHAPE



IA-P

IA 42-P

TAPERED SHAPE Conical Connection Internal Hexagon

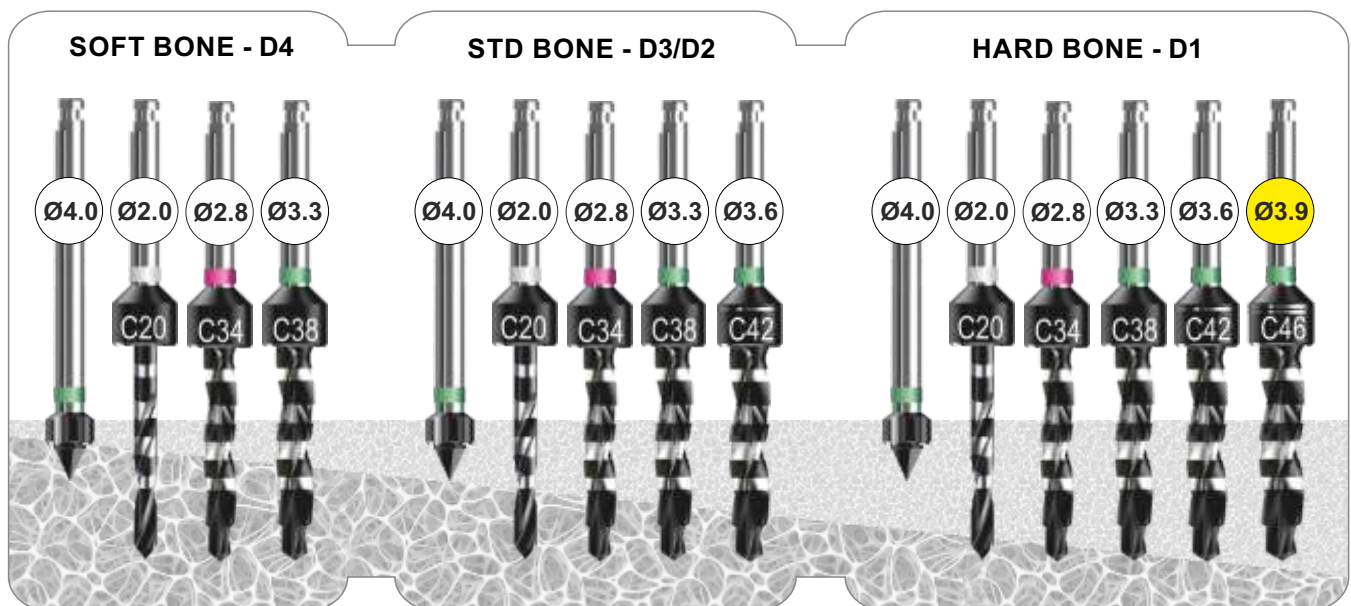
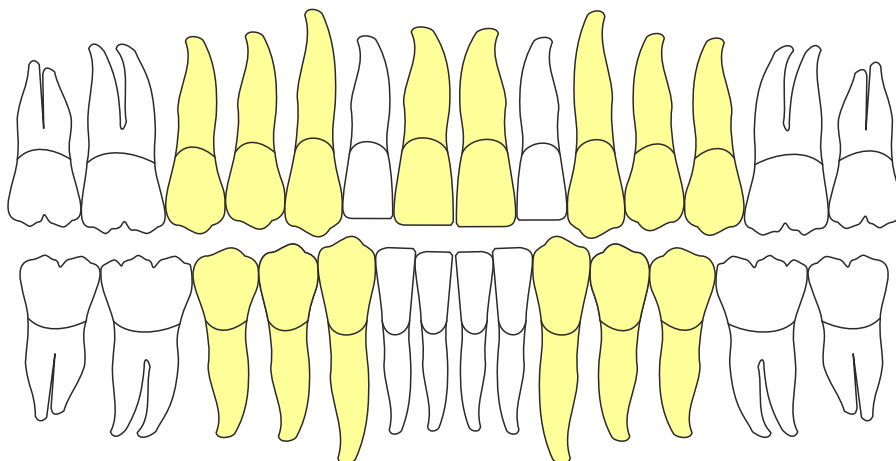
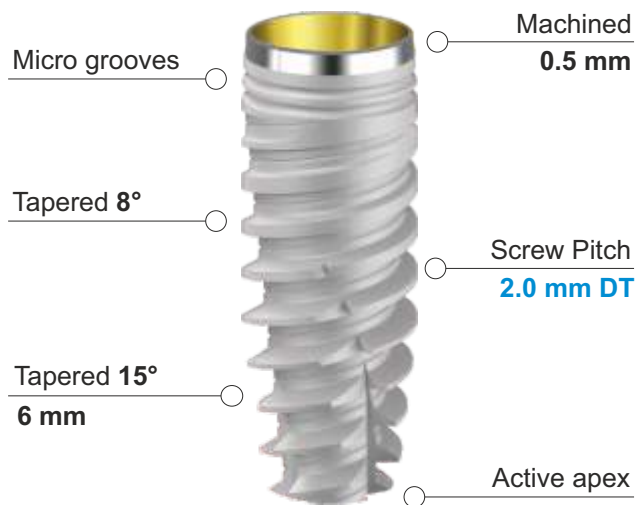

Velocità di rotazione frese consigliata 500 - 800 rpm

Recommended milling burs rotation speed 500 - 800 rpm

IA 50-P

TAPERED SHAPE Conical Connection Internal Hexagon

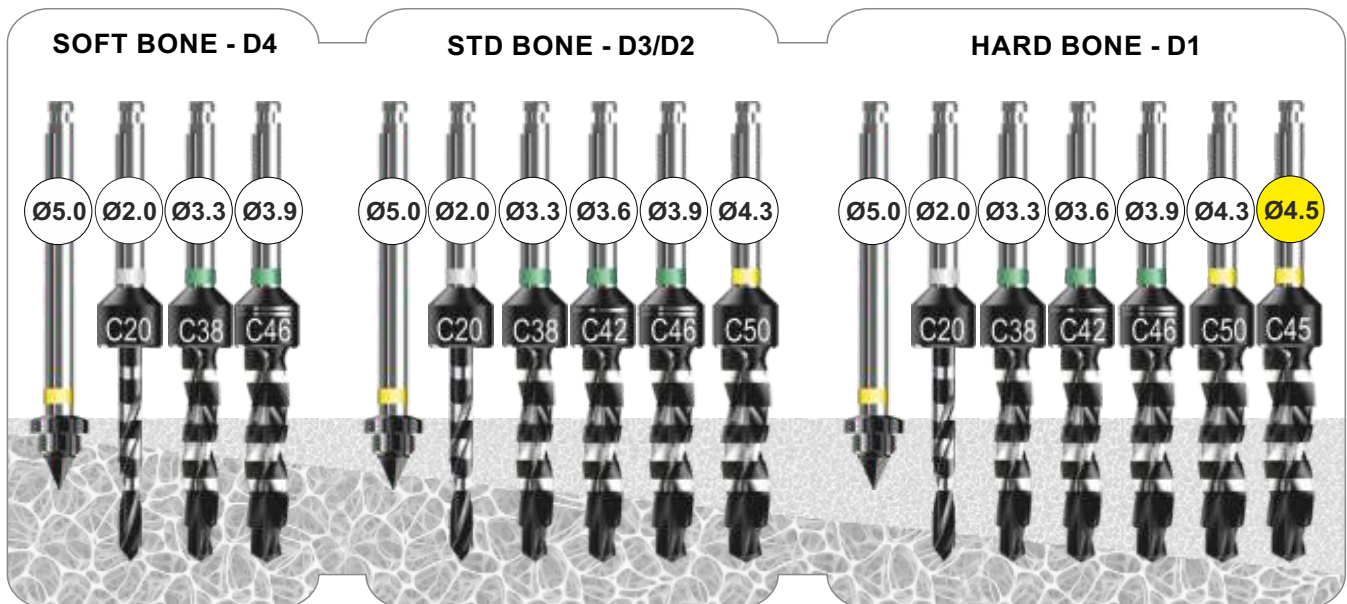
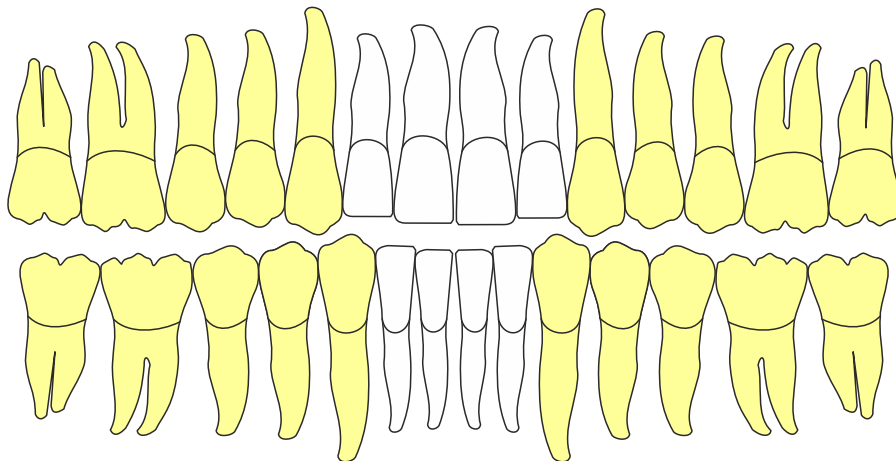
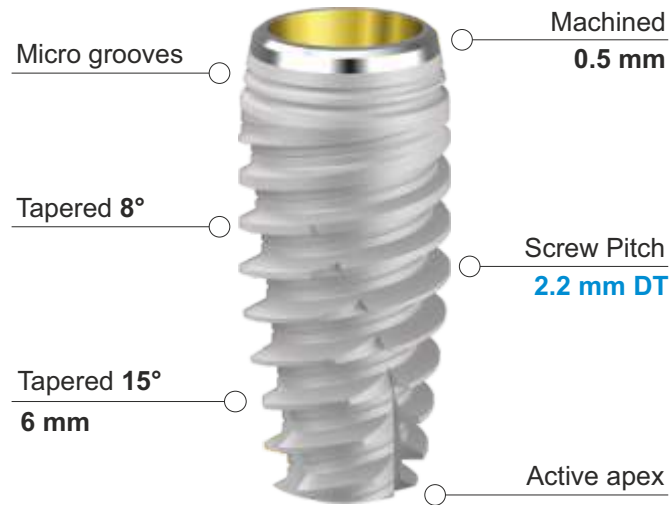

Velocità di rotazione frese consigliata 500 - 800 rpm

Recommended milling burs rotation speed 500 - 800 rpm

4.2 Full Treatment - Mounterless



CODE	IMPLANT	LENGTH	NECK	APEX
IA 4208 P	Ø 4.2	8.5 mm	Ø 4.0	Ø 2.9
IA 4210 P	Ø 4.2	10 mm	Ø 4.0	Ø 2.9
IA 4211 P	Ø 4.2	11.5 mm	Ø 4.0	Ø 2.9
IA 4213 P	Ø 4.2	13 mm	Ø 4.0	Ø 2.9
IA 4215 P	Ø 4.2	15 mm	Ø 4.0	Ø 2.9

5.0 Full Treatment - Mounterless



CODE	IMPLANT	LENGTH	NECK	APEX
IA 5008 P	Ø 5.0	8.5 mm	Ø 4.8	Ø 3.7
IA 5010 P	Ø 5.0	10 mm	Ø 4.8	Ø 3.7
IA 5011 P	Ø 5.0	11.5 mm	Ø 4.8	Ø 3.7
IA 5013 P	Ø 5.0	13 mm	Ø 4.8	Ø 3.7

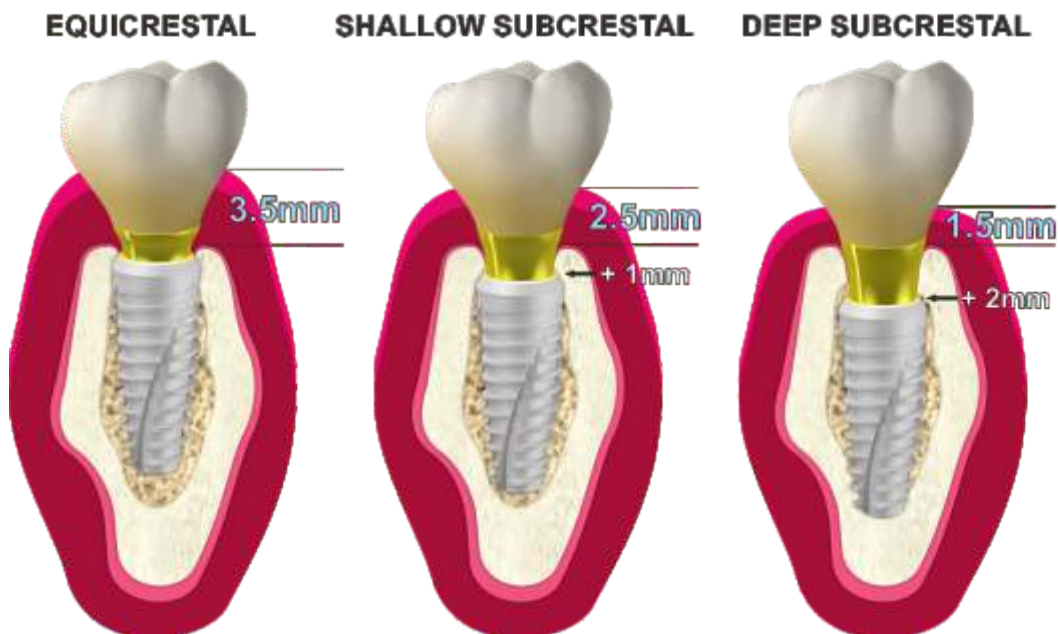

12° CONICAL CONNECTION

REGULAR PLATINUM

SPEEDY
SHAPE



ES-P

ES 42-P

SPEEDY SHAPE
Conical Connection Internal Hexagon

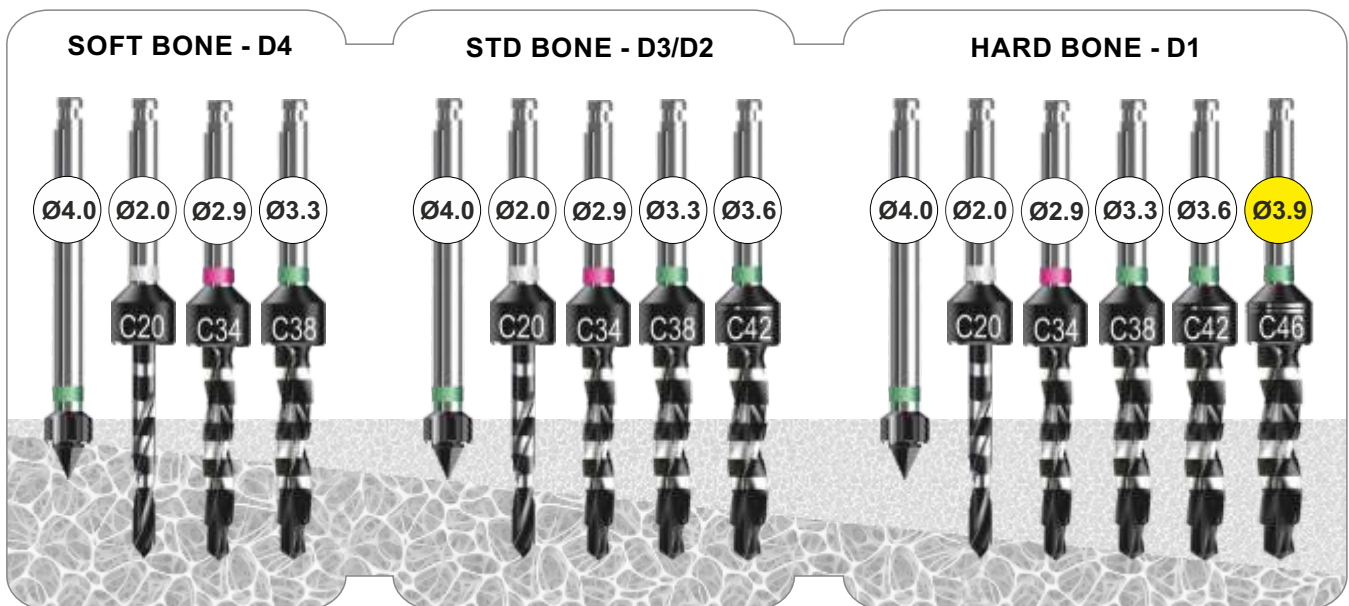
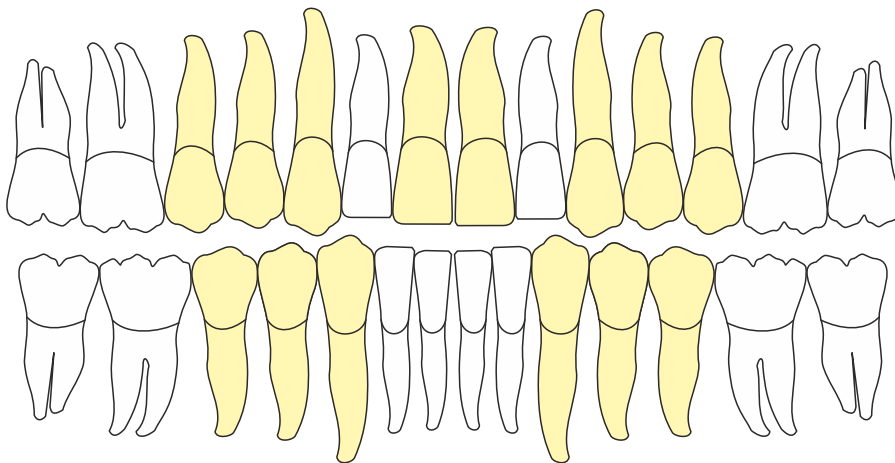
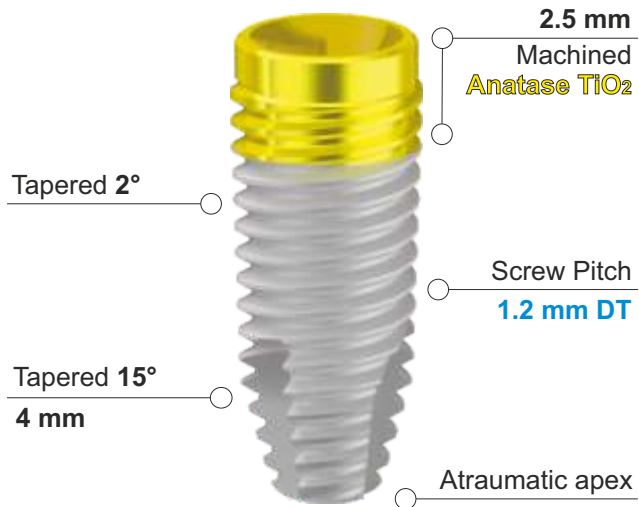

Velocità di rotazione frese consigliata 500 - 800 rpm

Recommended milling burs rotation speed 500 - 800 rpm

ES 50-P

SPEEDY SHAPE
Conical Connection Internal Hexagon

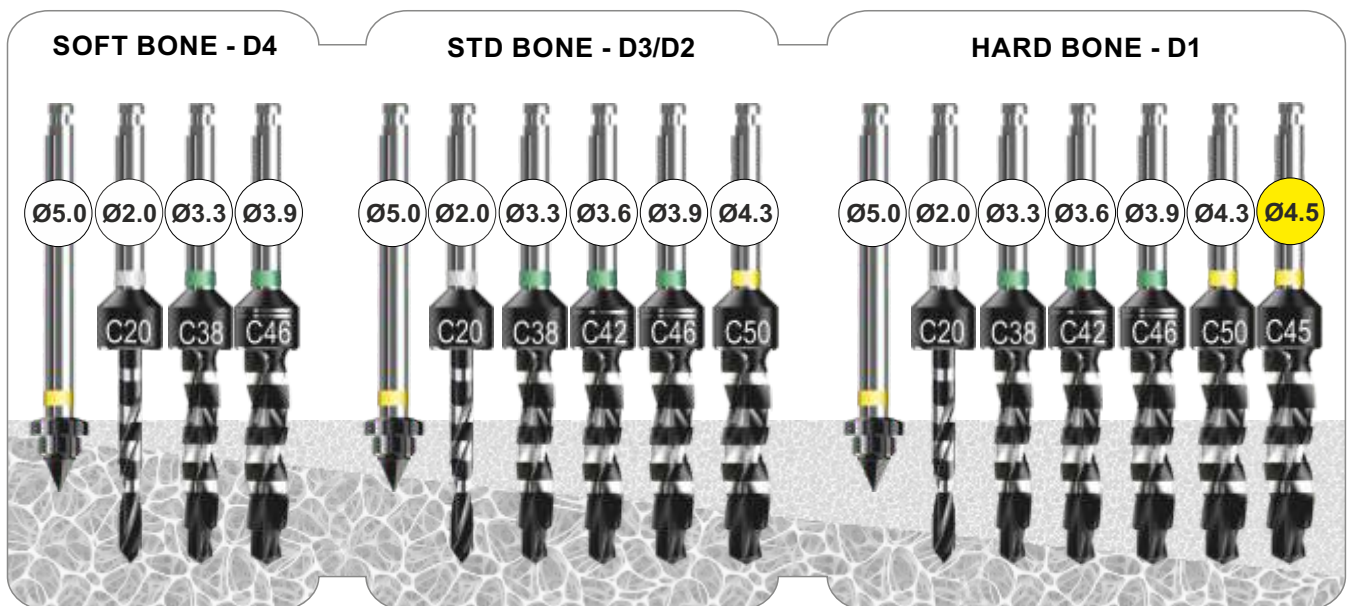
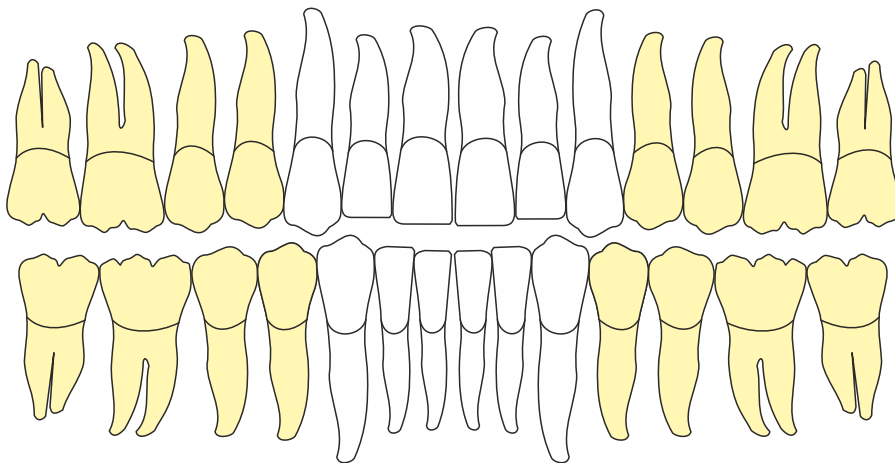
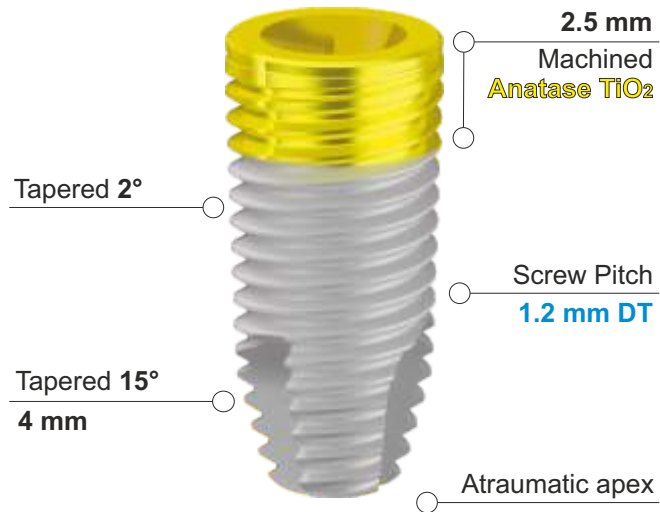

Velocità di rotazione frese consigliata 500 - 800 rpm

Recommended milling burs rotation speed 500 - 800 rpm

4.2 Full Treatment - Mounterless



CODE	IMPLANT	LENGTH	NECK	APEX
ES 4208 P	Ø 4.2	8.5 mm	Ø 4.0	Ø 2.2
ES 4210 P	Ø 4.2	10 mm	Ø 4.0	Ø 2.2
ES 4211 P	Ø 4.2	11.5 mm	Ø 4.0	Ø 2.2
ES 4213 P	Ø 4.2	13 mm	Ø 4.0	Ø 2.2
ES 4215 P	Ø 4.2	15 mm	Ø 4.0	Ø 2.2

5.0 Full Treatment - Mounterless



CODE	IMPLANT	LENGTH	NECK	APEX
ES 5008 P	Ø 5.0	8.5 mm	Ø 4.8	Ø 3.5
ES 5010 P	Ø 5.0	10 mm	Ø 4.8	Ø 3.5
ES 5011 P	Ø 5.0	11.5 mm	Ø 4.8	Ø 3.5
ES 5013 P	Ø 5.0	13 mm	Ø 4.8	Ø 3.5



regular CCP prosthetics

20Ncm 



Pilastro di Guarigione - Titanio Gr. 5 - Anodizzato

Healing Abutment - Titanium Gr. 5 - Anodized

IP 4HA3-P H 3 mm - Regular Gingival Profile

IP 4HA4-P H 4 mm - Regular Gingival Profile

IP 4HA5-P H 5 mm - Regular Gingival Profile

DMX 1/2 Standard Torx Driver



Analogo per Laboratorio - Titanio Gr. 5 - Anodizzato

Laboratory Analog - Titanium Gr. 5 - Anodized

IP 4AL-P H 12 mm - Universal Shape

32Ncm 



Moncone UCLA Cobalto Cromo - CoCr

UCLA Abutment Cobalt Chrome - CoCr

IP 4CCA-P Antirotation Hex - Regular Gingival Profile H1,5mm

IP 4CCR-P Rotating - Regular Gingival Profile H1,5mm

SP VIT40 Vite di Ricambio - Spare Screw

DMX 1/2 Standard Torx Driver

32Ncm 



Moncone Titanio Dritto - Titanio Gr. 5

Straight Titanium Abutment - Titanium Gr. 5

IP 4ST1-P 0° - Straight - Regular Gingival Profile H1.5mm

IP 4ST3-P 0° - Straight - Regular Gingival Profile H3.0mm

IP 4ST4-P 0° - Straight - Regular Gingival Profile H4.0mm

SP VIT40 Vite di Ricambio - Spare Screw

DMX 1/2 Standard Torx Driver

32Ncm 



Moncone Titanio Preangolato 15° - Titanio Gr. 5

15° Angled Titanium Abutment - Titanium Gr. 5

IP 4AT151-P 15° - Angled - Regular Gingival Profile H1.5mm

IP 4AT153-P 15° - Angled - Regular Gingival Profile H3.0mm

IP 4AT154-P 15° - Angled - Regular Gingival Profile H4.0mm

SP VIT40 Vite di Ricambio - Spare Screw

DMX 1/2 Standard Torx Driver

regular CCP prosthetics

Moncone Titanio Preangolato 25° - Titanio Gr. 5

25° Angled Titanium Abutment - Titanium Gr. 5

IP 4AT251-P 25° - Angled - Regular Gingival Profile H1.5mm

IP 4AT253-P 25° - Angled - Regular Gingival Profile H3.0mm

IP 4AT254-P 25° - Angled - Regular Gingival Profile H4.0mm

SP VIT40 Vite di Ricambio - Spare Screw

DMX 1/2 Standard Torx Driver



Pilastro Temporaneo da Incollaggio - Ti Gr. 5

Antirotation Hex Temporary Abutment - Ti Gr. 5

IP 4TA1-P Antirotation Hex - Regular Gingival Profile H 1.5mm

IP 4TA3-P Antirotation Hex - Regular Gingival Profile H 3.0mm

IP 4TR1-P Rotating - Regular Gingival Profile H 1.5mm

IP 4TR3-P Rotating - Regular Gingival Profile H 3.0mm

DMX 1/2 Standard Torx Driver



Pilastro per Overdenture - Titanio Gr. 5 - PVD TiN

Overdenture Abutment - Titanium Gr. 5 - PVD TiN

IP 4BA1-P H 1 mm - Regular Gingival Profile - NORMO

IP 4BA2-P H 2 mm - Regular Gingival Profile - NORMO

IP 4BA3-P H 3 mm - Regular Gingival Profile - NORMO

IP 4BA4-P H 4 mm - Regular Gingival Profile - NORMO

DMX 1/2 Standard Torx Driver



Kit Pilastro Equator per Overdenture - Titanio Gr. 5 - PVD

Overdenture Equator Abutment Kit - Titanium Gr. 5 - PVD

IP 4EQ1-P H 1 mm - Regular Gingival Profile

IP 4EQ2-P H 2 mm - Regular Gingival Profile

IP 4EQ3-P H 3 mm - Regular Gingival Profile

IP 4EQ5-P H 5 mm - Regular Gingival Profile

DM EQ Squared Equator Driver



Transfer per impronta Pick Up - Titanio Gr. 5

Pick Up Impression Coping - Titanium Gr. 5

IP 4IA1-P Regular Gingival Profile - H1.5mm

IP 4IA3-P Regular Gingival Profile - H3.0mm

IP 4IA4-P Regular Gingival Profile - H4.0mm

SP VITL40 Vite di Ricambio - Spare Screw

DMX 1/2 Standard Torx Driver



toronto regular CCP prosthetics

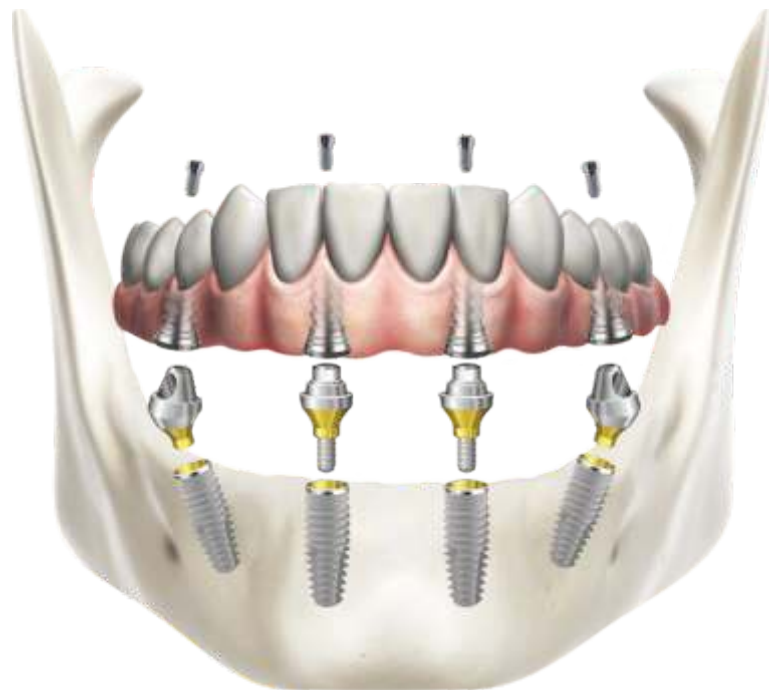

32Ncm



Pilastro Toronto Diritto - Titanio Gr. 5

Toronto Straight Abutment - Titanium Gr. 5

- IP 4MS1-P H 1.5 mm - Standard Gingival Profile
- IP 4MS3-P H 3.0 mm - Standard Gingival Profile
- IP 4MS4-P H 4.0 mm - Standard Gingival Profile

DCDM

Standard Torx Driver

32Ncm



Pilastro Toronto Angolato 17° - Titanio Gr. 5

Toronto 17° Angled Abutment - Titanium Gr. 5

- IP 4MA172-P 17° - H 2 mm - Standard Gingival Profile
- IP 4MA173-P 17° - H 3 mm - Standard Gingival Profile

IP 4VITMA-P Vite di Ricambio Toronto - Toronto Spare Screw

DMX 1/2

Standard Torx Driver

32Ncm



Pilastro Toronto Angolato 30° - Titanio Gr. 5

Toronto 30° Angled Abutment - Titanium Gr. 5

- IP 4MA303-P 30° - H 3 mm - Standard Gingival Profile
- IP 4MA304-P 30° - H 4 mm - Standard Gingival Profile

IP 4VITMA-P Vite di Ricambio Toronto - Toronto Spare Screw

DMX 1/2

Standard Torx Driver

toronto regular CCP prosthetics

Pilastro Calcinabile Toronto & Pilastro di Guarigione

Toronto Castable Abutment & Healing Abutment

- EP MC** Rotating Castable Abutment
- EP MHA** H 4 mm - Standard Gingival Profile Titanium Gr5
- EP MHA6** H 6 mm - Large Gingival Profile Titanium Gr5
- EP MV** Vite di Ricambio Toronto - Toronto Spare Screw
- DMX 1/2** Standard Torx Driver



Componenti Protesiche Toronto - Titanio Gr. 5

Toronto Prosthetics - Titanium Gr. 5

- EP MI** Rotating - Standard Gingival Profile
- EP MAL2DS** Digital Toronto Analog - Analogo Digitale
- EP MT** Rotating Temporary - Incollaggio Passivo
- EP MTS** Rotating Welding Temporary - Saldatura Intraorale
- EP MVL** Vite di Ricambio Lunga - Long Spare Screw
- DMX 1/2** Standard Torx Driver



Transfer Toronto & Link da Incollaggio - Titanio Gr. 5

Toronto Scan Abutment & Link - Titanium Gr. 5

- EP MSA2 DS** Toronto Rotating Scan Abutment
- EP MT DS** Toronto Rotating - Bonding Technique Link
- EP MV** Vite di Ricambio Toronto - Toronto Spare Screw
- DMX 1/2** Standard Torx Driver

Digital Solutions



Componenti Digitali CCP - Titanio Gr. 5

CCP Digital Components - Titanium Gr. 5

- ACT SB43K** Antirotational Scan Abutment
- ACT LKN43K** Antirotational Bonding Technique Link
- ACT LKR43K** Rotating Bonding Technique Link
- ACT AN3D43K** CAD Laboratory Analog
- ACT VP** Vite di Ricambio - Spare Screw
- DMX 1/2** Standard Torx Driver





UNI-Q-MUA

ONE PIECE TRANSGINGIVAL IMPLANT

UNI-Q-MUA
TAPERED SHAPE



MMF

UNI-Q-MUA

3 TREATMENT SURFACE



PVD TiN



Machined

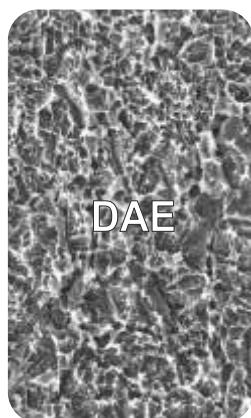

DAE



DAE

Bone healing around titanium and titanium nitride-coated dental implants with three surfaces: an experimental study in rats. Scarano A, Piattelli M, Vrespa G, Petrone G, Iezzi G, Piattelli A. - Clin Implant Dent Relat Res. 2003

Bacterial adhesion on titanium nitride-coated and uncoated implants: an in vivo human study. Scarano A, Piattelli M, Vrespa G, Caputi S, Piattelli A. - J Oral Implant. 2003

Cytocompatibility of implants coated with titanium nitride and zirconium nitride. Prachar P, Bartakova S, Brezina V, Cvrcek L, Vanek J. - Bratisl Lek Listy. 2015

Evaluation of antibacterial activity and osteoblast-like cell viability of TiN, ZrN and (Ti1-xZrx)N coating on titanium. Ji MK, Park SW, Lee K, Kang IC, Yun KD, Kim HS, Lim Hp. - J Adv Prosthodont. 2015

Surface properties correlated with the human gingival fibroblasts attachment on various materials for implant abutments: a multiple regression analysis. Kim YS1, Shin SY, Moon SK, Yang SM. - Acta Odontol Scand. 2015

Machined and sandblasted human dental implants retrieved after 5 years: a histologic and histomorphometric analysis of three cases. Iezzi G, Vantaggiato G, Shibli JA, Fiera E, Falco A, Piattelli A, Perrotti V. - Quintessence Int. 2012

Polyspecies biofilm formation on implant surfaces with different surface characteristics. Schmidlin PR, Müller P, Attin T, Wieland M, Hofer D, Guggenheim B. - J Appl Oral Sci. 2013

Red blood cell and platelet interactions with titanium implant surfaces. Park JY, Davies JE. - Clin Oral Implants Res. 2000

Surface chemistry effects of topographic modification of titanium dental implant surfaces. 2: In vitro experiments. Morra M, Cassinelli C, Bruzzone G, et al. - Int J Oral and Maxillofac Implants 2003

Surface microtopography regulates osteointegration: the role of implant surface microtopography in osteointegration. Schwartz Z1, Nasazky E, Boyan BD. - 2005

A new chemical etching process to improve endosseous implant osseointegration: in vitro evaluation on human osteoblast-like cells. Giordano C, Sandrini E, Busini V, Chiesa R, Furnagalli G, Giavaresi G, Fini M, Giardino R, Cigada A. - Int J Artif Organs. 2006

Enhancing surface free energy and hydrophilicity through chemical modification of microstructured titanium implant surfaces. Morra M, Volpe CD, Siboni S, by F. Rupp, L. Scheideler, N. Olshanska, M. de Wild, M. Wieland, J. Geis-Gerstorf. - J Biomed Mater Res A. 2006

Assessing double Acid-etched implants submitted to orthodontic forces and used as prosthetic anchorages in partially edentulous patients. De Cravero Marta R1, Carlos IJ. - Open Dent J. 2008.

Mechanical stability of immediately loaded implants with various surfaces and designs: a pilot study in dogs. Neugebauer J, Weinländer M, Lekovic V, von Berg KH, Zoeller JE. Int J Oral Maxillofac Implants. 2009

Influence of implant shape, surface morphology, surgical technique and bone quality on the primary stability of dental implants. Elias CN1, Rocha FA, Nascimento AL, Coelho PG. - J Mech Behav Biomed Mater. 2012

Early-loaded laser-sintered versus acid-etched one-piece dental implants for mandibular premolars replacement: a preliminary study. El-Gammal M1, Ghoneem N, Tawfik H, Madina MA, Fadhil ON, Maria OM. Implant Dent. 2014

Dual-etched implants loaded after 1- and 2-month healing periods: a histologic comparison in baboons. Vermino AR, Kohles SS, Holt RA Jr, Lee HM, Caudill RF, Kenealy JN. Int J Periodontics Restorative Dent 2002

Early endosseous integration enhanced by dual acid etching of titanium: a torque removal study in the rabbit. Klokkevold P, Johnson P, Dadgostari S, Caputo A, Davies JE, Nishimura R. Clin Oral Implants Res 2001

3 TRATTAMENTI DI SUPERFICIE

1) Rivestimento transgingivale e protesico in PVD TiN - *Maggiore resistenza meccanica all'usura, proprietà antibatteriche, riduzione dell'adesione del biofilm batterico.*

2) Superficie Ibrida Macchinata per 1.5mm - *Riduzione dell'adesione del biofilm batterico per il controllo delle perimplantiti.*

3) Superficie Doppia Acidificazione DAE - *Incremento della superficie, rimozione dei microdifetti ed uniformazione, incremento dell'idrofilia superficiale, incremento dell'adesione dei ponti di fibrina, idealizzazione del substrato per l'adesione cellulare, attivazione della comunicazione topografica per l'espressione genica cellulare/osteoblastica, incremento dell'attività antibatterica bio-elettrica.*

UNI-Q-MUA

TORONTO PROSTHETICS - BRIDGES AND CROWNS

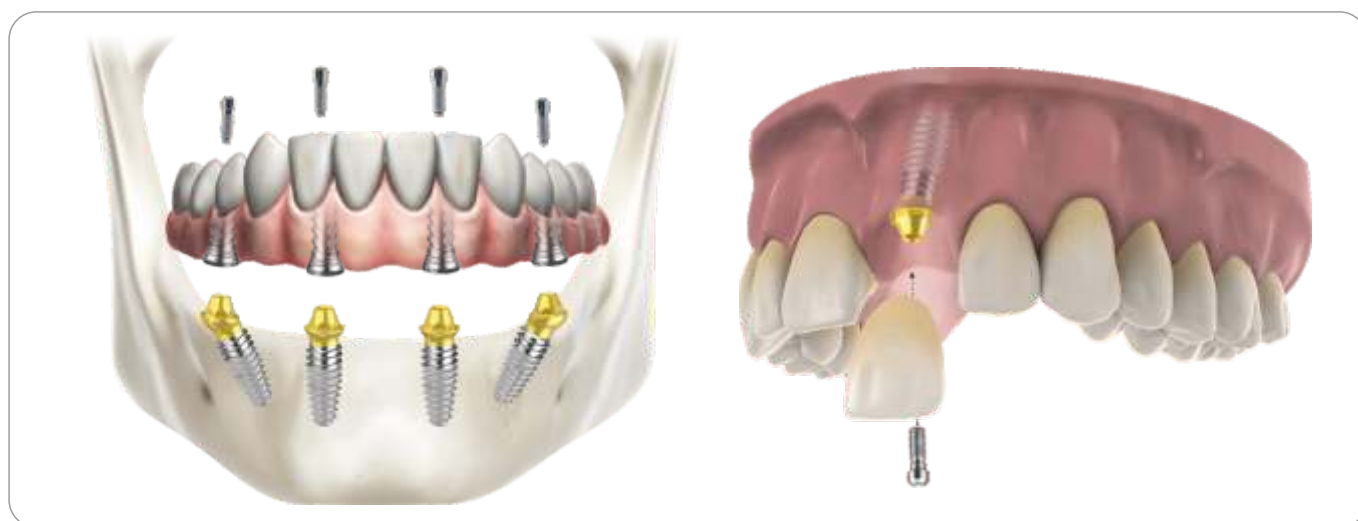

UNI-Q-MUA 2.0

Evoluzione del progetto originale UNI-Q-MUA del 2015, sviluppato e migliorato dal nostro reparto di R&D per un applicazione chirurgica a 360°.

Nato per la realizzazione e semplificazione della protesi tipo Toronto, allarga il suo campo di applicazione alle corone e ponti. Con un collo trans-gengivale di 1,5mm ed una piattaforma protesica anti-rotazionale esagonale, permette il serraggio diretto anche di una singola corona avvitata.

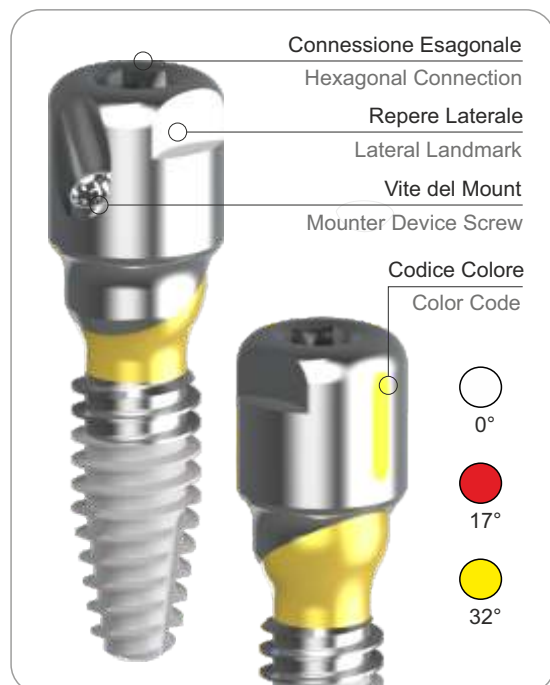

UNI-Q-MUA 2.0

Born for the Toronto-type prosthetics realization and simplification, it extends its application field to crowns and bridges. With a 1.5mm trans-gingival neck and a hexagonal anti-rotational prosthetic platform, it allows direct tightening of even a single screwed crown.

UNI-Q-MUA 34

ONE PIECE TRANSGINGIVAL IMPLANT

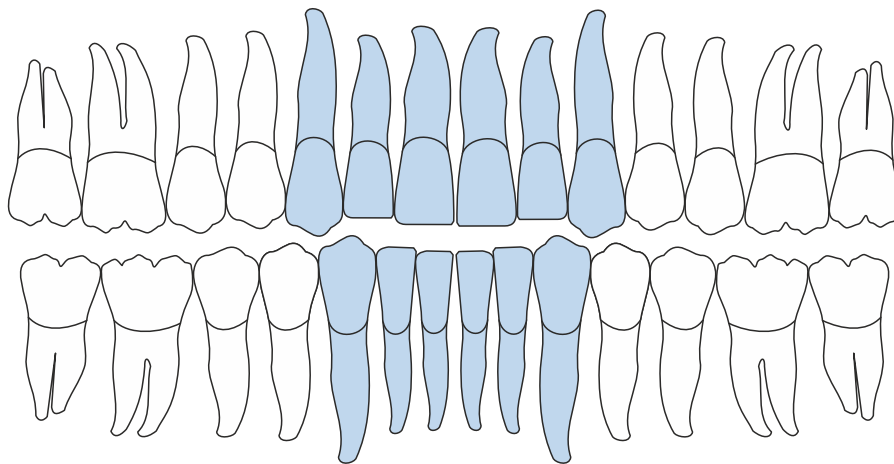
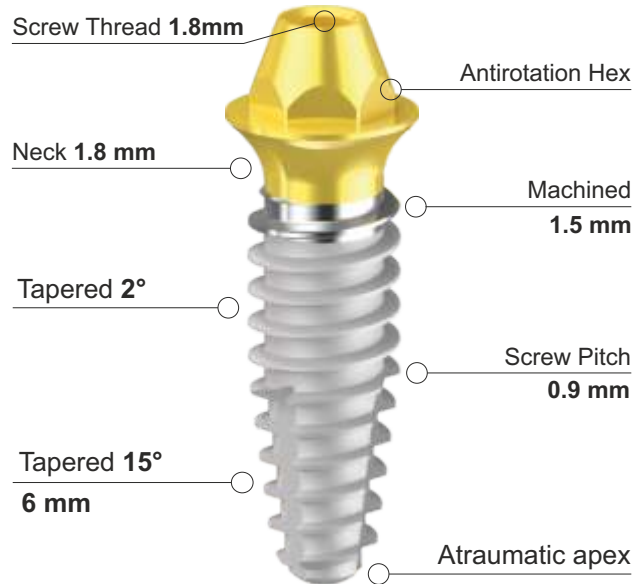

SOFT BONE - D4



STD BONE - D3/D2



HARD BONE - D1



Velocità di rotazione frese consigliata 500 - 800 rpm

Recommended milling burs rotation speed 500 - 800 rpm

3.4 Straight 0° Half Treatment - With Moulder



CODE	IMPLANT	LENGTH	NEK	ANGLE	APEX
MMFS 3408	Ø 3.4	8.5 mm	4.4 mm	0° ○	Ø 1.8
MMFS 3410	Ø 3.4	10 mm	4.4 mm	0° ○	Ø 1.8
MMFS 3411	Ø 3.4	11.5 mm	4.4 mm	0° ○	Ø 1.8
MMFS 3413	Ø 3.4	13 mm	4.4 mm	0° ○	Ø 1.8

3.4 Angled 17° Half Treatment - With Moulder



CODE	IMPLANT	LENGTH	NEK	ANGLE	APEX
MMFA 3408-17	Ø 3.4	8.5 mm	4.4 mm	17° ●	Ø 1.8
MMFA 3410-17	Ø 3.4	10 mm	4.4 mm	17° ●	Ø 1.8
MMFA 3411-17	Ø 3.4	11.5 mm	4.4 mm	17° ●	Ø 1.8
MMFA 3413-17	Ø 3.4	13 mm	4.4 mm	17° ●	Ø 1.8
MMFA 3415-17	Ø 3.4	15 mm	4.4 mm	17° ●	Ø 1.8

3.4 Angled 32° Half Treatment - With Moulder



CODE	IMPLANT	LENGTH	NEK	ANGLE	APEX
MMFA 3408-32	Ø 3.4	8.5 mm	4.4 mm	32° ●	Ø 1.8
MMFA 3410-32	Ø 3.4	10 mm	4.4 mm	32° ●	Ø 1.8
MMFA 3411-32	Ø 3.4	11.5 mm	4.4 mm	32° ●	Ø 1.8
MMFA 3413-32	Ø 3.4	13 mm	4.4 mm	32° ●	Ø 1.8
MMFA 3415-32	Ø 3.4	15 mm	4.4 mm	32° ●	Ø 1.8

UNI-Q-MUA 38

ONE PIECE TRANSGINGIVAL IMPLANT

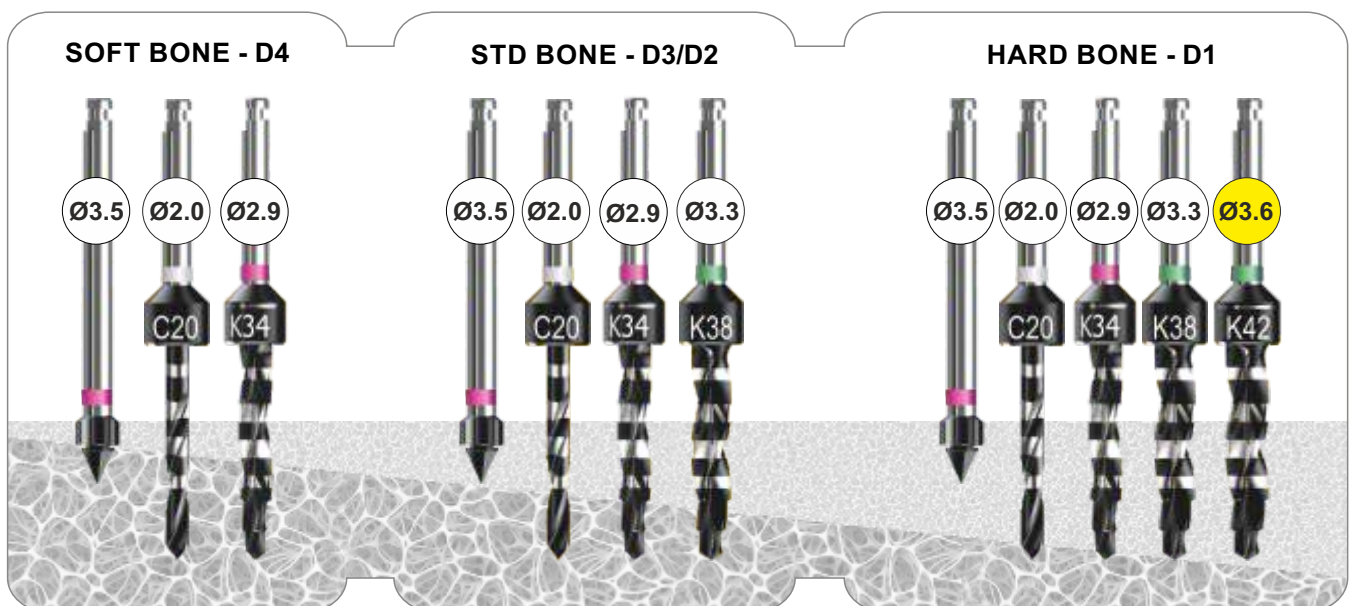
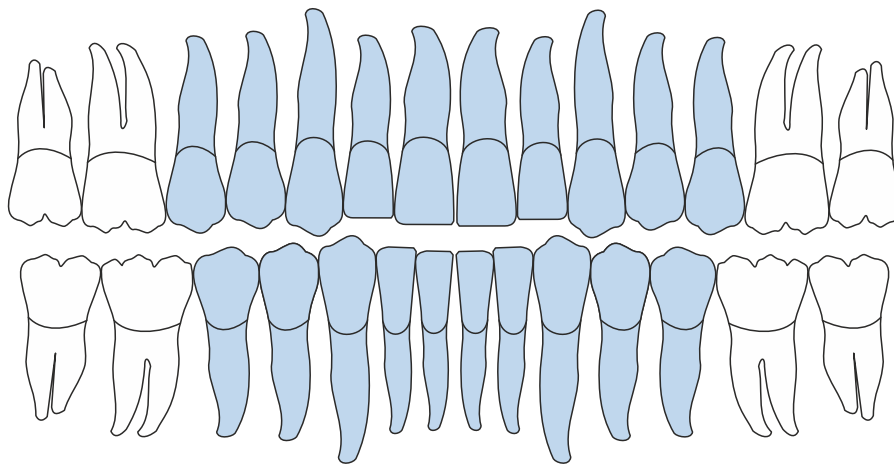
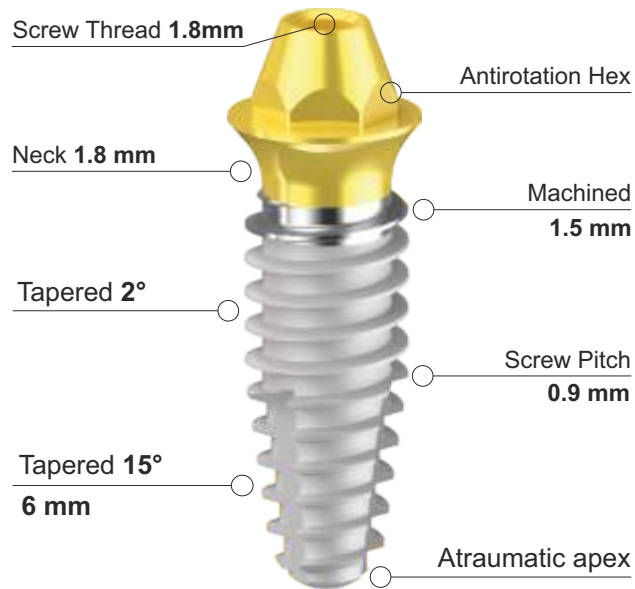

Velocità di rotazione frese consigliata 500 - 800 rpm

Recommended milling burs rotation speed 500 - 800 rpm

3.8 Straight 0° Half Treatment - With Moulder



CODE	IMPLANT	LENGTH	NEK	ANGLE	APEX
MMFS 3808	Ø 3.8	8.5 mm	4.4 mm	0° ○	Ø 1.9
MMFS 3810	Ø 3.8	10 mm	4.4 mm	0° ○	Ø 1.9
MMFS 3811	Ø 3.8	11.5 mm	4.4 mm	0° ○	Ø 1.9
MMFS 3813	Ø 3.8	13 mm	4.4 mm	0° ○	Ø 1.9

3.8 Angled 17° Half Treatment - With Moulder



CODE	IMPLANT	LENGTH	NEK	ANGLE	APEX
MMFA 3808-17	Ø 3.8	8.5 mm	4.4 mm	17° ●	Ø 1.9
MMFA 3810-17	Ø 3.8	10 mm	4.4 mm	17° ●	Ø 1.9
MMFA 3811-17	Ø 3.8	11.5 mm	4.4 mm	17° ●	Ø 1.9
MMFA 3813-17	Ø 3.8	13 mm	4.4 mm	17° ●	Ø 1.9
MMFA 3815-17	Ø 3.8	15 mm	4.4 mm	17° ●	Ø 1.9
MMFA 3818-17	Ø 3.8	18 mm	4.4 mm	17° ●	Ø 1.9
MMFA 3820-17	Ø 3.8	20 mm	4.4 mm	17° ●	Ø 1.9
MMFA 3822-17	Ø 3.8	22 mm	4.4 mm	17° ●	Ø 1.9

3.8 Angled 32° Half Treatment - With Moulder



CODE	IMPLANT	LENGTH	NEK	ANGLE	APEX
MMFA 3808-32	Ø 3.8	8.5 mm	4.4 mm	32° ●	Ø 1.9
MMFA 3810-32	Ø 3.8	10 mm	4.4 mm	32° ●	Ø 1.9
MMFA 3811-32	Ø 3.8	11.5 mm	4.4 mm	32° ●	Ø 1.9
MMFA 3813-32	Ø 3.8	13 mm	4.4 mm	32° ●	Ø 1.9
MMFA 3815-32	Ø 3.8	15 mm	4.4 mm	32° ●	Ø 1.9
MMFA 3818-32	Ø 3.8	18 mm	4.4 mm	32° ●	Ø 1.9
MMFA 3820-32	Ø 3.8	20 mm	4.4 mm	32° ●	Ø 1.9
MMFA 3822-32	Ø 3.8	22 mm	4.4 mm	32° ●	Ø 1.9

UNI-Q-MUA 42

ONE PIECE TRANSGINGIVAL IMPLANT

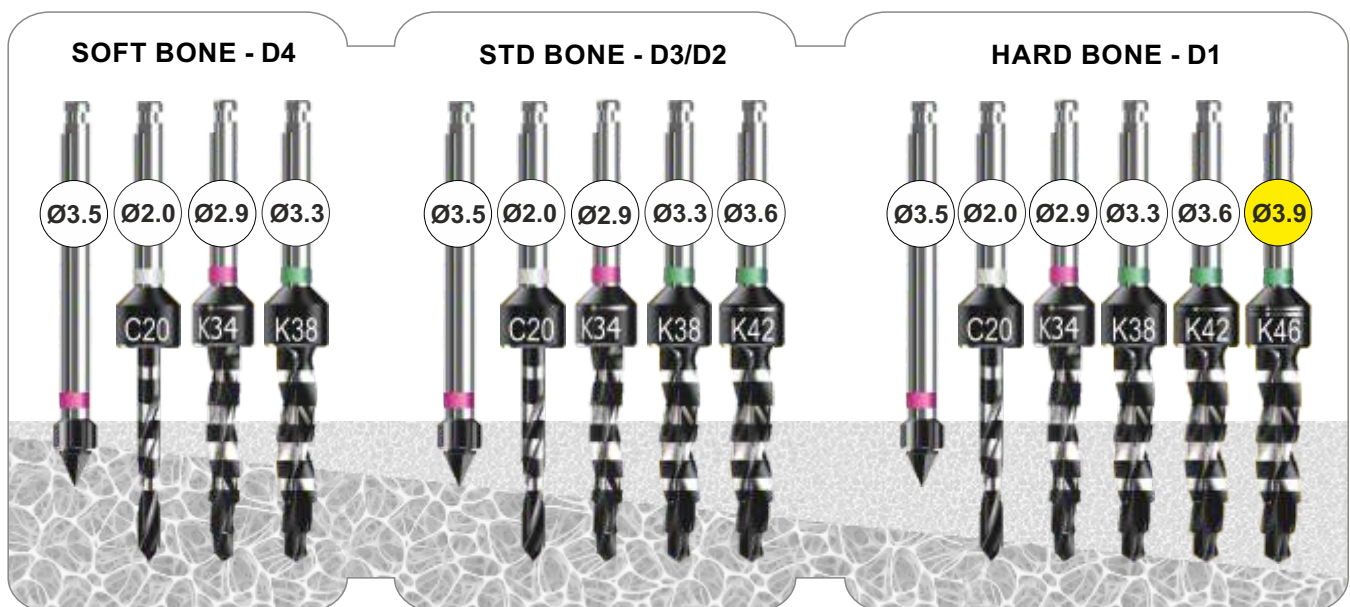
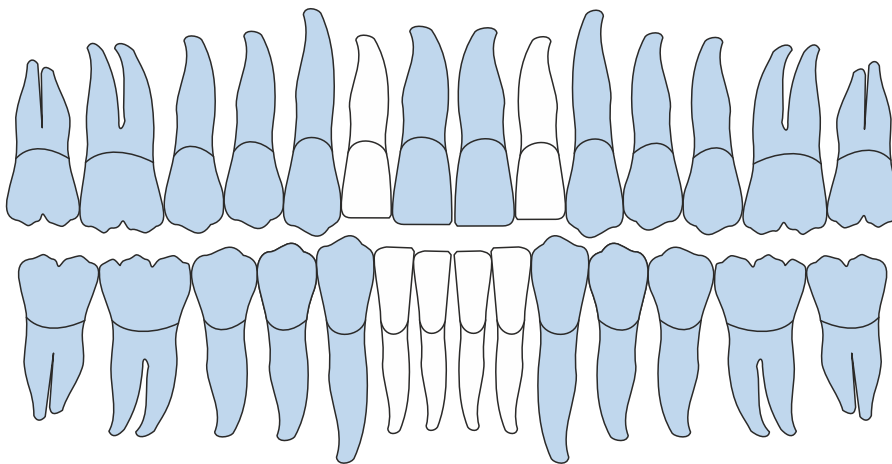
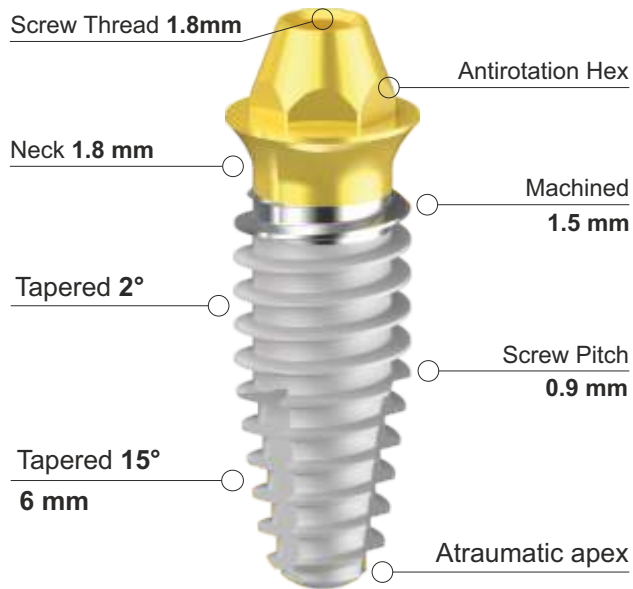
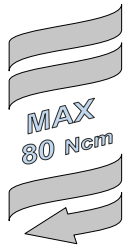

Velocità di rotazione frese consigliata 500 - 800 rpm

Recommended milling burs rotation speed 500 - 800 rpm

4.2 Straight 0° Half Treatment - With Mouter



CODE	IMPLANT	LENGTH	NEK	ANGLE	APEX
MMFS 4208	Ø 4.3	8.5 mm	4.4 mm	0° ○	Ø 2.3
MMFS 4210	Ø 4.3	10 mm	4.4 mm	0° ○	Ø 2.3
MMFS 4211	Ø 4.3	11.5 mm	4.4 mm	0° ○	Ø 2.3
MMFS 4213	Ø 4.3	13 mm	4.4 mm	0° ○	Ø 2.3

4.2 Angled 17° Half Treatment - With Mouter



CODE	IMPLANT	LENGTH	NEK	ANGLE	APEX
MMFA 4208-17	Ø 4.3	8.5 mm	4.4 mm	17° ●	Ø 2.3
MMFA 4210-17	Ø 4.3	10 mm	4.4 mm	17° ●	Ø 2.3
MMFA 4211-17	Ø 4.3	11.5 mm	4.4 mm	17° ●	Ø 2.3
MMFA 4213-17	Ø 4.3	13 mm	4.4 mm	17° ●	Ø 2.3
MMFA 4215-17	Ø 4.3	15 mm	4.4 mm	17° ●	Ø 2.3

4.2 Angled 32° Half Treatment - With Mouter



CODE	IMPLANT	LENGTH	NEK	ANGLE	APEX
MMFA 4208-32	Ø 4.3	8.5 mm	4.4 mm	32° ●	Ø 2.3
MMFA 4210-32	Ø 4.3	10 mm	4.4 mm	32° ●	Ø 2.3
MMFA 4211-32	Ø 4.3	11.5 mm	4.4 mm	32° ●	Ø 2.3
MMFA 4213-32	Ø 4.3	13 mm	4.4 mm	32° ●	Ø 2.3
MMFA 4215-32	Ø 4.3	15 mm	4.4 mm	32° ●	Ø 2.3

UNI-Q-MUA surgical tools - prosthetics



KIT Q
Kit Base UNI-Q-MUA
BOX 02 + 7 Frese + 16 Accessori

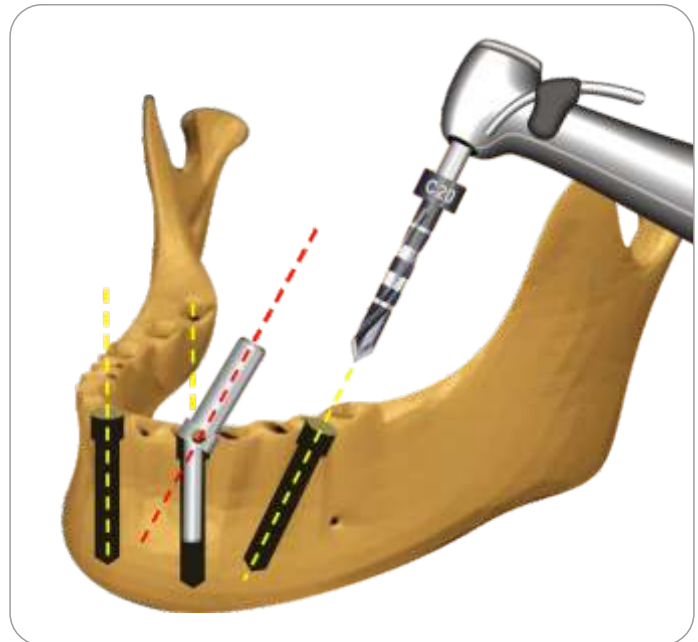

32° 17° 0°



PIN-Q



Perni di Parallelismo Chirurgici - Titanio Gr. 5

Paralleling Pins - Titanium Gr. 5

- PIN** Double diameter - 1.8mm / 3mm - 0°
- PIN17** Double diameter - 1.8mm / 3mm - 17°
- PIN32** Double diameter - 1.8mm / 3mm - 32°
- PIN-Q** Peek Pin for Parallelism Control

20Ncm



Pilastro di Guarigione UNI-Q-MUA - PE

UNI-Q-MUA Healing Abutment - PE

- EP MHA-Q** H 5 mm - Standard Gingival Profile
- EP MHA7-Q** H 7 mm - Standard Gingival Profile

DMX 1/2 Standard Torx Driver

20Ncm



Pilastro Calcinabile UNI-Q-MUA - Acrilico

UNI-Q-MUA Castable Abutment - Acrylic

- EP MC-Q** Rotating - Standard Gingival Profile

EP MV-Q Vite di Ricambio Q - Q Spare Screw
DMX 1/2 Standard Torx Driver

UNI-Q-MUA surgical tools - prosthetics

Transfer e Analogo UNI-Q-MUA - Titanio Gr. 5

UNI-Q-MUA Impression Coping and Analog - Titanium Gr. 5

EP MALQ2DS-V Analog H 10 mm - Universal Shape

EP MI-Q Rotating Transfer

EP MIA-Q Antirotation Hex Transfer

EP MVL-Q Vite di Ricambio Q - Q Spare Screw

DMX 1/2 Standard Torx Driver



Pilastro Temporaneo UNI-Q-MUA - Titanio Gr. 5

UNI-Q-MUA Temporary Abutment - Titanium Gr. 5

EP MT-Q Rotating Bonding Technique - Incollaggio Passivo

EP MTS-Q Rotating Welding Technique - Saldatura Intraorale

EP MV-Q Vite di Ricambio Q - Q Spare Screw

DMX 1/2 Standard Torx Driver



Pilastro Base CoCr Antirotazione - CoCr

Antirotational CoCr Base Abutment - CoCr

EP MCCA-Q Antirotation Hex - Standard Gingival Profile

Intervallo di Fusione 1350°-1430°

Espansione Termica 13,3 - 13,6 $\mu\text{m}/(\text{m}^{\circ}\text{C})$ (20°-200°)

EP MV-Q Vite di Ricambio Q - Q Spare Screw

DMX 1/2 Standard Torx Driver



Componenti Digitali UNI-Q-MUA - Titanio Gr. 5

UNI-Q-MUA Digital Components - Titanium Gr. 5

EP MSAQ2 DS Antirotational Scan Abutment

EP MTAQ DS Antirotational Bonding Technique Base Link

EP MTRQ DS Rotating Bonding Technique Base Link

EP MALQ2DS CAD Laboratory Analog

EP MV-Q Vite di Ricambio Q - Q Spare Screw

DMX 1/2 Standard Torx Driver

Digital Solutions

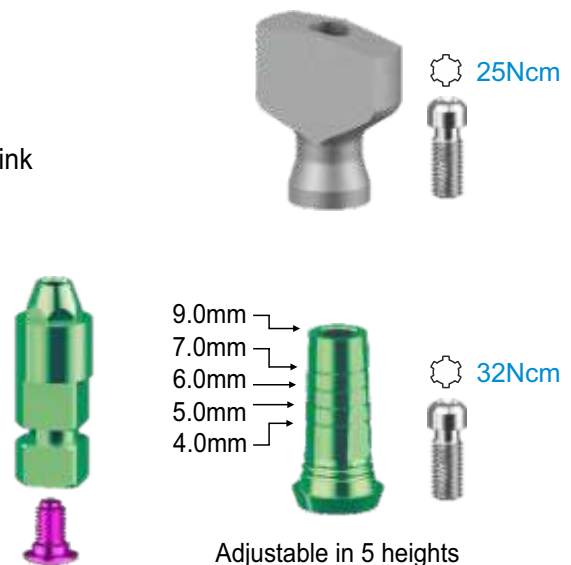



MICRO IMPLANTS

ONE PIECE TRANSGINGIVAL IMPLANT

MICRO SFERA - MONCONE CYLINDRICAL SHAPE



MS

MM

M 27

ONE PIECE TRANSGINGIVAL IMPLANT

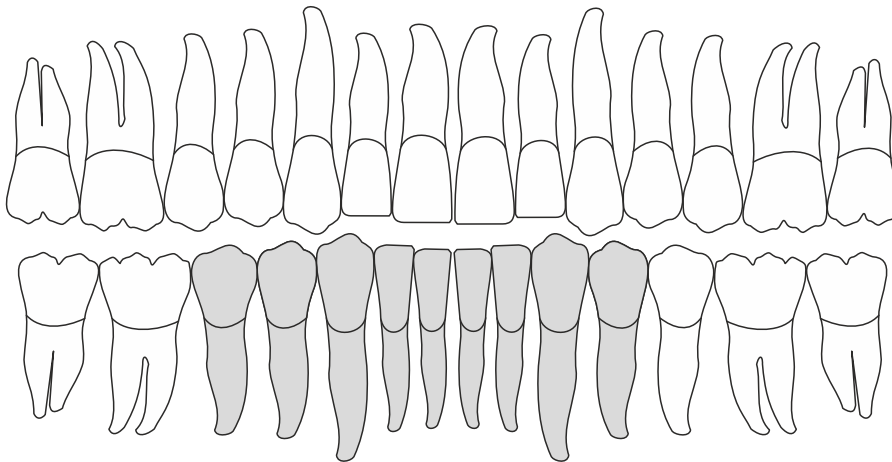
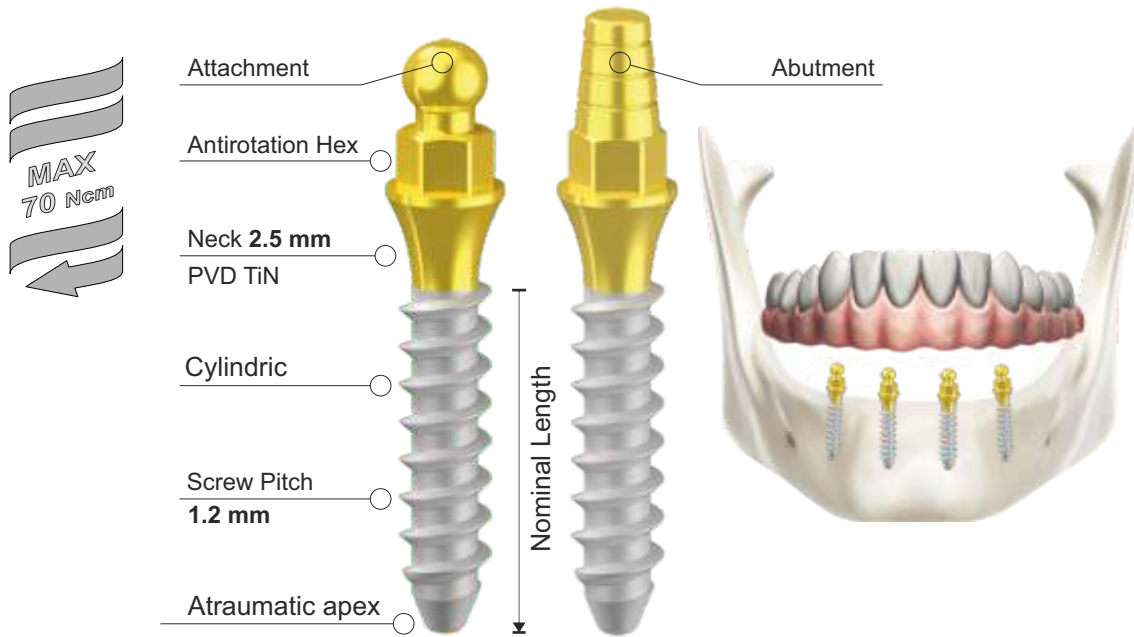

COLLO EMERGENTE - EMERGING NECK

COLLO SOMMERSO - SUBMERGED NECK

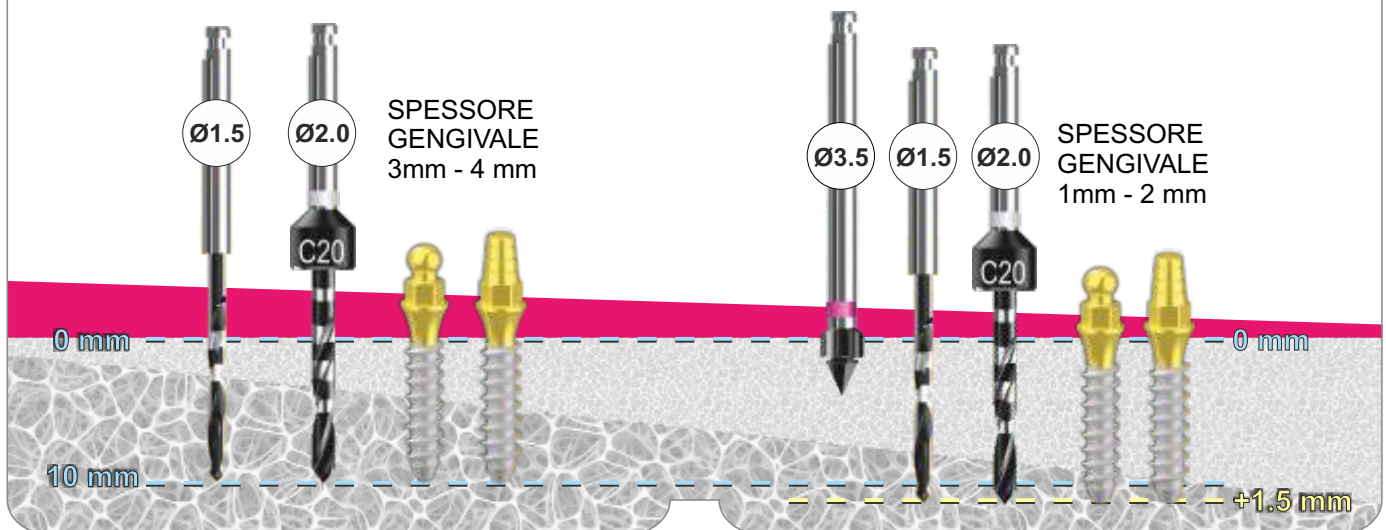

Velocità di rotazione frese consigliata 500 - 800 rpm

Recommended milling burs rotation speed 500 - 800 rpm

2.7 Straight 0° Half Treatment - With Mounter



CODE	IMPLANT	LENGTH	NECK	TYPE
MS 2710	Ø 2.7	10 mm	Ø 3.5	Sfera NORMO
MS 2711	Ø 2.7	11.5 mm	Ø 3.5	Sfera NORMO
MS 2713	Ø 2.7	13 mm	Ø 3.5	Sfera NORMO
MSM 2710	Ø 2.7	10 mm	Ø 3.5	Sfera MICRO
MSM 2711	Ø 2.7	11.5 mm	Ø 3.5	Sfera MICRO
MSM 2713	Ø 2.7	13 mm	Ø 3.5	Sfera MICRO

2.7 Straight 0° Half Treatment - With Mounter



CODE	IMPLANT	LENGTH	NECK	TYPE
MM 2710	Ø 2.7	10 mm	Ø 3.5	Moncone
MM 2711	Ø 2.7	11.5 mm	Ø 3.5	Moncone
MM 2713	Ø 2.7	13 mm	Ø 3.5	Moncone

Protesica per Mini Implants - Titanio Gr 5

Mini Implants Prosthetic Parts - Titanium Gr. 5

PM SN Normo 2.5mm - Laboratory Analogue

PM SM Micro 1.8mm - Laboratory Analogue

PM M Abutment - Laboratory Analogue

PM C Castable - Universal Abutment

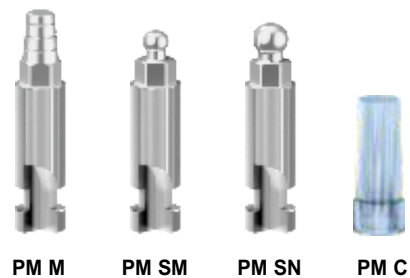

Strumentario per Mini Implants

Mini Implants Instruments

FIS 35 Cortical Drill - Ø 3.5 mm

FG P15 Pins Drill - Ø 1.5 mm

FCS 20 Cylindrical Drill - Ø 2.0 mm - Long 18 mm

PCM Cricchetto - Ratchet **Mini Implant Driver**

ACM Contrangolo - Contrangle **Mini Implant Driver**





SPARE SCREWS & MOUNTERS

REPLACEMENT PRODUCTS

SCREWS & MOUNTERS





























spare screws

ESAGONO INTERNO IK / IA / IC - INTERNAL HEXAGON IK / IA / IC

IP VIT20	H 20mm Transfer Screw - Ø 1.8mm	25Ncm		
IP VIT30	H 30mm Transfer Screw - Ø 1.8mm	25Ncm		
IP VIT	H 8mm Prosthetic Screw - Ø 1.8mm	32Ncm		
IP VITG	H 8mm Prosthetic Screw - Ø 1.8mm - Gold PVD TiN	32Ncm		
IP VITT6DS	Prosthetic Screw T6 per Avvitamento Angolato - Ø 1.8mm	20Ncm		
IP VITMA	Angled 17°/30° MUA Abutment Screw - Ø 1.8mm	32Ncm		
IP 2VITT6DS	K-NARROW Screw T6 per Avvitamento Angolato - Ø 1.6mm	20Ncm		

ESAGONO ESTERNO ES / EC / EK - EXTERNAL HEXAGON ES / EC / EK

















EP VIT20	H 20mm Transfer Screw - Ø 2.0mm	25Ncm		
EP VIT30	H 30mm Transfer Screw - Ø 2.0mm	25Ncm		
EP VIT	H 8mm Prosthetic Screw - Ø 2.0mm	32Ncm		
EP VITG	H 8mm Prosthetic Screw - Ø 2.0mm- Gold PVD TiN	32Ncm		
EP VITT6DS	Prosthetic Screw T6 per Avvitamento Angolato - Ø 2.0mm	20Ncm		
EP VITMA	Angled 17°/30° MUA Abutment Screw - Ø 2.0mm	32Ncm		
EP MV	Toronto Prosthetic Spare Screw - Ø 1.4mm	15Ncm		
TIVPMAI	Toronto Prosthetic Screw T6 Avvitamento Ang. - Ø 1.4mm	15Ncm		
EP MVL	Toronto Impression Spare Screw - Ø 1.4mm	15Ncm		
EP VITS	H 8mm CAD CAM Screw - Ø 2mm Torque Gold	32Ncm		
EP VITB	H 8mm - Ø 2mm External Hexagon - Torque Black DLC	32Ncm		
SP VIT40	H 8mm Prosthetic Screw - Ø 2.0mm ●	32Ncm		
SP VIT33	H 8mm Prosthetic Screw - Ø 1.6mm ●	25Ncm		
SP VIT50	H 8mm Prosthetic Screw - Ø 2.5mm ●	35Ncm		

spare screws

12° PLATINUM CONICAL CONNECTION IK-P / IA-P / ES-P

IP VIT3L-P	H 20mm NARROW Transfer Screw - Ø 1.6mm	25Ncm 	
IP VIT3-P	H 8mm NARROW Prosthetic Screw - Ø 1.6mm	25Ncm 	
IP VIT4L-P	H 20mm REGULAR Transfer Screw - Ø 2.0mm	32Ncm 	
IP VIT4-P	H 8mm REGULAR Prosthetic Screw - Ø 2.0mm	32Ncm 	



5° CONICAL CONNECTION IBK / BANP IM / BANP IC

VITR00	Vite Transfer Lunga - Long Spare Screw	25Ncm 	
VPF00	Vite Protesica Corta - Short Prosthetic Screw	32Ncm 	
VIPA 00AI	Vite Protesica T6 Prosthetic Screw (Avvitamento Angolato)	20Ncm 	
VIPA 00AITL	Vite Protesica Lunga T6 Long Prosthetic Screw (Avv. Ang.)	20Ncm 	
VPMU 00AI	Vite Protesica Toronto T6 Prosthetic Screw (Avv. Ang.)	15Ncm 	
VPMU 00AITL	Vite Protesica Lunga Toronto T6 Prosthetic Long Screw (Avv. Ang.)	15Ncm 	
EPVO	Vite Protesica OCTA Prosthetic Spare Screw	32Ncm 	
VIPA 00	Vite Protesica CONE Prosthetic Spare Screw	32Ncm 	

UNI-Q-MUA

EPMVL-Q	UNI-Q-MUA Transfer Screw - Ø 1.8mm	25Ncm 	
EPMV-Q	UNI-Q-MUA Prosthetic Screw - Ø 1.8mm	32Ncm 	
EPMVT6DS-Q	Prosthetic Screw T6 per Avvitamento Angolato - Ø 1.8mm	20Ncm 	

RICAMBI DI MOUNTERS IMPIANTI - IMPLANT MOUNTERS SPARE PARTS

EPM 40	H 12mm - Ø 4.7mm External Hexagon			
EPM 50	H 12mm - Ø 5.7mm External Hexagon			32Ncm 
IPM 35	H 12mm - Ø 4.5mm Internal Hexagon (IC30 - IC34)			
IPM 40	H 12mm - Ø 4.7mm Internal Hexagon (34 - 38 - 42)			
IPM 46	H 12mm - Ø 5.5mm Internal Hexagon (46 - 50)			
DM 1/2	Standard Hexagonal Driver			



INSTRUMENTS & DRILLS

IMPLANT TOOLS







⑤ standard surgical drills

FRESE HBM - Hard Bone Management

	07001604	Cortical Drill - Ø 1.6 mm - 11 mm
	04002104	Cortical Drill - Ø 2.1 mm - 11 mm
	FLS2313	Lance Drill - Ø 2.3 mm - 13 mm

FIS- Corticals

	FIS 30	Cortical Drill - Ø 3.0 mm
	FIS 35	Cortical Drill - Ø 3.5 mm
	FIS 40	Cortical Drill - Ø 4.0 mm
	FIS 45	Cortical Drill - Ø 4.5 mm
	FIS 50	Cortical Drill - Ø 5.0 mm

FCS - Cylindricals

	FCS 20	Cylindrical Drill - Ø 2.0 mm - Long 18 mm
	FCS 30	Cylindrical Drill - Ø 2.6 mm - Long 18 mm
	FCS 34	Cylindrical Drill - Ø 2.9 mm - Long 18 mm
	FCS 38	Cylindrical Drill - Ø 3.2 mm - Long 18 mm
	FCS 42	Cylindrical Drill - Ø 3.6 mm - Long 18 mm
	FCS 46	Cylindrical Drill - Ø 3.9 mm - Long 18 mm
	FCS 50	Cylindrical Drill - Ø 4.4 mm - Long 18 mm
	FCS 55	Cylindrical Drill - Ø 4.7 mm - Long 18 mm

Ⓢ standard surgical drills

FKS - Tapered

FKS 30	Tapered Drill - Ø 2.4 mm - Long 18 mm
FKS 34	Tapered Drill - Ø 2.9 mm - Long 18 mm
FKS 38	Tapered Drill - Ø 3.25 mm - Long 18 mm
FKS 42	Tapered Drill - Ø 3.5 mm - Long 18 mm
FKS 46	Tapered Drill - Ø 3.85 mm - Long 18 mm
FKS 50	Tapered Drill - Ø 4.35 mm - Long 18 mm
FKS 60	Tapered Drill - Ø 5.0 mm - 15 mm
FKS 80	Tapered Drill - Ø 7.0 mm - 15 mm



F- Nasal Pterygoid Long Drills

FCC 2025	N. Pterygoids Standard Drill - Ø 2.0mm
FKC 3425	N. Pterygoids Standard Drill - Ø 2.9mm
FKC 3825	N. Pterygoids Standard Drill - Ø 3.3mm
FKC 4225	N. Pterygoids Standard Drill - Ø 3.6mm



Mucotomi - Tissue Punches

ST M13	Manual Tissue Punche - Ø3.0mm
ST M14	Manual Tissue Punche - Ø4.1mm
ST M15	Manual Tissue Punche - Ø5.1mm
ST M23	Contrangle Tissue Punche - Ø3.0mm
ST M24	Contrangle Tissue Punche - Ø4.1mm
ST M25	Contrangle Tissue Punche - Ø5.1mm



© calibrated surgical drills

FCC 20 - Cylindricals



FCC 2007 Cylindrical Drill - Ø 2.0 mm - Long 7 mm



FCC 2008 Cylindrical Drill - Ø 2.0 mm - Long 8,5 mm



FCC 2010 Cylindrical Drill - Ø 2.0 mm - Long 10 mm



FCC 2011 Cylindrical Drill - Ø 2.0 mm - Long 11,5 mm



FCC 2013 Cylindrical Drill - Ø 2.0 mm - Long 13 mm

FKC 34 - Tapered



FKC 3407 Tapered Drill - Ø 2.9 mm - Long 7 mm



FKC 3408 Tapered Drill - Ø 2.9 mm - Long 8,5 mm



FKC 3410 Tapered Drill - Ø 2.9 mm - Long 10 mm



FKC 3411 Tapered Drill - Ø 2.9 mm - Long 11,5 mm



FKC 3413 Tapered Drill - Ø 2.9 mm - Long 13 mm

FKC 38 - Tapered



FKC 3807 Tapered Drill - Ø 3.2 mm - Long 7 mm



FKC 3808 Tapered Drill - Ø 3.2 mm - Long 8,5 mm



FKC 3810 Tapered Drill - Ø 3.2 mm - Long 10 mm



FKC 3811 Tapered Drill - Ø 3.2 mm - Long 11,5 mm



FKC 3813 Tapered Drill - Ø 3.2 mm - Long 13 mm

© calibrated surgical drills

FKC 42 - Tapered

FKC 4207 Tapered Drill - Ø 3.5 mm - Long 7 mm



FKC 4208 Tapered Drill - Ø 3.5 mm - Long 8,5 mm



FKC 4210 Tapered Drill - Ø 3.5 mm - Long 10 mm



FKC 4211 Tapered Drill - Ø 3.5 mm - Long 11,5 mm



FKC 4213 Tapered Drill - Ø 3.5 mm - Long 13 mm



FKC 46 - Tapered

FKC 4607 Tapered Drill - Ø 3.9 mm - Long 7 mm



FKC 4608 Tapered Drill - Ø 3.9 mm - Long 8,5 mm



FKC 4610 Tapered Drill - Ø 3.9 mm - Long 10 mm



FKC 4611 Tapered Drill - Ø 3.9 mm - Long 11,5 mm



FKC 4613 Tapered Drill - Ø 3.9 mm - Long 13 mm



FKC 50 - Tapered

FKC 5007 Tapered Drill - Ø 4.3 mm - Long 7 mm



FKC 5008 Tapered Drill - Ø 4.3 mm - Long 8,5 mm



FKC 5010 Tapered Drill - Ø 4.3 mm - Long 10 mm



FKC 5011 Tapered Drill - Ø 4.3 mm - Long 11,5 mm



FKC 5013 Tapered Drill - Ø 4.3 mm - Long 13 mm



special surgical drills

FC - Cylindricals



FC 2013B	Cylindrical Drill - Ø 2.0 mm - 13 mm
FC 2018B	Cylindrical Drill - Ø 2.0 mm - 18 mm
FC 2613B	Cylindrical Drill - Ø 2.6 mm - 13 mm
FC 2618B	Cylindrical Drill - Ø 2.6 mm - 18 mm
FC 3013B	Cylindrical Drill - Ø 3.0 mm - 13 mm
FC 3018B	Cylindrical Drill - Ø 3.0 mm - 18 mm
FC 3213B	Cylindrical Drill - Ø 3.2 mm - 13 mm
FC 3218B	Cylindrical Drill - Ø 3.2 mm - 18 mm
FC 3413B	Cylindrical Drill - Ø 3.4 mm - 13 mm
FC 3418B	Cylindrical Drill - Ø 3.4 mm - 18 mm
FC 3813B	Cylindrical Drill - Ø 3.8 mm - 13 mm
FC 3818B	Cylindrical Drill - Ø 3.8 mm - 18 mm
FC 4213B	Cylindrical Drill - Ø 4.2 mm - 13 mm
FC 4218B	Cylindrical Drill - Ø 4.2 mm - 18 mm

F - Special Drills



FLS2313	Lance Drill - Ø 2.3 mm - L13 mm
FLS2318	Lance Drill - Ø 2.3 mm - L18 mm
FBP	Bone Profiler - Ø 5.0 mm - Int/Ext Hex (Velocità Max di rotazione antioraria 80 rpm)
FT 3038	Trephine - Ø 3.0 mm / Ø 3.8 mm
FT 4048	Trephine - Ø 4.0 mm / Ø 4.8 mm
FT 5058	Trephine - Ø 5.0 mm / Ø 5.8 mm
FT 6068	Trephine - Ø 6.0 mm / Ø 6.8 mm
FBP-OT5	Bone Profiler OneTime - Ø 5.0 mm ●
FBP-OT6	Bone Profiler OneTime - Ø 6.0 mm ●
PF	Drill Extension - Prolunga per Frese

FG - Guided Nasal Pterygoid Long Drills

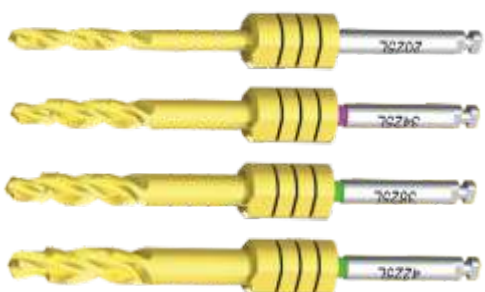

FGR 2025L	N. Pterygoids Guided Drill - Ø 2.0mm
FGR 3425L	N. Pterygoids Guided Drill - Ø 2.9mm
FGR 3825L	N. Pterygoids Guided Drill - Ø 3.3mm
FGR 4225L	N. Pterygoids Guided Drill - Ø 3.6mm

COMPUTER GUIDED SURGERY

GUIDED SURGERY TOOLS



computer guided surgery

MASCHERINA CHIRURGICA - Mascherina on demand multi-impianti

SURGICAL GUIDE - Multi-implants on demand surgical guide

- DS PAK** Progetto + Mascherina + Modello + Boccole
- DS PAK-M** Progetto + Mascherina + Boccole
- DS PAK-M1** Progetto + Mascherina + 1 Boccola
- DS PAK-M4** Progetto + Mascherina + 2/4 Boccole
- DS PAK-M8** Progetto + Mascherina + 5/8 Boccole

- DS PAK 1** Progetto + Mascherina + Modello + 1 Boccola
- DS PAK 4** Progetto + Mascherina + Modello + 2/4 Boccola
- DS PAK 8** Progetto + Mascherina + Modello + 5/8 Boccola

NB - Supporto tecnico sul posto per i primi 3 interventi
Kit Chirurgico in comodato d'uso per i primi 3 interventi

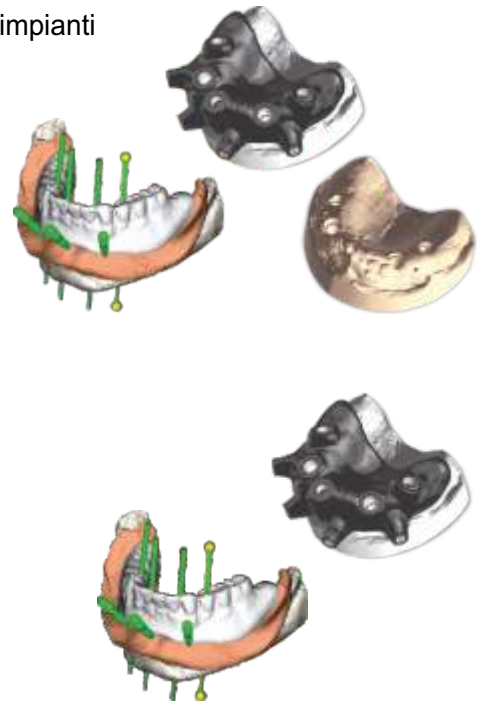

MODELLI - Modelli Stereolitografati

MODELS - Stereolithographed models

- DS MOD** Modello Master da Laboratorio da File STL per Analoghi
- DS MOD AS** Modello Anatomico Piccolo da Files DCM
- DS MOD AL** Modello Anatomico Grande da Files DCM



MASCHERINA CHIRURGICA SCOMPONIBILE

MODULAR SURGICAL GUIDE

- DS PAK SM** Progetto + Mascherina Scomponibile 3pz + 2 Modelli + Boccole

NB - Supporto tecnico sul posto per i primi 3 interventi
Kit Chirurgico in comodato d'uso per i primi 3 interventi

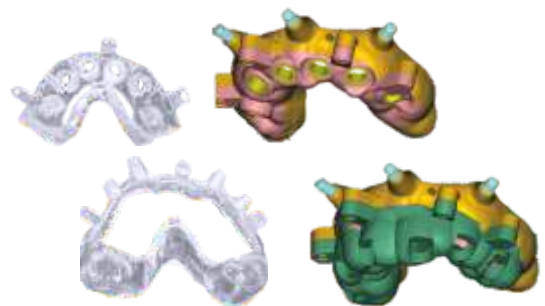

PROTESI PROVVISORIA IMMEDIATA - PMMA Stratificato Fresato e Armatura in Titanio Fresata

IMMEDIATE TEMPORARY PROSTHESIS - Drilled PMMA and Milled Titanium Framework

- DS PTD** Protesi Provvisoria Total Digital - PMMA + Armatura
- DS PD1** Protesi Provvisoria Digitale - PMMA 1 Elemento
- DS PD2/10** Protesi Provvisoria Digitale - PMMA da 2 a 10 Elementi



computer guided surgery



CORSI DI FORMAZIONE TEORICO/PRATICI SU PC

Il futuro è digitale e la chirurgia computer guidata cammina al fianco della rivoluzione cad-cam che sta trasformando il nostro lavoro imparare le basi, conoscerne le potenzialità, comprenderne i limiti per evitare errori e per migliorare il nostro quotidiano

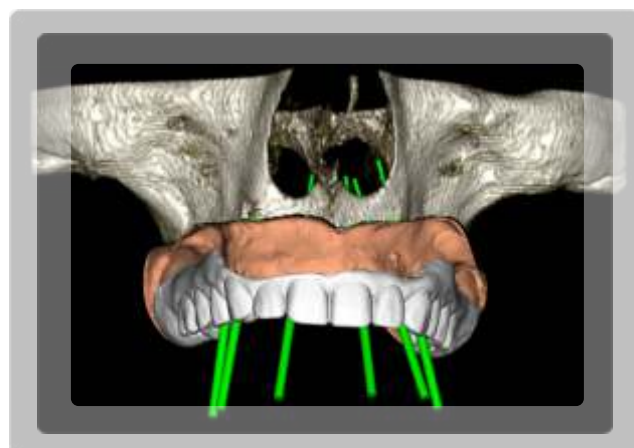
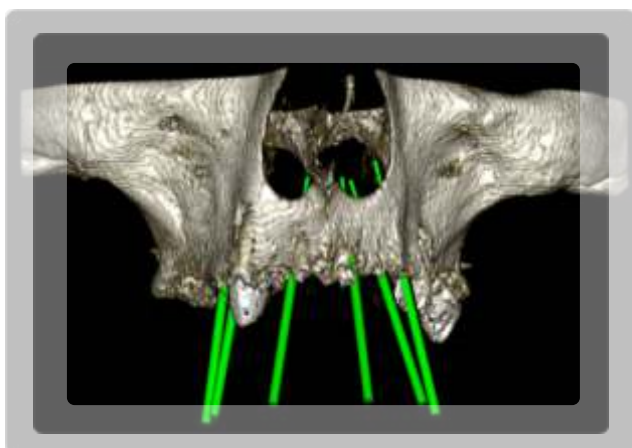



guided surgery drills



SMALL DRIVER
Ø 4.15



LARGE DRIVER
Ø 5.5

FG - Special drills



- FG P15** Pins Drill - Ø 1.5 mm
- FG B55 L** Bone Mill Drill - Ø 5.5 mm - Large
- FG B41 S** Bone Mill Drill - Ø 4.15 mm - Small

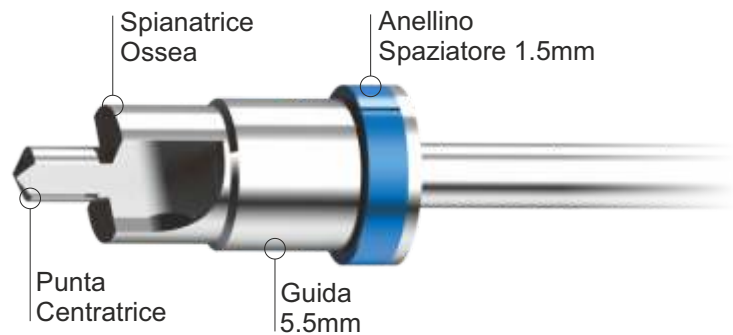

FG M - Mucotomes



- FG M41 S** Mucotome Drill - Ø 4.1 mm - Small
- FG M45 L** Mucotome Drill - Ø 4.5 mm - Large
- FG M55 L** Mucotome Drill - Ø 5.3 mm - Large

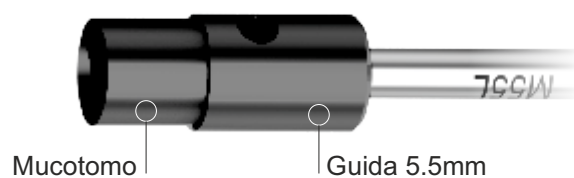

guided surgery drills



FG C - Cortical Drills

- FG C35 S** Cortical Drill - Ø 3.5 mm - Small
- FG C40 S** Cortical Drill - Ø 4.0 mm - Small

- FG C35 L** Cortical Drill - Ø 3.5 mm - Large
- FG C40 L** Cortical Drill - Ø 4.0 mm - Large
- FG C50 L** Cortical Drill - Ø 5.0 mm - Large



FG 20 S - First Drills Small Driver

- FGR 2008 S** First Drill - Ø 2.0 mm - Long 8,5 mm
- FGR 2010 S** First Drill - Ø 2.0 mm - Long 10 mm
- FGR 2011 S** First Drill - Ø 2.0 mm - Long 11,5 mm
- FGR 2013 S** First Drill - Ø 2.0 mm - Long 13 mm
- FGR 2015 S** First Drill - Ø 2.0 mm - Long 15 mm



FG 20 L - First Drills Large Driver

- FGR 2008 L** First Drill - Ø 2.0 mm - Long 8,5 mm
- FGR 2010 L** First Drill - Ø 2.0 mm - Long 10 mm
- FGR 2011 L** First Drill - Ø 2.0 mm - Long 11,5 mm
- FGR 2013 L** First Drill - Ø 2.0 mm - Long 13 mm
- FGR 2015 L** First Drill - Ø 2.0 mm - Long 15 mm





guided surgery drills

FG 34 L - 3.4 Implant Drills Small Driver



- FGR 3408 S** 3.4 Implant Drill - Ø 2.9 mm - Long 8,5 mm
- FGR 3410 S** 3.4 Implant Drill - Ø 2.9 mm - Long 10 mm
- FGR 3411 S** 3.4 Implant Drill - Ø 2.9 mm - Long 11,5 mm
- FGR 3413 S** 3.4 Implant Drill - Ø 2.9 mm - Long 13 mm
- FGR 3415 S** 3.4 Implant Drill - Ø 2.9 mm - Long 15 mm

FG 34 L - 3.4 Implant Drills Large Driver



- FGR 3408 L** 3.4 Implant Drill - Ø 2.9 mm - Long 8,5 mm
- FGR 3410 L** 3.4 Implant Drill - Ø 2.9 mm - Long 10 mm
- FGR 3411 L** 3.4 Implant Drill - Ø 2.9 mm - Long 11,5 mm
- FGR 3413 L** 3.4 Implant Drill - Ø 2.9 mm - Long 13 mm
- FGR 3415 L** 3.4 Implant Drill - Ø 2.9 mm - Long 15 mm

FG 38 S - 3.8 Implant Drills Small Driver



- FGR 3808 S** 3.8 Implant Drill - Ø 3.3 mm - Long 8,5 mm
- FGR 3810 S** 3.8 Implant Drill - Ø 3.3 mm - Long 10 mm
- FGR 3811 S** 3.8 Implant Drill - Ø 3.3 mm - Long 11,5 mm
- FGR 3813 S** 3.8 Implant Drill - Ø 3.3 mm - Long 13 mm
- FGR 3815 S** 3.8 Implant Drill - Ø 3.3 mm - Long 15 mm

FG 38 L - 3.8 Implant Drills Large Driver



- FGR 3808 L** 3.8 Implant Drill - Ø 3.3 mm - Long 8,5 mm
- FGR 3810 L** 3.8 Implant Drill - Ø 3.3 mm - Long 10 mm
- FGR 3811 L** 3.8 Implant Drill - Ø 3.3 mm - Long 11,5 mm
- FGR 3813 L** 3.8 Implant Drill - Ø 3.3 mm - Long 13 mm
- FGR 3815 L** 3.8 Implant Drill - Ø 3.3 mm - Long 15 mm

guided surgery drills

FG 42 S - 4.2 Implant Drills Small Driver

- FGR 4208 S** 4.2 Implant Drill - Ø 3.6 mm - Long 8,5 mm
- FGR 4210 S** 4.2 Implant Drill - Ø 3.6 mm - Long 10 mm
- FGR 4211 S** 4.2 Implant Drill - Ø 3.6 mm - Long 11,5 mm
- FGR 4213 S** 4.2 Implant Drill - Ø 3.6 mm - Long 13 mm
- FGR 4215 S** 4.2 Implant Drill - Ø 3.6 mm - Long 15 mm



FG 42 L - 4.2 Implant Drills Large Driver

- FGR 4208 L** 4.2 Implant Drill - Ø 3.6 mm - Long 8,5 mm
- FGR 4210 L** 4.2 Implant Drill - Ø 3.6 mm - Long 10 mm
- FGR 4211 L** 4.2 Implant Drill - Ø 3.6 mm - Long 11,5 mm
- FGR 4213 L** 4.2 Implant Drill - Ø 3.6 mm - Long 13 mm
- FGR 4215 L** 4.2 Implant Drill - Ø 3.6 mm - Long 15 mm



FG 46 L - 4.6 Implant Drills Large Driver

- FGR 4608 L** 4.6 Implant Drill - Ø 3.9 mm - Long 8,5 mm
- FGR 4610 L** 4.6 Implant Drill - Ø 3.9 mm - Long 10 mm
- FGR 4611 L** 4.6 Implant Drill - Ø 3.9 mm - Long 11,5 mm
- FGR 4613 L** 4.6 Implant Drill - Ø 3.9 mm - Long 13 mm
- FGR 4615 L** 4.6 Implant Drill - Ø 3.9 mm - Long 15 mm



FG 50 L - 5.0 Implant Drills Large Driver

- FGR 5008 L** 5.0 Implant Drill - Ø 4.3 mm - Long 8,5 mm
- FGR 5010 L** 5.0 Implant Drill - Ø 4.3 mm - Long 10 mm
- FGR 5011 L** 5.0 Implant Drill - Ø 4.3 mm - Long 11,5 mm
- FGR 5013 L** 5.0 Implant Drill - Ø 4.3 mm - Long 13 mm





guided surgery tools

Guided Mounters



IP4MG 4S

Mounter Guidata - Internal Hex ● Small Drive

IP4MG 4L

Mounter Guidata - Internal Hex ● Large Drive



SP3MG 3S

Mounter Guidata - External Hex ● Small Drive

SP4MG 4S

Mounter Guidata - External Hex ● Small Drive

SP4MG 4L

Mounter Guidata - External Hex ● Large Drive



IP3MG 3S-P

Mounter Guidata - Platinum CC ● Small Drive

IP3MG 3L-P

Mounter Guidata - Platinum CC ● Large Drive

IP4MG 4L-P

Mounter Guidata - Platinum CC ● Large Drive

IP4MG 4S

Mounter Guidata - Internal Hex ● Small Drive

IP4MG 4L

Mounter Guidata - Internal Hex ● Large Drive

Allineatori di Fase Esagonale Hexagonal Phase Aligners



Large Peek Sleeve



Small Peek Sleeve



Large Titanium Sleeve



Small Titanium Sleeve



guided surgery protocol

1 DATI DICOM

Cartella di file DCM - Soltanto files puri (non criptati e senza programma viewer), tagli non superiori a 0.5 mm, FOV adeguato al volume da diagnosticare, paziente fermo e comodo, testa dritta, distanziatore tra le arcate di 1.5 cm con dentatura fissa antagonista, energia consigliata 80/90 kVp con algoritmi HD low- scattering.



2 STL ANATOMICO

Edentulia Parziale - da scanner intraorale o impronta tradizionale

Edentulia Totalele - da impronta tradizionale, mucocompressiva, estesa il più possibile compreso tutto il palato



3 STL PROTESICO

Edentulia Parziale - modellato in 3D in laboratorio ed allineato all' STL Anatomico

Edentulia Totalele - dal duplicato della protesi congrua con markers radiologici esterni (5 posizioni) ben visibili, allineato al modello o con scansione completa interna ed esterna



4 CREAZIONE DEL CASO

Pianifichiamo in ambiente virtuale il caso chirurgico/protesico trasformando i vostri dati paziente in un caso unico, proponendovi più progetti visionabili sul vostro software condivisi in cloud e vi accompagniamo in ogni forma di apprendimento.

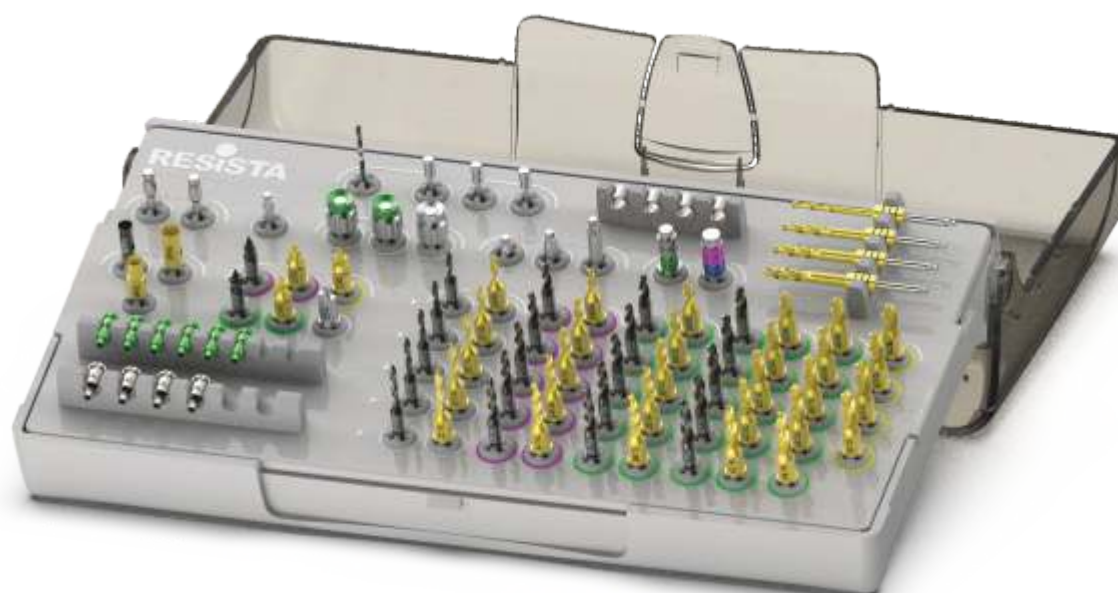
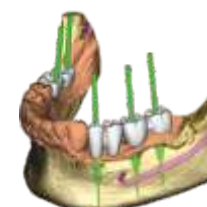

Guided Surgery REVO (Full Optional su Richiesta)

surgical kits



KIT 001
Monolinea



KIT 002
C-K-A Multilinea

KIT FCK
Calibrate K



KBS Kit Boccole Spaziatrici REVO



BPIF Base Svita Impianti



Kit Protesico
REPLICA



surgical kits

KIT 001MC	Kit Chirurgico Monolinea Cilindriche - BOX02 + Frese + Accessori
KIT 001MK	Kit Chirurgico Monolinea Coniche - BOX02 + Frese + Accessori
KIT 001PC	Kit Chirurgico Monolinea Platinum Cilindriche - BOX02 + Frese + Accessori
KIT 001PK	Kit Chirurgico Monolinea Platinum Coniche - BOX02 + Frese + Accessori
KIT 002	Kit Chirurgico Standard - BOX + Frese + Accessori
KIT 002P	Kit Chirurgico Platinum Standard - BOX + Frese + Accessori
KIT 004	Kit Chirurgico Mini Implant - BOX 03 + CRND + Frese + Accessori
KIT FCK	Kit Chirurgico Calibrate K - BOX FCK + Frese + Accessori
KIT 009	Kit Chirurgico UNI-Q-MUA 2.0 - BOX 02 + Frese + Accessori
KIT RPS01	Kit Protesico REPLICA - BOX RP01 + 5 Drivers Corti
KIT RPS02	Kit Protesico REPLICA - BOX RP01 + 5 Drivers Corti + Cricchetto Dinamom.
KIT RPL01	Kit Protesico REPLICA - BOX RP01 + 5 Drivers Lunghi
KIT RPL02	Kit Protesico REPLICA - BOX RP01 + 5 Drivers Lunghi + Cricchetto Dinamom.
BOX	Box Chirurgico Implantologia Large - Solo contenitore
BOX 02	Box Chirurgico Implantologia Monolinea Medium - Solo contenitore
BOX RP01	Box Protesico REPLICA - Solo contenitore
KIT 005	Kit Chirurgico Espansori - BOX 03 + 4 Espansori + Accessori
KIT 006	Kit Chirurgico Espansori Base - BOX 03 + 4 Espansori
KIT PINK	Kit Misuratori di Parallelismo - BOX P + 10 PIN
KIT 007	Kit Rimozione Impianti EXT - BOX 03 + 2 Estrattori + Accessori
KIT RI	Kit Rimozione Impianti REPLICA - BOX + 3 Estrattori + 4 Viti + Accessori
KIT RV	Kit Rimozione Viti Fratturate REPLICA - BOX + 2 Frese + Guida + Accessori
KIT 012	Kit REVO Chirurgia Guidata - BOX + 59 Frese + Accessori
KIT 012L	Kit REVO Chirurgia Guidata solo Frese Larghe - BOX + 36 Frese + Accessori
BOX GR	Box REVOLUTION Chirurgia Guidata - Solo contenitore
KIT KN	Kit K Narrow - Box + Frese + Accessori
BPIF	Base Svita Impianti - Base in Titanio per la Rimozione del Mount
KBS	Kit Boccole Spaziatrici - 8 Boccole 2 colori per tipo + Box Inox
RBS	Ricambi Boccole Spaziatrici - 8 Boccole 2 colori per tipo



OVERDENTURE & PROSTHETICS

ATTACHMENTS





Kit OT Equator Esagono Interno - Pilastro + Contenitore + Cappette

Kit OT Equator Internal Hexagon - Abutment + Box + Caps

- | | | |
|---------------|----------------------------------|---|
| IP3EQ2 | Kit OT Equator h2 mm Narrow Ø3.5 | ● |
| IP3EQ3 | Kit OT Equator h3 mm Narrow Ø3.5 | ● |
| IP3EQ4 | Kit OT Equator h4 mm Narrow Ø3.5 | ● |
| IP3EQ5 | Kit OT Equator h5 mm Narrow Ø3.5 | ● |
| IP3EQ6 | Kit OT Equator h6 mm Narrow Ø3.5 | ● |
| IP4EQ1 | Kit OT Equator h1 mm Ø4.0 CPS | ● |
| IP4EQ2 | Kit OT Equator h2 mm Ø4.0 CPS | ● |
| IP4EQ3 | Kit OT Equator h3 mm Ø4.0 CPS | ● |
| IP4EQ4 | Kit OT Equator h4 mm Ø4.0 CPS | ● |
| IP4EQ5 | Kit OT Equator h5 mm Ø4.0 CPS | ● |
| IP4EQ6 | Kit OT Equator h6 mm Ø4.0 CPS | ● |



Kit OT Equator 5° C.C. BANP - Pilastro + Contenitore + Cappette

Kit OT Equator 5° C.C. BANP - Abutment + Box + Caps

- | | | |
|---------------|-----------------------------------|---|
| BPE Q1 | Kit OT Equator h1 mm 5° BANP Ø4.0 | ● |
| BPE Q2 | Kit OT Equator h2 mm 5° BANP Ø4.0 | ● |
| BPE Q3 | Kit OT Equator h3 mm 5° BANP Ø4.0 | ● |
| BPE Q4 | Kit OT Equator h4 mm 5° BANP Ø4.0 | ● |
| BPE Q5 | Kit OT Equator h5 mm 5° BANP Ø4.0 | ● |



Kit OT Equator 12° C.C. Platinum - Pilastro + Contenitore + Cappette

Kit OT Equator 12° C.C. Platinum - Abutment + Box + Caps

- | | | |
|-----------------|--------------------------------------|---|
| IP3EQ1-P | Kit OT Equator h1 mm Conical C. - NP | ● |
| IP3EQ2-P | Kit OT Equator h2 mm Conical C. - NP | ● |
| IP3EQ3-P | Kit OT Equator h3 mm Conical C. - NP | ● |
| IP3EQ4-P | Kit OT Equator h4 mm Conical C. - NP | ● |
| IP3EQ5-P | Kit OT Equator h5 mm Conical C. - NP | ● |
| IP3EQ6-P | Kit OT Equator h6 mm Conical C. - NP | ● |
| IP4EQ1-P | Kit OT Equator h1 mm Conical C. - RP | ● |
| IP4EQ2-P | Kit OT Equator h2 mm Conical C. - RP | ● |
| IP4EQ3-P | Kit OT Equator h3 mm Conical C. - RP | ● |
| IP4EQ4-P | Kit OT Equator h4 mm Conical C. - RP | ● |
| IP4EQ5-P | Kit OT Equator h5 mm Conical C. - RP | ● |
| IP4EQ6-P | Kit OT Equator h6 mm Conical C. - RP | ● |

overdenture

Kit OT Equator K Narrow 29 - Pilastro + Contenitore + Cappette

Kit OT Equator K Narrow 29 - Abutment + Box + Caps

- EP2EQ1** Kit OT Equator h1 mm K Narrow Ø3.0 ●
- EP2EQ2** Kit OT Equator h2 mm K Narrow Ø3.0 ●
- EP2EQ3** Kit OT Equator h3 mm K Narrow Ø3.0 ●
- EP2EQ4** Kit OT Equator h4 mm K Narrow Ø3.0 ●
- EP2EQ5** Kit OT Equator h5 mm K Narrow Ø3.0 ●



RHEIN83

Kit OT Equator Esagono Esterno - Pilastro + Contenitore + Cappette

Kit OT Equator External Hexagon - Abutment + Box + Caps

- EP3EQ2** Kit OT Equator h2 mm Ø3.3 ●
- EP3EQ3** Kit OT Equator h3 mm Ø3.3 ●
- EP3EQ4** Kit OT Equator h4 mm Ø3.3 ●
- EP3EQ5** Kit OT Equator h5 mm Ø3.3 ●
- EP3EQ6** Kit OT Equator h6 mm Ø3.3 ●

- EP4EQ2** Kit OT Equator h2 mm Ø4.1 ●●
- EP4EQ3** Kit OT Equator h3 mm Ø4.1 ●●
- EP4EQ4** Kit OT Equator h4 mm Ø4.1 ●●
- EP4EQ5** Kit OT Equator h5 mm Ø4.1 ●●
- EP4EQ6** Kit OT Equator h6 mm Ø4.1 ●●

- EP5EQ2** Kit OT Equator h2 mm Ø5.0 ●●●
- EP5EQ3** Kit OT Equator h3 mm Ø5.0 ●●●
- EP5EQ4** Kit OT Equator h4 mm Ø5.0 ●●●
- EP5EQ5** Kit OT Equator h5 mm Ø5.0 ●●●
- EP5EQ6** Kit OT Equator h6 mm Ø5.0 ●●●



RHEIN83



overdenture

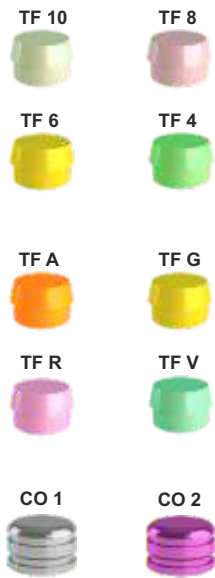

Femmine per Overdenture Normo - Ritenzioni Rhein Normo Overdenture Caps - Rhein Caps

TF 10	Teflon Bianca 1300 gr.
TF 08	Teflon Rosa 800 gr.
TF 06	Teflon Gialla 600 gr.
TF 04	Teflon Verde 400 gr.
TF A	Sottodimensionata - Teflon Arancione 350 gr.
TF G	Sottodimensionata - Teflon Gialla 500 gr.
TF R	Sottodimensionata - Teflon Rosa 900 gr.
TF V	Sottodimensionata - Teflon Verde 1300 gr.
CO 01	Metal Box - Stainless Steel
CO 02	Metal Box - Titanium



Femmine per Overdenture Micro - Ritenzioni Rhein Micro Overdenture Caps - Rhein Caps

TFM 10	Teflon Bianca 1100 gr.
TFM 08	Teflon Rosa 800 gr.
TFM 06	Teflon Gialla 450 gr.
TFM 04	Teflon Verde 200 gr.
TFM A	Sottodimensionata - Teflon Arancione 200 gr.
TFM V	Sottodimensionata - Teflon Verde 1100 gr.
COM 01	Metal Box - Stainless Steel
COM 02	Metal Box - Titanium



Femmine per Overdenture Equator - Ritenzioni Rhein Equator Overdenture Caps - Rhein Caps

TF Q1	Teflon Viola Forte
TF Q2	Teflon Bianco Normale
TF Q3	Teflon Rosa Morbida
TF Q4	Teflon Giallo Extra
TF Q5	Teflon Nero da Laboratorio
SBOX EQ	Smart Box - Autoparallellizzante Cont. + 5 Teflon
COQ 01	Metal Box - Stainless Steel
COQ 02	Metal Box - Titanium

overdenture

- AN D** Anelli Direzionali 0° - 7° - 14° - Conf 6pz.
- F20 SN** Sfera Normo Filettata - Passo Filetto M2.0
F18 SN Sfera Normo Filettata - Passo Filetto M1.8
F16 SN Sfera Normo Filettata - Passo Filetto M1.6
- F20 SM** Sfera Micro Filettata - Passo Filetto M2.0
F18 SM Sfera Micro Filettata - Passo Filetto M1.8
F16 SM Sfera Micro Filettata - Passo Filetto M1.6
- SGU SN** Spaziatore Sfera Normo per Guaina Filettata
SGU SM Spaziatore Sfera Micro per Guaina Filettata
- GU 16** Guaina Filettata da Incollaggio - Passo Filetto M1.6



- SC N** Sfera Calcinabile Normo Verde - 4pz.
SC M Sfera Calcinabile Micro Rossa - 4pz.
- DPI** Dischetto Protettivo per Incollaggio Trasparente - 10pz.
- SC 25** Sfera Cava da Incollaggio Normo - Per sfere usurate - 2pz.
SC 18 Sfera Cava da Incollaggio Micro - Per sfere usurate - 2pz.
- BA 01** Barra tipo Dolder Calcinabile
- BA 02** Ritenzione in Teflon **Rosa** per Barra
BA 03 Ritenzione in Teflon **Gialla** per Barra



- BCA N** Barra Calcinabile Angolare **Normo** Verde - 2pz.
BCD N Barra Calcinabile Diritta **Normo** Verde - 2pz.
- BCA M** Barra Calcinabile Angolare **Micro** Rossa - 2pz.
BCD M Barra Calcinabile Diritta **Micro** Rossa - 2pz.
- F20 EQ** Equator Filettato - Passo Filetto M2.0
F16 EQ Equator Filettato - Passo Filetto M1.6
- SGU EQ** Equator Spaziatore per Guaina Filettata
- AL EQ** Analogo per Laboratorio Equator





Kit LOCATOR® Esagono Interno - Pilastro + Contenitore + Caps

Kit LOCATOR® Internal Hexagon - Abutment + Box + Caps

- IP4LC1** Kit LOCATOR h1 mm - Ø4.0 CPS ●
- IP4LC2** Kit LOCATOR h2 mm - Ø4.0 CPS ●
- IP4LC3** Kit LOCATOR h3 mm - Ø4.0 CPS ●
- IP4LC4** Kit LOCATOR h4 mm - Ø4.0 CPS ●
- IP4LC5** Kit LOCATOR h5 mm - Ø4.0 CPS ●
- IP4LC6** Kit LOCATOR h6 mm - Ø4.0 CPS ●



Kit LOCATOR® Esagono Esterno - Pilastro + Contenitore + Caps

Kit LOCATOR® External Hexagon - Abutment + Box + Caps

- EP4LC1** Kit LOCATOR h1 mm - Ø4.1 ●●
- EP4LC2** Kit LOCATOR h2 mm - Ø4.1 ●●
- EP4LC3** Kit LOCATOR h3 mm - Ø4.1 ●●
- EP4LC4** Kit LOCATOR h4 mm - Ø4.1 ●●
- EP4LC5** Kit LOCATOR h5 mm - Ø4.1 ●●



Kit LOCATOR® Connessione Conica - Pilastro + Contenitore + Caps

Kit LOCATOR® Conical Connection - Abutment + Box + Caps

- IP3LC1-P** Kit LOCATOR h1.5 mm - Conical C. - NP ●
- IP3LC2-P** Kit LOCATOR h2.5 mm - Conical C. - NP ●
- IP3LC5-P** Kit LOCATOR h5.0 mm - Conical C. - NP ●
- IP4LC1-P** Kit LOCATOR h1.5 mm - Conical C. - RP ●
- IP4LC2-P** Kit LOCATOR h2.5 mm - Conical C. - RP ●
- IP4LC5-P** Kit LOCATOR h5.0 mm - Conical C. - RP ●

overdenture

Kit LOCATOR® Connessione Conica 5° - Pilastro + Contenitore + Cappette

Kit LOCATOR® 5° Conical Connection - Abutment + Box + Caps

- BPLC1** Kit LOC Abutment H1 mm - Ø4.0 ●
- BPLC2** Kit LOC Abutment H2 mm - Ø4.0 ●
- BPLC3** Kit LOC Abutment H3 mm - Ø4.0 ●
- BPLC4** Kit LOC Abutment H4 mm - Ø4.0 ●
- BPLC5** Kit LOC Abutment H5 mm - Ø4.0 ●



LOCATOR®

Accessori e Ricambi LOCATOR®

LOCATOR® Accessories and Spare Parts

- W2-TSLC** Transfer Ti + Cappetta Nera (per laboratorio)
- W2-COLC1** Contenitore Ti + Cappetta Nera (per laboratorio)
- W2-NBOXLC** Kit Cappette + Contenitore Ti
- W2-TFLC50** Cappetta Ritentiva Trasparente - 2268 g 4 pz.
- W2-TFLC30** Cappetta Ritentiva Rosa - 1361 g 4 pz.
- W2-TFLC15** Cappetta Ritentiva Blu - 680 g 4 pz.
- W2-ALLC** Analogo in Titanio
- W2-TFLCD40** Cappetta Ritentiva Verde - 1814 g 4 pz.
- W2-TFLCD20** Cappetta ritentiva Arancione - 907 g 4 pz.
- W2-TFLCD15** Cappetta ritentiva Rossa - 680 g 4 pz.
- W2-DMLC** Avvitatore manuale Cricchetto (Straumann®)
- W2-DCLC** Avvitatore da Contrangolo
- W2-IELC** Inseritore / Estrattore Cappette

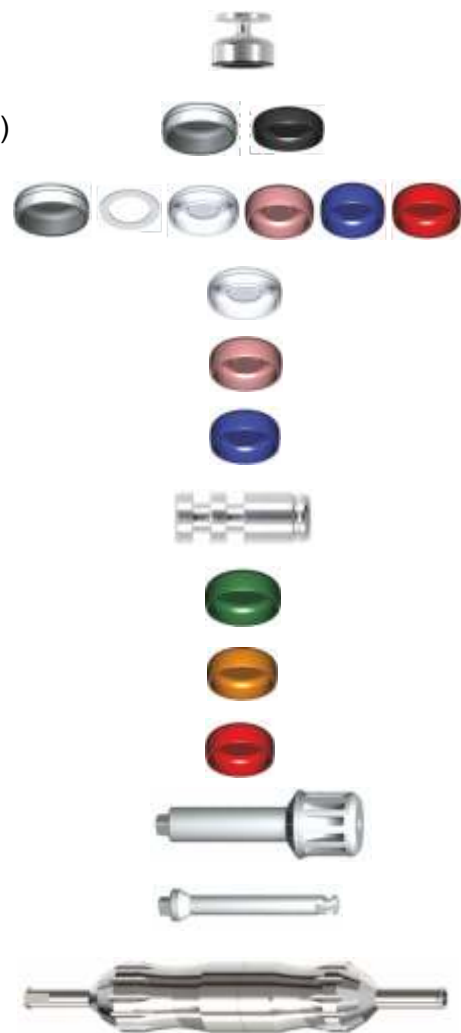

LOCATOR®











INSTRUMENTS & TOOLS

SURGICAL ACCESSORIES











instruments & tools





Cacciaviti Manuali - Manual Screw Drivers

	DM 01	Hexagonal 1.27 - Short - 12mm
	DM 02	Hexagonal 1.27 - Medium - 17mm
	DM 03	Hexagonal 1.27 - Long - 27mm
	DMX 01	Torx - Short - 15mm
	DMX 02	Torx - Long - 20mm
	DMRP120S	Hexagonal 1.20 - Short
	DMRP120L	Hexagonal 1.20 - Long
	DM T6DS	T6 Angled Torx Driver - 15mm
	DMEQ	Equator Squared - Short - 15mm

Cacciaviti da Contrangolo - Contra-angle Screw Drivers

	DC 01	Hexagonal 1.27 - Short - 15mm
	DC 02	Hexagonal 1.27 - Medium - 20mm
	DC 03	Hexagonal 1.27 - Long - 30mm
	ACDRCA	Hexagonal 1.20
	DC T6DS	T6 Angled Torx Driver - 20mm
	DCEQ	Equator Squared - Medium - 20mm
	DCX 01	Torx - Short - 15mm
	DCX 02	Torx - Long - 20mm

Cacciaviti Pilastrì Transgengivali - OCTA Transgingival Abutment Drivers

	DCM	Straight Toronto MUA Contra-angle Driver
	MU10AM	Straight Toronto MUA Manual Driver
	DCOC01	Octagonal One Abutment Driver - Short
	DCOC02	Octagonal One Abutment Driver - Long
	ACOC01	Octagonal One Abutment Driver - Short
	ACOC02	Octagonal One Abutment Driver - Long

instruments & tools

Cacciaviti da Cricchetto - Torque Controller Drivers

- DCD 01** Hexagonal 1.27 - Short - 15mm
- DCD 02** Hexagonal 1.27 - Medium - 20mm
- DCD 03** Hexagonal 1.27 - Long - 30mm
- DCDX 01** Torx - Short - 15mm
- DCDX 02** Torx - Long - 20mm
- DCDM** Hexagonal - Monconi Toronto Diritti

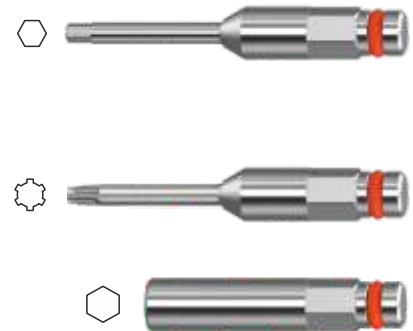

Avvitatori Manuali - Finger Manual Device

- DGM** Digitale Manuale - Manual Implant Driver
- DKX** Avvitatore Manuale per RA - RA Manual Driver
- UNADCR
CAES35** Adattatore CRD2 da Es. 3,5 a RA - CRD2 Adapter from Hex 3,5 to RA

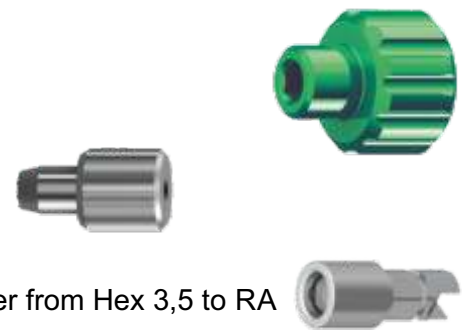

[NB Controllare compatibilità vecchio e nuovo ed in alternativa catalogo REPLICA](#)

Avvitatori per Mini Impianti - Mini Implants Drivers

- PCM** Cricchetto - Ratchet **Mini Implant** Driver
- ACM** Contrangolo - Contrangle **Mini Implant** Driver

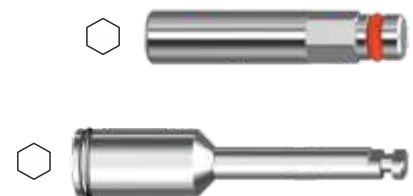

Avvitatori Impianto 5° Oneseal BANP - 5° Oneseal BANP Implant Drivers

- ACMOCA** Contra-angle Implant Driver - Short
- ACMOCL** Contra-angle Implant Driver - Long
- ACMOMC** Manual Implant Driver - Short
- ACMOML** Manual Implant Driver - Long

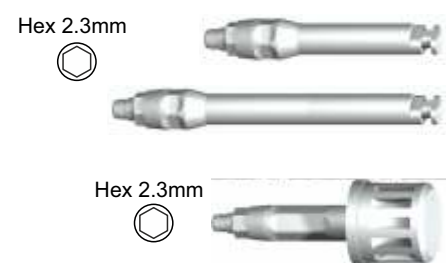

instruments & tools



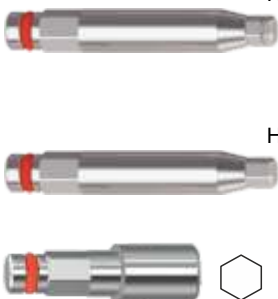



Prolunghe da Cricchetto IK/IC/IA/EC - IK/IC/IA/EC Ratchet Implant Drivers

	Hex 2.42mm	PC 01R	Short - Hexagonal Implant Driver	I E
		PC 02R	Medium - Hexagonal Implant Driver	
		PC 03R	Long - Hexagonal Implant Driver	
	Hex 2.42mm	PC 02	Medium - Hexagonal Implant Driver No O-Ring	
		PC 03	Long - Hexagonal Implant Driver No O-Ring	
		PR PC	Prolunga per PC - PC Extension	





Prolunghe da Cricchetto IBK BANP - IBK BANP Ratchet Implant Drivers

	Hex 2.3mm	ACMOMC	Short - Hexagonal Manual Implant Driver	B
		ACMOML	Long - Hexagonal Manual Implant Driver	

Prolunghe da Cricchetto ES - ES Ratchet Implant Drivers

		PC ES1	Medium - Star Grip Driver for ES 40	ES
		PC ES2	Long - Star Grip Driver for ES 40	
		PC ES3S	Short - Star Grip Driver for ES 33	
		PC ES3L	Long - Star Grip Driver for ES 33	
		PC ES5S	Short - Star Grip Driver for ES 50	
		PC ES5L	Long - Star Grip Driver for ES 50	

Prolunghe da Cricchetto Platinum - Platinum Ratchet Implant Drivers

		PC P3S	Short - Conical Grip Driver Platinum	P
		PC P3M	Medium - Conical Grip Driver Platinum	
		PC P3L	Long - Conical Grip Driver Platinum	
		PC P4S	Short - Conical Grip Driver Platinum	
		PC P4M	Medium - Conical Grip Driver Platinum	
		PC P4L	Long - Conical Grip Driver Platinum	

instruments & tools

Avvitatori Contrangolo IK/IC/IA/EC - IK/IC/IA/EC Contra-angle Implant Drivers

- AC 01** Short - Contra-angle Implant Driver
- AC 02** Medium - Contra-angle Implant Driver

Hex 2.42mm



I E

Avvitatori Contrangolo IBK BANP - IBK BANP Contra-angle Implant Drivers

- ACMOCA** Short - Contra-angle Implant Driver
- ACMOCL** Long - Contra-angle Implant Driver

Hex 2.3mm



B

Avvitatori Contrangolo ES - ES Contra-angle Implant Drivers

- AC ES1** Short - Star Grip Driver for **ES 40**
- AC ES2** Medium - Star Grip Driver for **ES 40**
- AC ES301** Short - Star Grip Driver for **ES 33**
- AC ES302** Medium - Star Grip Driver for **ES 33**
- AC ES501** Short - Star Grip Driver for **ES 50**
- AC ES502** Medium - Star Grip Driver for **ES 50**



ES

Avvitatori da Contrangolo Platinum - Platinum Contra-angle Implant Drivers

- AC P3S** Short - Contra-angle Implant Driver **Platinum**
- AC P3M** Medium - Contra-angle Implant Driver **Platinum**
- AC P3L** Long - Contra-angle Implant Driver **Platinum**
- AC P4S** Short - Contra-angle Implant Driver **Platinum**
- AC P4M** Medium - Contra-angle Implant Driver **Platinum**
- AC P4L** Long - Contra-angle Implant Driver **Platinum**



P

instruments & tools



Accessori per Applicazione Manuale

Accessories for Manual Application

CD LAB Chiave Digitale da Laboratorio Es. 3,5

ALI Aiuto da Laboratorio Esagono Interno

ALE Aiuto da Laboratorio Esagono Esterno

**UNADCR
CAES35**



Adattatore da Es. 3,5 a RA

ALI



ALE



Supporto da Laboratorio per la lavorazione dei Monconi

0°



17°



32°



Perni di Parallelismo - Titanio Gr. 5

Paralleling Pins - Titanium Gr. 5

PIN Double diameter - S 1.8mm / L 3mm - 0°

PIN17 Double diameter - S 1.8mm / L 3mm - 17°

PIN32 Double diameter - S 1.8mm / L 3mm - 32°

PIN K Kit Misuratori di Parallelismo Calibrati
(10 PIN + BOX)



A 1.3
B 2.1
C 2.4



A 1.6
B 2.8
C 3.1



A 1.9
B 3.5
C 3.8



A 2.4
B 4.3
C 4.6

Osseo Espansori e Compattatori - Titanio Gr. 5

Bone Expanders and Compactors - Titanium Gr. 5

EXP 4 Progressive diameters

KIT 005 Expander Surgical Kit

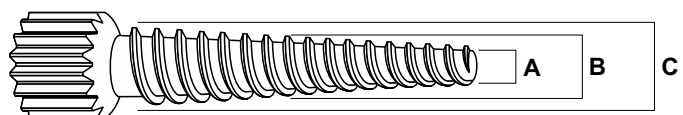

instruments & tools



CRND Cricchetto non Dinamometrico - No Torque Control Ratchet

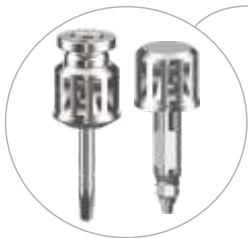

ACCRFI Cricchetto non Dinamometrico - No Torque Control Ratchet

CRD2-G



CRD2 Cricchetto Dinamometrico 10/70 Ncm - Torque Control

CRD2-G Ghiera Cricchetto CRD2 con Attacco PC - CRD2 Ratchet Wheel with PC Connection

UNADES35CR



CRDP2 Cricchetto Dinamometrico Protesico 10/70 Ncm - Torque Control

UNADES35CR Ghiera Cricchetto CRDP2 attacco PC - CRDP2 Ratchet Wheel PC Connection



CDL Avvitatore Diritto Manuale - Long Manual Driver

ST PRO SL1 Sonda Compattatore - Sinus Lift System



SOMB Sonda Chirurgica in Titanio
Titanium Surgical Probe

mini sinus lift kit

Frese Taglienti 120°



PRO Sinus Lift - Mini Rialzo del Seno per via Crestale

PRO Sinus Lift - Mini Sinus Lift with Crestal Approach

PRO SL Kit Kit Completo Box + Frese + Stop + Accessori

- FC 20** Fresa ● Tagliente 120° - Ø 2.0
- FC 2026** Fresa ● Tagliente 120° - Ø 2.0/2.6
- FC 2531** Fresa ● Tagliente 120° - Ø 2.5/3.1
- FC 31P** Fresa ● Atraumatica 180° - Ø 3.1
- FC 31PTX** Fresa ● Atraumatica TaglioX 180° - Ø 3.1
- FC 31R** Fresa ● Raggiata Atraumatica - Ø 3.1
- FC 3136R** Fresa ● Raggiata Atraumatica - Ø 3.1/3.6

KIT ST 6 Titanium Drill Stoppers
(6.0/7.0/8.5/10/11.5/13)

STP KIT 11 Titanium Drill Stoppers
(1.0/2.0/3.0/4.0/5.0/6.0/7.0/8.5/10/11.5/13)

ST Titanium Drill Stopper 1 pz. (Es. ST1, ST2, ST3)



Frese Atraumatiche (Max 100 rpm)



Frese Raggiate (Max 80 rpm)



nasal and pterygoids implants

TAPERED SHAPE
IK 42

NASAL
NP
PTERYGOIDS

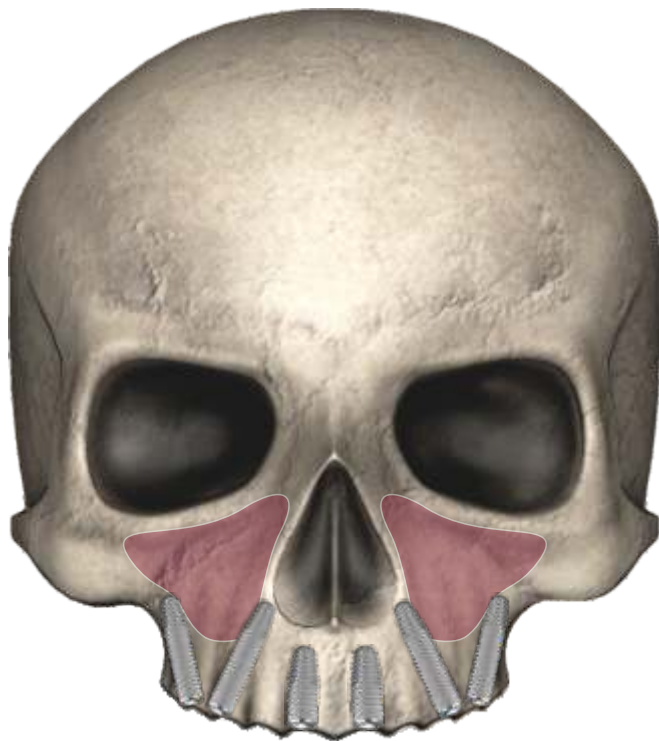

0.5 mm
Machined

Tapered 2°

Screw Pitch
0.8 mm

Tapered
6 mm



Codici Articolo disponibili a pagina 29 - Item Code available on page 29

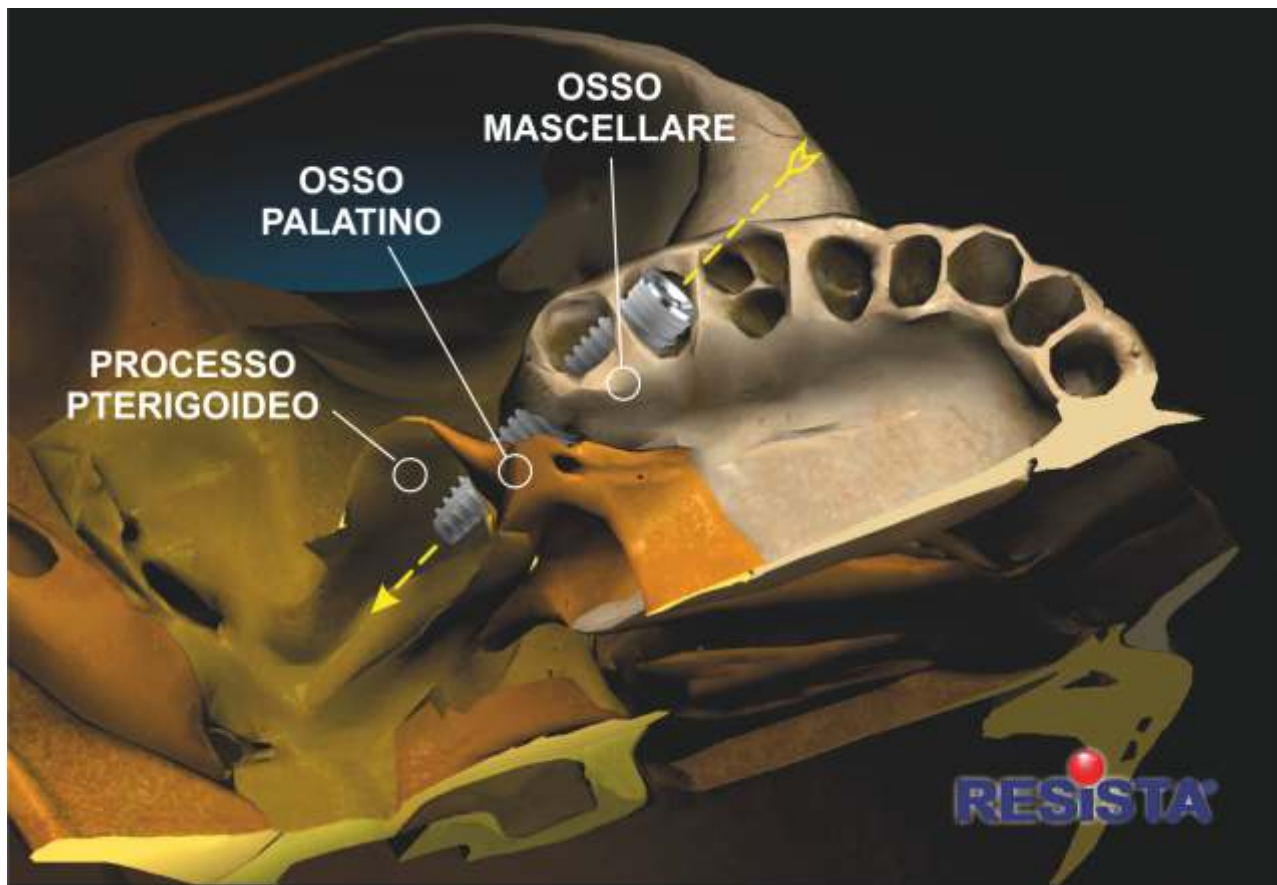

RESISTA

instruments and surgery tools

IMPIANTI FRATTURATI

UNIVERSAL IMPLANT EXTRACTOR

**IMPIANTO
FRATTURATO**

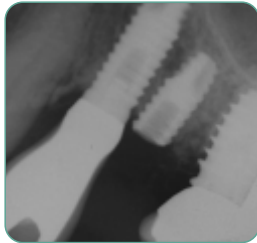

**IMPIANTO
SOSTITUITO**

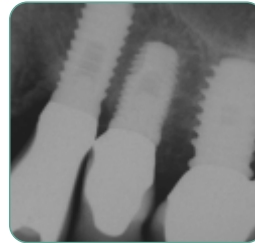

**RIMOZIONE IMPIANTO IN
AVVITAMENTO ANTIORARIO**



**SOSTITUZIONE IMMEDIATA
CON NUOVO IMPIANTO**



RIVESTIMENTO IN DLC
Durezza e Minore Attirito

CONICITÀ PROGRESSIVA
Incrementale

FILETTO 3 PRINCIPI
120Ncm

ACCIAIO EXTRADURO
68 Rockwell



EXT Implant Extractor - 1 pcs.

KIT 007 Implant Extractor Kit - 2 Extractors + 1 Box + CRND

Siringhe per Anestesia - Inox

Anesthesia Syringes - Stainless Steel



PERIPRESS



22 PERIPRESS - Siringa Inox 1.8cc - Set 2 Portafiala

32 PERIPRESS - Siringa Standard 1.8cc - Set 2 Portafiala



Ing. C. A. Issoglio & C. S.r.l.

Via F.lli Di Dio, 68 - 28887 Omegna (VB) - ITALIA

Tel. +39.0323.828.004 - Fax +39.0323.828.914

www.resista.it - info@resista.it