

BANP

2024

company profile



RESISTA®

Marchio di proprietà della **Ing. Carlo Alberto ISSOGLIO & C. S.r.l.** identifica l'intera gamma di prodotti concepiti dall'azienda per soddisfare le esigenze di odontoiatri ed odontotecnici.

since 1946

RESISTA è sinonimo di garanzia, equilibrio e continuità, noto in tutto il mondo.



RESISTA, trademark owned by Ing. Carlo Alberto Issoglio & C. S.r.l. , identifies the full range of products designed by the company to meet the needs of dentists and dental technicians.

RESISTA is known all over the world since 1946, and synonymous of guarantee, balance and continuity.

company profile

L'azienda dispone di un complesso produttivo per la realizzazione di dispositivi medici, tra i più moderni del settore, situato ad Omegna, una bellissima cittadina che si affaccia sul Lago d'Orta.

Con impegno, vanto ed orgoglio, il personale tecnico e scientifico del reparto Ricerca & Sviluppo è quotidianamente dedito a promuovere l'innovazione ed il miglioramento dei nostri prodotti e processi.



Negli anni, il marchio **RESISTA** è diventato anche sinonimo di risposta rapida e qualitativa ai cambiamenti del mercato e alle esigenze dell'odontoiatria moderna.

Qualità, Prezzo e Servizio riassumono in tre semplici parole la percezione quotidiana degli utilizzatori dei prodotti marchiati **RESISTA**.



The company has one of the most ip-to-date manufacturing site for the medical devices, located in Omegna, a beautiful town on Orta Lake, Italy.

With commitment, merit and pride, the technical and scientific staff of the R&D department is daily involved to promote innovation and the improvement of our products and processes.

Over the years, the **RESISTA** brand has also become synonymous of fast and qualitative response to market changes and the needs of modern dentistry.

Quality, Price and Service summarize in three simple words the daily perception of the users of **RESISTA** branded products.

the choice

RICERCA & SVILUPPO - Il programma R&D di Resista Group nasce dalle indicazioni provenienti dal mondo clinico unite alla nostra esperienza maturata nel campo dei dispositivi medici impiantabili.

Con l'utilizzo di programmi di modellazione 3D e sofisticati sistemi computerizzati simuliamo le geometrie finali ed il design, sviluppando le fasi di prototipizzazione rapida dei progetti.



INNOVAZIONI - Resista Group è strutturata per soddisfare tutte le esigenze del metal-implant con una avanzata tecnologia di concezione, prototipizzazione ed ingegnerizzazione finale del prodotto per arrivare a soluzioni innovative.

La validazione viene eseguita in collaborazione con Istituti di Ricerca accreditati in conformità ai requisiti degli Standard Internazionali.

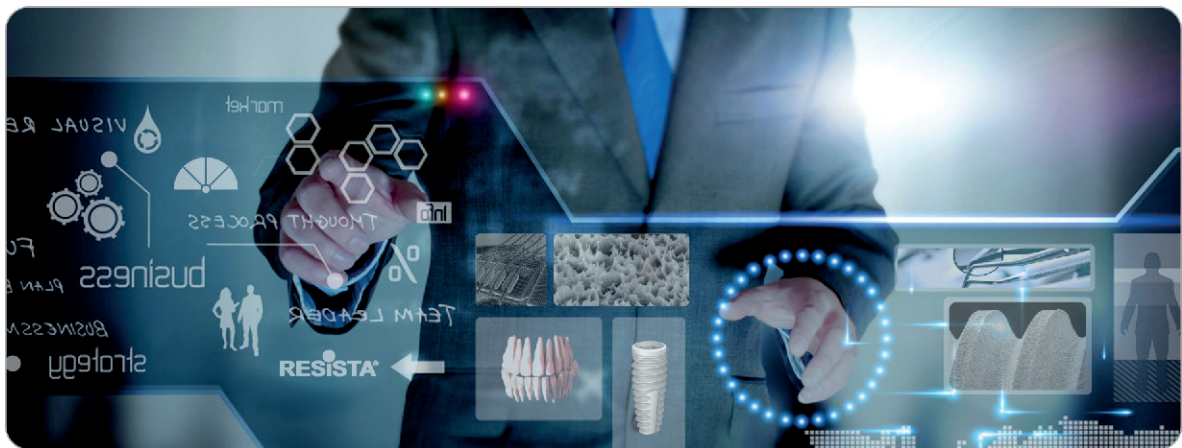

RESEARCH & DEVELOPMENT - The R&D Resista Group's program stems from indications from the clinical world combined with our experience in the field of implantable medical devices.

Due to the use of 3D modeling programs and sophisticated computer systems, we simulate the final geometries and the design, developing the rapid prototyping phases of the projects.

INNOVATIONS - Resista Group is structured to meet all the needs of the metal-implant with an advanced conception technology, prototyping and final product engineering to arrive at innovative solutions. Validation is carried out in collaboration with accredited Research Institutes following the International Standards Requirements.

QUALITÀ DI PROGETTO E PROCESSO - ICIM Spa ha certificato la **Ing. C. A. Issoglio & C. S.r.l.** in accordo alle normative **UNI EN ISO 9001** e **UNI EN ISO 13485** nel rispetto di tutte le normative vigenti relative ai prodotti e servizi offerti.

Ogni dipendente che ricopre differenti ruoli (tecnici, ingegneristici, amministrativi, commerciali, operatori meccanici, ecc), segue linee guida ed obiettivi per un unico fine: il miglioramento continuo.



OBIETTIVO PRINCIPALE - La soddisfazione del cliente è il nostro obiettivo. Il fattore vincente è la capacità dell'azienda a risolvere nel breve qualsiasi tipo di richiesta.

Il supporto tecnico fornito dagli specialisti di prodotto, la disponibilità, l'efficienza e la cordialità sono il punto di forza della nostra struttura.



PROJECT AND PROCESS QUALITY - ICIM Spa certified **Ing. C. A. Issoglio & C. S.r.l.** in accordance with **UNI EN ISO 9001** and **UNI EN ISO 13485** in compliance with all current regulations relating to the products and services offered. Every employee covering different roles (technical, engineering, administrative, commercial, mechanic operators, etc.), follows guidelines and objectives for a single purpose: continuous product improvement.

MAIN OBJECTIVE - Customer satisfaction is our objective. The winning factor is the company's ability to quickly resolve any type of request. The technical support provided by Product Specialists, availability, efficiency and friendliness are the strengths of our structure.

the project

CONCETTI BIOMECCANICI - Il successo della metodica implantare **Resista Group** è frutto di approfonditi studi sul design dei prodotti e sulla tecnologia di produzione. I risultati clinici a lungo termine sono, infatti, fortemente influenzati dalla precisione e dalla qualità.

Il **processo produttivo** viene eseguito da operatori altamente qualificati che, con l'ausilio dei sistemi elettronici CNC automatizzati, riescono ad ottenere risultati ottimali e riproducibili.



Le tolleranze di lavorazione, soprattutto negli **accoppiamenti protesici**, sono il nostro **gold standard** e vengono confinate tra i **7 - 10 µm**.

MATERIALI - Gli impianti sono realizzati in **Titanio ASTM Gr 4** (Norm. ISO 5832/2), le viti di ritenzione e le componenti protesiche sono realizzate in **Leghe di Titanio ASTM Gr 5** (Norm. ISO 5832/3).



BIOMECHANICAL CONCEPTS - The **Resista Group** method success is the result of several product design studies and the high technology applied in the production. The precision and reliability of the implant has a strong influence on the long term clinical success.

The **manufacturing process** is carried out by high qualified operators, skilled enough to obtain optimal and reproducible results with the use of electronically controlled CNC machinery. The machinery tolerances, especially in **prosthetic connections**, are our **gold standard** and are between **7 - 10 µm**.

MATERIALS - The implants are made of Titanium ASTM Gr. 4 (ISO Standard 5832/2) and the screws and prosthetic components are made of Titanium ASTM Gr. 5 (ISO Standard 5832/3).

TRATTAMENTI DI SUPERFICIE - Il processo di micro-sottrazione non contaminata, doppia acidificazione **DAE** (Double Acid Etching), modifica la micro rugosità degli impianti (**Ra, Rq**) texturizzando la superficie e massimizzando la bagnabilità ed il biomimetismo.

Il trattamento di superficie ed il processo di decontaminazione, brevettati da **Nobil Bio Ricerche**, sono in grado di migliorare le proprietà bio-chimiche degli impianti dentali **Resista**.

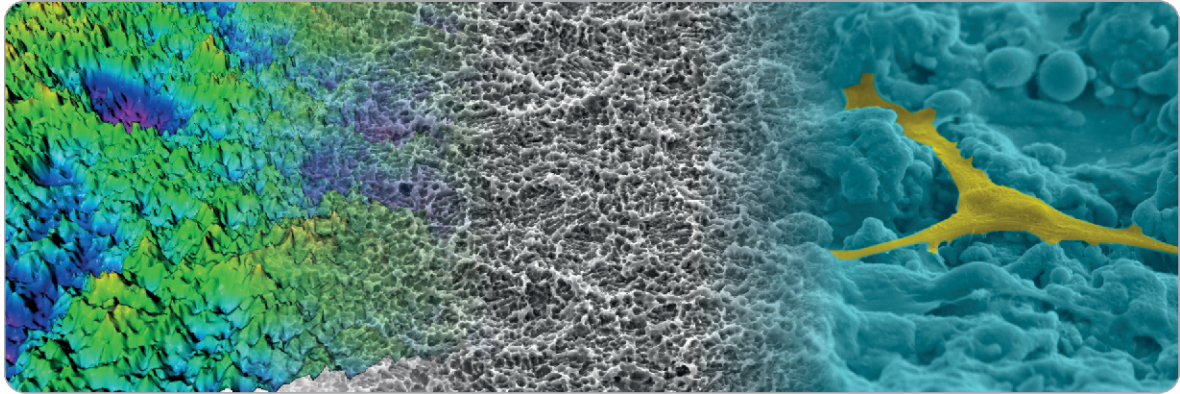

SISTEMA QUALITÀ - L'azienda è certificata in accordo alle norme **UNI EN ISO 9001** e **UNI EN ISO 13485** e ha ottenuto la marcatura **CE** sui propri dispositivi medici in accordo alla Direttiva Europea 93/42/CEE e ss.mm.ii. nel rispetto delle armonizzate di riferimento.

L'impegno è costante nel mantenimento della conformità.



SURFACE TREATMENTS - The non-contaminant micro-subtraction process, **DAE** (Double Acid Etching), changes the implant micro roughness (**Ra, Rq**) and the surface texture maximizing the wettability and biomimetic properties. The new surface treatment and decontamination process are patented by **Nobil Bio Ricerche** improving the bio-chemical properties of the implants.

QUALITY SYSTEM (QS) - UNI EN ISO 9001 and **UNI EN ISO 13485** in compliance of Medical Devices Directives. We are qualified in the design and in the production management of dental implants, dental prosthesis, intraligamental anesthesia syringes and abrasive discs.

micro geometry

Il trattamento di superficie Micro-Nano Ruvido DAE accelera i processi di guarigione ossea

1. Rimuove i residui organici di lavorazione in combinazione con la Decontaminazione al Plasma d'Argon
2. Arrotonda gli angoli vivi eliminando i micro-difetti
3. Incrementa la superficie e la bagnabilità (idrofilia superficiale), migliorando l'adesione dei primi ponti di fibrina
4. Aumenta l'adesione proteica
5. Massimizza l'adesione cellulare con rugosità Micro-Nano Metriche ideali per l'ancoraggio dei filamenti di actina (filopodi)
6. Cambia la chimica superficiale del Titanio che migliorando in biocompatibilità incrementa la proliferazione e la vitalità cellulare

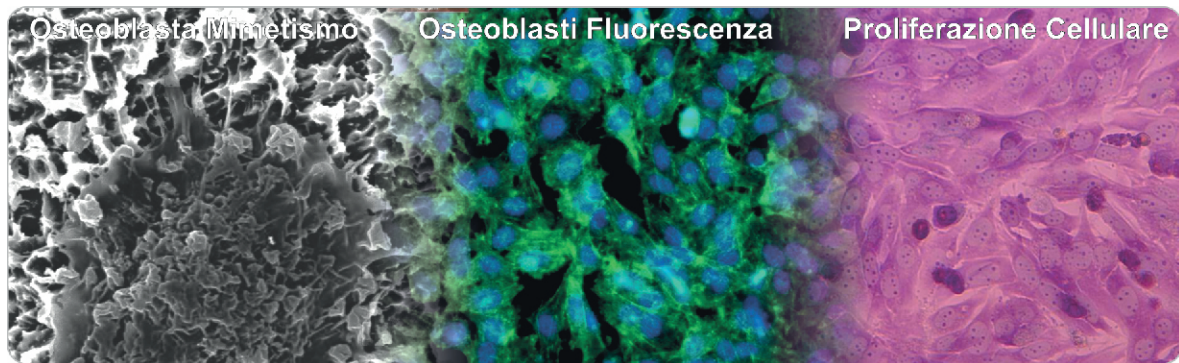

La topografia e la chimica di superficie interagiscono con i processi di differenziazione cellulare

La superficie implantare usa la microtopografia come linguaggio di comunicazione con le cellule del tessuto ospite. La pulizia in reattore al plasma freddo di Argon con confezionamento in ambiente controllato nell'assoluto rispetto delle procedure, gioca un ruolo fondamentale nel controllo delle endotossine adese (principale agente di risposta immunologica alle superfici implantari).

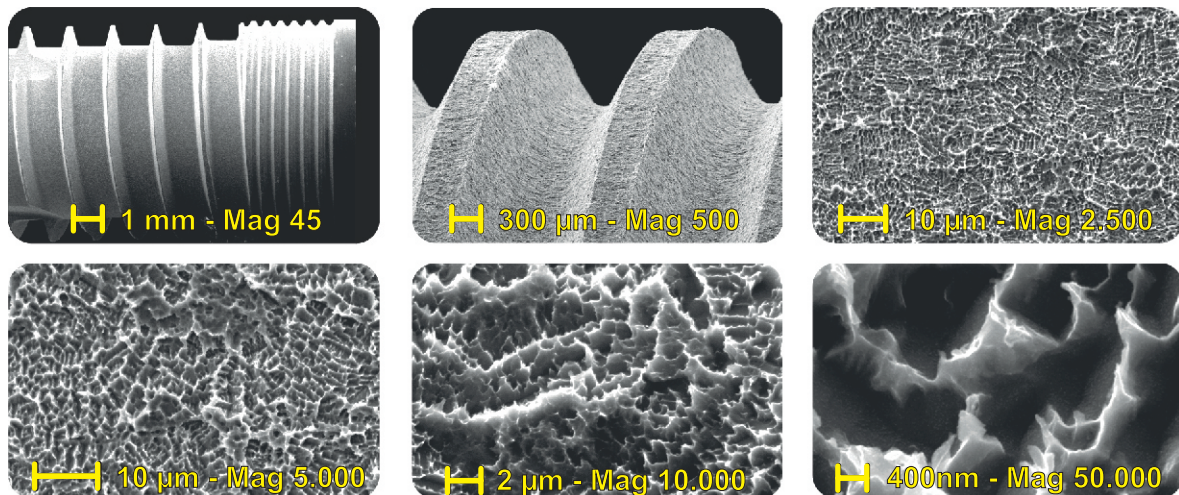

The Micro-Nano Rough DAE surface treatment speed up bone healing processes

1. Removes the manufacturing organic residuals along with Argon Plasma Cleaning
2. Smooths the edge and eliminates the micro-defects
3. Increases surface and wettability (hydrophilicity surface), improving the first fibrin bridges adhesion
4. Increases protein adhesion
5. Maximizes cellular adhesion through the Micro-Nano roughness suitable for actin filaments (phallopod) anchoring
6. Changes the Titanium surface chemical characteristics improving the biocompatibility and increasing the cellular proliferation and vitality

Surface topography and chemistry interact with the cellular differentiation processes

The implant surface uses the microtopography as a communication language with the host tissue cells. The Plasma Argon Cold Cleaning with a controlled-environment packaging at a strict protocol procedures, play a key-role in the control of adhered endotoxins (main immunological response player to implant surfaces).

DISTRIBUZIONE DEL TRATTAMENTO DI SUPERFICIE SULLA FORMA IMPLANTARE

Tutti gli impianti **Resista** presentano un trattamento di superficie localmente differenziato. La logica di distribuzione superficiale del trattamento è dettata dalla posizione endo-ossea dell'impianto che richiede caratteristiche differenti in funzione della presenza, più o meno ravvicinata della componente mucogengivale.

1. **Superficie Machined:** Spazzolata, rettificata e mascherata nel processo di irruvidimento
2. **Superficie Nanoruvida:** Trattamento veloce, nanoruvido con Ra medio inferiore al micron
3. **Superficie Microruvida 3/5 μ :** Trattamento DAE, microruvido con Ra medio tra 3/5 micron
4. **Superficie Microruvida 4/7 μ :** Trattamento DAE lento, microruvido con Ra medio tra 4/7 micron

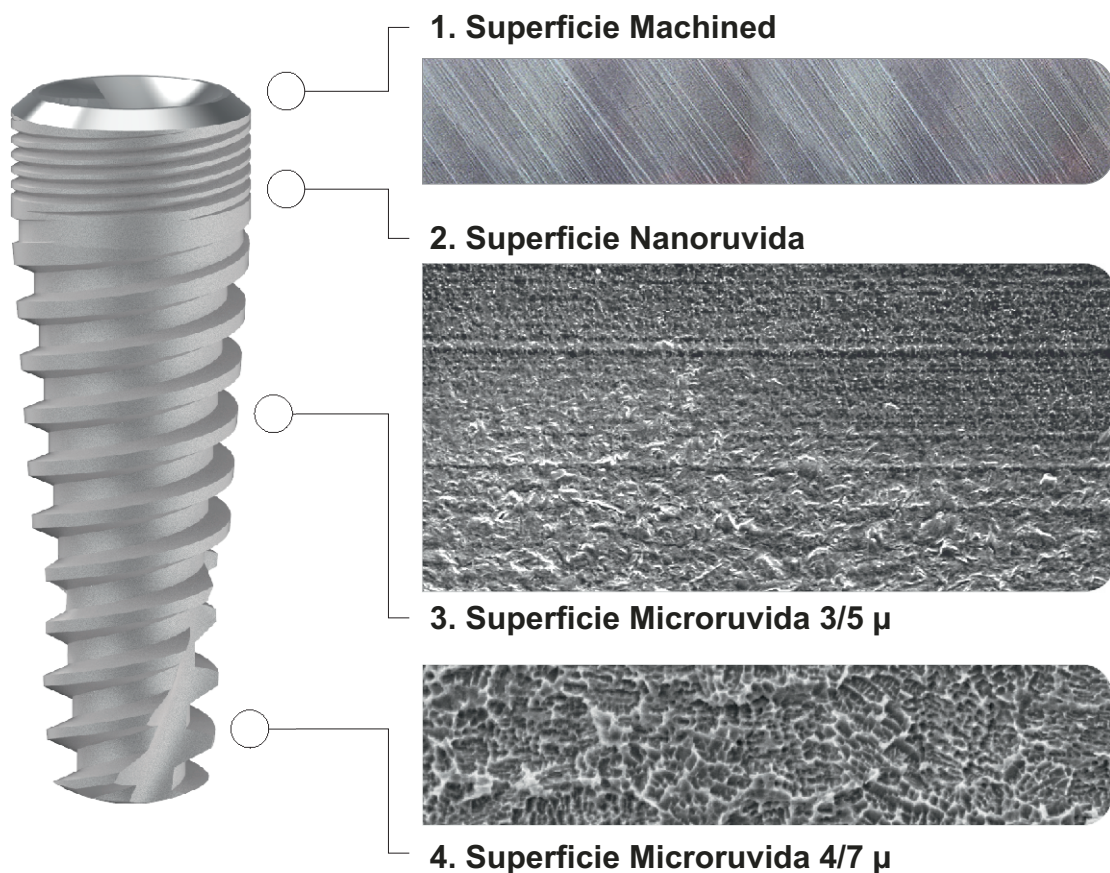

VEGF/VEGF-R/RUNX2 Upregulation in Human Periodontal Ligament Stem Cells Seeded on Dual Acid Etched Titanium Disk

Francesca Diomede, Guya Diletta Marconi, Marcos F. X. B. Cavalcanti, Jacopo Pizzicannella, Sante Donato Pierdomenico, Luigia Fonticoli, Adriano Piattelli and Oriana Trubiani

Materials 2020, 13, 706; doi:10.3390/ma13030706



SURFACE TREATMENT DISTRIBUTION ON IMPLANT'S BODY

All the **Resista's** implants have a surface treatment that is locally differentiated. The logic of surface treatment distribution is dictated by the endo-osseous implant position which requires different characteristics dependin on the muco-gingival component presence around.

1. **Machined Surface:** Brushed, rectify and protected during the roughening process
2. **Nano-rough Surface:** Speedy treatment, nano-rough with average Ra less than one micron
3. **Micro-rough Surface: 3/5 μ :** DAE Treatment, micro-rough with average Ra between 3/5 μ
4. **Micro-rough Surface: 4/7 μ :** DAE Slow Treatment, micro-rough with average Ra between 4/7 μ

PUNTI DI FORZA DELLE LINEE IMPLANTARI RESISTA

- 1. Macro Geometrie:** Vastissima gamma di forme implantari per le differenti necessità in campo chirurgico (Cilindrici, Tapered, Attivi, Short, Mini ed Extra-Larghi)
- 2. Micro Geometrie:** Trattamenti di superficie differenziati (Full, Half e Machined) di ultima generazione (DAE Micro e Nano rugosi), decontaminati in Reattore al Plasma Freddo di Argon.



The Bacterial Anti-Adhesive Activity of Double-Etched Titanium (DAE) as a Dental Implant Surface

Morena Petrini, Alessandra Giuliani, Emanuela Di Campi, Silvia Di Lodovico, Giovanna Iezzi, Adriano Piattelli and Simonetta D'Ercole¹
International Journal of Molecular Sciences 2020, 21, 8315; doi:10.3390/ijms21218315

- 3. Mounter Multifunzione:** 4 componenti in un unico articolo (Mounter, Transfer, Abutment e Mounter per Chirurgia Computer Guidata) per massimizzare la resa ed ottimizzare i costi.
- 4. Componenti protesiche:** Vastissima gamma di varianti protesiche con tolleranze di lavorazione sulle connessioni di 7 micron, con profili emergenti curvilinei, connessioni piane e coniche, platform switching, viti in Titanio Dorate e rivestimenti in PVD TiN (più estetica e minore ritenzione di placca).
- 5. Strumentario Chirurgico:** Frese chirurgiche **3-Tech**, massima efficienza, minima invasività, basso coefficiente di attrito, tecnologia **PRO MSD** per applicazione osseo-densificante in senso antiorario, lunga durata, perfetta visibilità delle tacche laser e stop chirurgici millimetrati.



THE RESISTA'S IMPLANT LINE STRONG POINTS

- 1. Macro Geometry:** A vast range of implant shapes for different surgical needs (Cylinder, Tapered, Active, Short, Mini and Extra-Large)
- 2. Micro Geometry:** Last Generation Differentiated Surface (Full, Half and Machined) treated (DAE Micro and Nano rough), decontaminated in Argon Cold Plasma Reactor.
- 3. Multifunctional Mounter:** 4 components in a single article (Mounter, Transfer, Abutment and Mounter for Computer Guided Surgery) to maximize result and minimize costs.
- 4. Prosthetic Parts:** A very wide range of prosthetic variants with 7/10 micron machining tolerances on the connection, with emerging curvilinear profiles, flat and conical connections, platform switching, golden titanium screws and PVD TiN coatings (more aesthetic and less retention of dental plaque).
- 5. Surgical Instruments:** Surgical Drills **3-Tech**, maximum efficiency, minimum trauma, smaller friction coefficient, **PRO MSD** technology for counterclockwise bone densifying application long, lasting resistance, perfect visibility of laser marking and surgical millimeters stop.

COERENZA E LOGICA NEL RAPPORTO DIAMETRO FRESA/DIAMETRO NOCCIOLINO-IMPIANTO

Le progettazioni della forma degli strumenti rotanti si basa sulla logica coerenza tra la dimensione degli impianti, nell'ingombro esterno, nel nocciolo interno e per la loro capacità di penetrazione.

Gli **impianti cilindrici** della linea **IC** presentano una porzione apicale affusolata per una lunghezza di 3mm. Gli **impianti conici** della linea **IK** presentano una porzione apicale affusolata per una lunghezza di 5mm.

Le frese si presentano rispettivamente con 2 / 3 sezioni apicali, adeguate per una preparazione del tunnel implantare rispetto alla geometria dell'impianto, mantenendo il miglior BIC di interfaccia osso / impianto.

Ogni gradino è fornito di un tagliente affilato per agevolare la penetrazione, minimizzando l'attrito ed il surriscaldamento

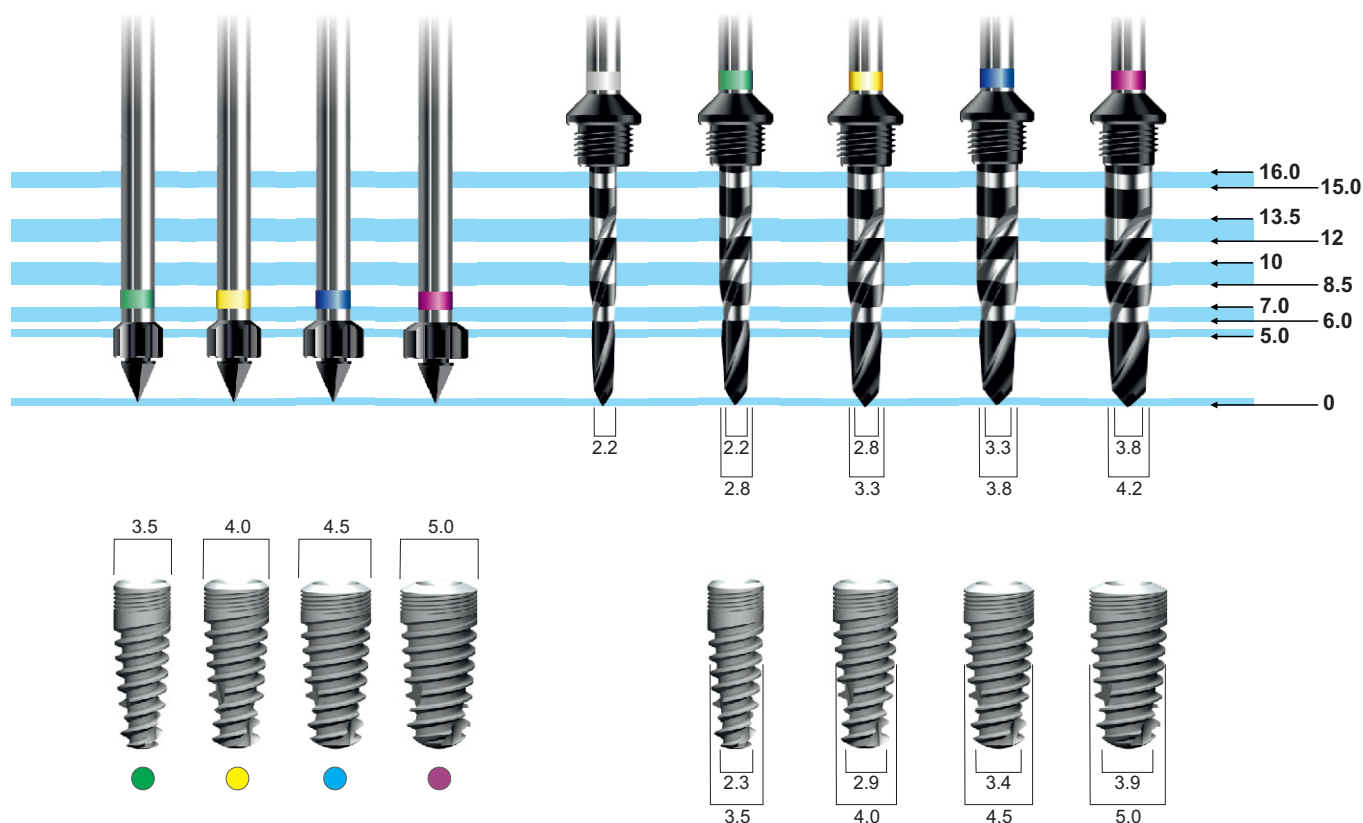

Various bio-mechanical factors affecting heat generation during osteotomy preparation: A systematic review

Chirag J Chauhan¹, Darshana N Shah¹, Foram B Sutaria¹

Indian J Dent Res. Jan-Feb 2018;29(1):81-92. doi: 10.4103/ijdr.IJDR_729_16.



LOGIC RELATION BETWEEN DRILL AND IMPLANT CORE

The rotary instruments design and shape is based on the logical coherence between the implants size, in the external dimensions, internal core and their penetration properties.

The **IC line Cylindrical Implants** have a tapered apical portion 3mm long. The **IK line Conical Implants** have a tapered apical portion 5mm long.

The drills have respectively 2/3 apical sections, suitable for the implant tunnel preparation, with respect to the implant geometry, maintaining the best bone implant contact (BIC).

Each step drill is equipped with a sharp cutting edge to facilitate penetration, minimizing friction and overheating.

IL CONDIZIONAMENTO DEI PROTOCOLLI CHIRURGICI

Le geometrie implantari differenziate nella macro/micro forma, prevedono applicazioni diverse sia in funzione delle necessità chirurgico/protesiche (carico immediato, carico precoce o carico posticipato) sia in base alle condizioni della componente ossea/anatomica del paziente da riabilitare.

Tuttavia, si richiedono spesso indispensabili manovre chirurgiche e protocolli alternativi per migliorare le prestazioni implantari in funzione delle caratteristiche morfologiche delle strutture ossee residue.

La riuscita di tali manovre, come risultato di applicazioni combinate di strumenti e protocolli personalizzati, rappresenta la differente risposta al problema in relazione alle personali capacità operatorie ed alla presenza più o meno marcata di strumenti e mezzi adeguati all'applicazione delle stesse.

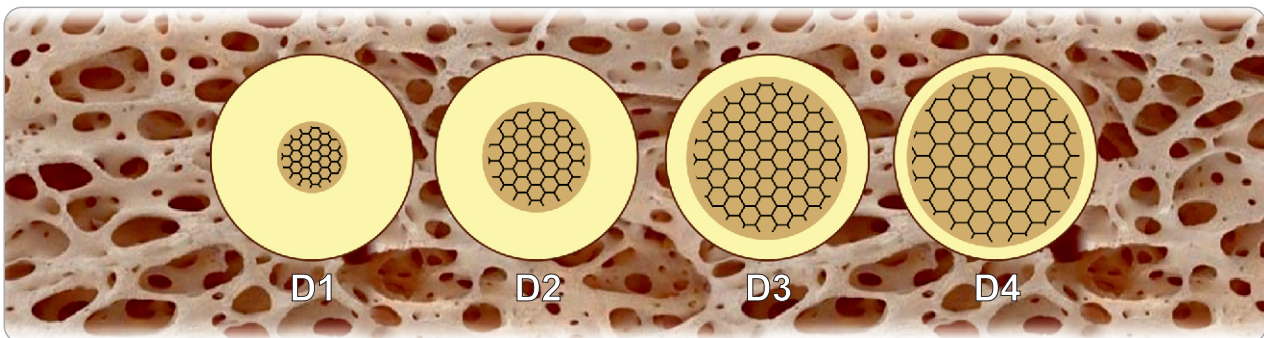

✓ Bone classification: clinical-histomorphometric comparison

Trisi P, Rao W. - Clin Oral Implants Res. 1999 Feb;10(1):1-7. doi: 10.1034/j.1600-0501.1999.100101.x.

OSSEODENSIFICAZIONE MECCANICA IN ROTAZIONE ANTIORARIA

L'osseodensificazione tramite strumenti rotanti è una recente tecnica chirurgica per la preparazione del sito implantare che può essere associata a differenti protocolli, applicabili in quelle particolari condizioni anatomiche dove la qualità ossea risulta scarsa e con dimensioni verticali / orizzontali insufficienti.

Questo approccio di osseo-condensazione osteotomica non sottrattiva, genera un aumento della densità ossea peri-osteotomica, con il risparmio del tessuto stesso e l'incremento della stabilità primaria implantare.



THE CONDITIONING OF SURGICAL PROTOCOLS

The differentiated implant geometries in the macro/micro shape provide for different applications, both according to the surgical/prosthetic requirements (immediate loading, early loading or postponed loading) and according to the conditions of the bone/anatomical component of the patient who needs rehabilitation. However, surgical maneuvers and alternative protocols are often required to improve implant performance, according to the morphological characteristics of the residual bone structures.

The success of these maneuvers, that is often the result of a customized tools and protocols combination, represents the different response to the problem in relation to the personal operating skills and the presence of tools suitable for their application.

MECHANICAL OSSEODENSIFICATION IN ANTI-CLOCKWISE ROTATION

The osseodensification using rotary instruments is a recent surgical technique for the implant site preparation that can be associated with different protocols; these protocols can be used in those particular anatomical conditions such as poor bone quality and insufficient vertical / horizontal dimensions.

This non-subtractive osteotomic bone-condensation approach produces an increase in peri-osteotomic bone density, saving the tissue and increasing the primary implant stability.

PRO MSD drilling technology

FRESE CHIRURGICHE RESISTA PRO MSD - Modular Surgical Drilling

Le Frese Chirurgiche Modulari a geometria variabile sono frese elicoidali a 3 sezioni con spoglia raggiata progressiva, utilizzabili in senso **orario** ed **antiorario**.

Il diametro di ogni fresa varia, con un rapporto costante, di 0,4mm (30/34/38/42/46/50), permettendo così all'operatore la scelta di utilizzo in funzione della qualità ossea (sovra-preparazione o sotto-preparazione).

Tutte le frese sono rivestite con un coating di lubrificante solido in diamante sintetico DLC (Diamond Like Carbon) che massimizza le prestazioni in termini di resistenza meccanica e riduzione dell'attrito.

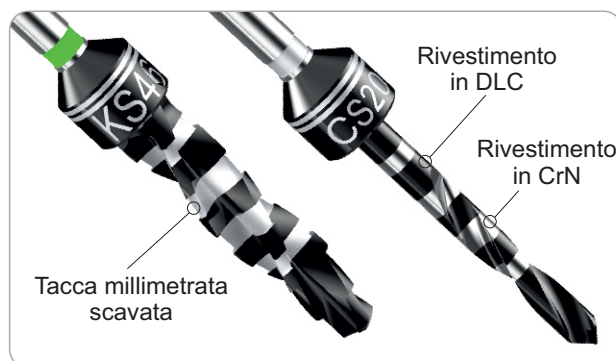
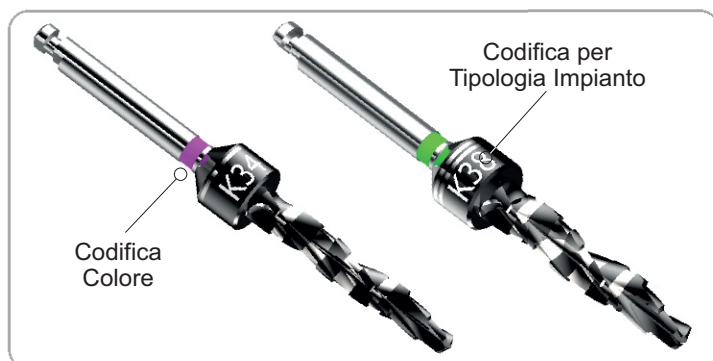

ROTAZIONE ANTIORARIA

La rotazione antioraria, invertendo le forze in gioco, genera 3 effetti differenti sulla pratica chirurgica di preparazione del tunnel implantare, che possono rivoluzionare la logica di fresatura conosciuta.

- 1) Spinta anteriore e laterale dell'osso asportato dalla punta più tutti i liquidi in gioco, sangue e fisiologica.
- 2) Espulsione ad "effetto martello" della fresa, con un miglioramento del controllo verticale.
- 3) Riduzione dell'efficienza di taglio a salvaguardia delle parti anatomiche sensibili.

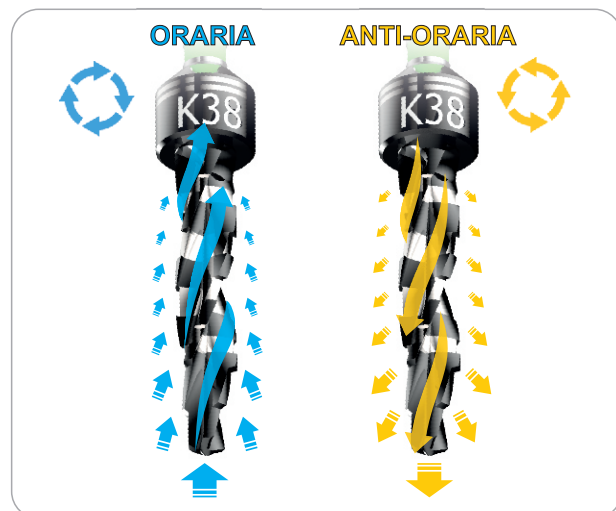

RESISTA PRO MSD SURGICAL DRILLS - Modular Surgical Drilling

The Modular Surgical Drills with variable geometry are 3-section helicoidal drills with progressive radius rake, that can be used clockwise and anticlockwise.

The diameter of each drill changes according to a constant ratio of 0.4mm (30/34/38/42/46/50): this allows the operator to choose the drill according to the bone quality (over-preparation or under-preparation). All the drills are coated with a DLC (Diamond Like Carbon) synthetic diamond solid lubricant that maximizes performance in terms of mechanical strength and friction reduction.

The **anticlockwise rotation**, reversing the involved forces, generates 3 different effects on the implant tunnel perforation, which can revolutionize the known milling logic.

- 1) Anterior and lateral thrust of the bone removed by the tip, and of the liquids as well, blood and physiological water.
- 2) Ejection and "hammer effect" of the drill that produce an improvement in vertical control.
- 3) Reduction of cutting efficiency to protect sensitive anatomical parts.



CONICAL

Impianto dedicato ad un utilizzo in osso di qualità scarsa D3 e D4

Titanio ASTM Gr 5 ELI (Norm. ISO 5832/3) - Lega di Titanio 90% - Alluminio 6% - Vanadio 4%

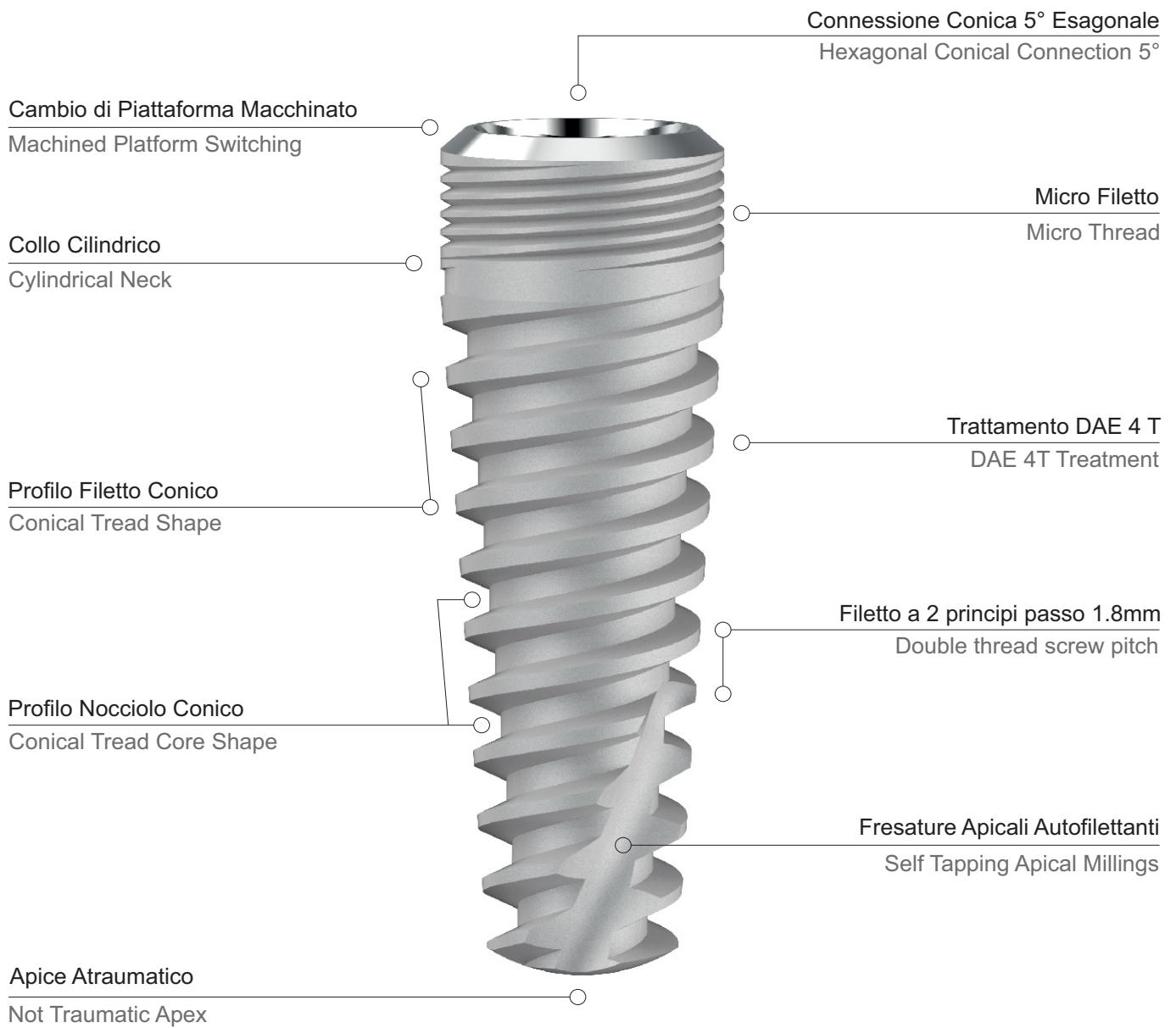

macro morphology

CYLINDRICAL

Impianto universale con indicazioni di utilizzo in osso di qualità D1 - D2 - D3

Titanio ASTM Gr 4 Cold Worked (Norm. ISO 5832/2) - Classe Pura 99%

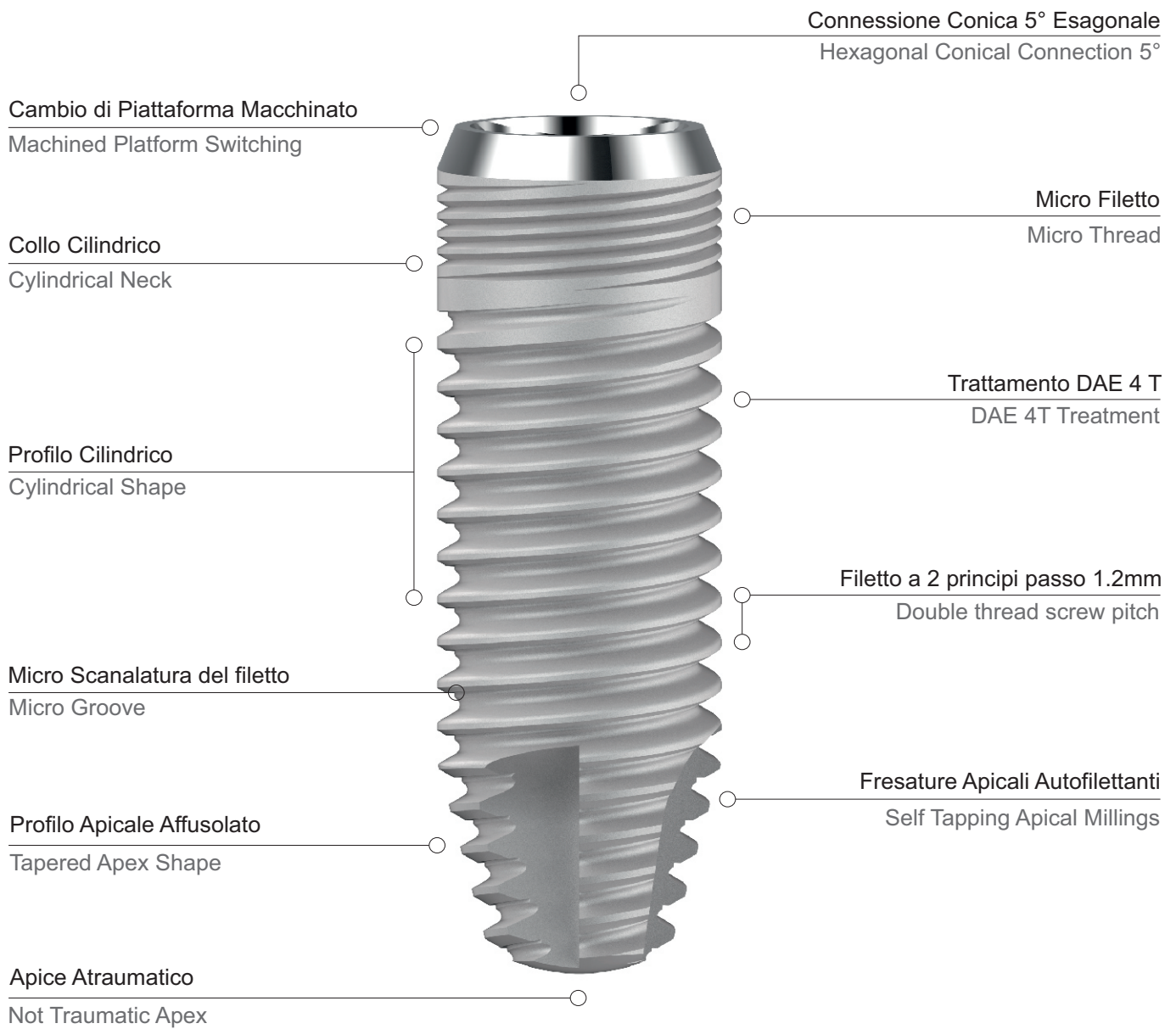

conical connection

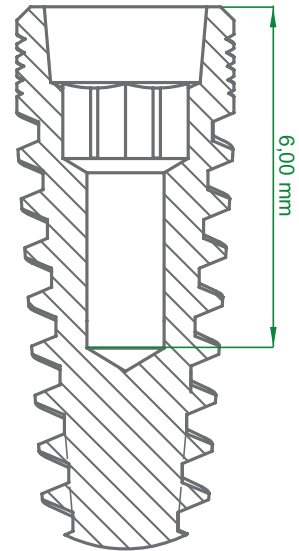
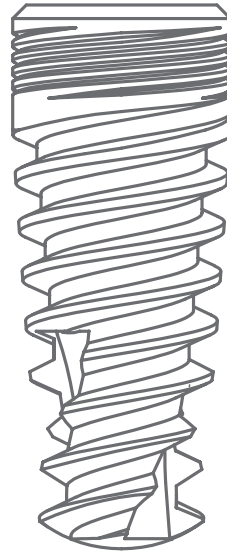

La connessione conica esagonale assicura un aumento della resistenza meccanica al carico extra assiale, maggiore superficie di contatto, maggiore stabilità di connessione tra moncone ed impianto, grazie a una ridotta microcircolazione dei fluidi biologici al suo interno.

La connessione BANP-CE® è costituita da un accoppiamento profondo, composto dalla porzione conica a 5°, un esagono antirotazionale ed una vite di serraggio assiale.

Questa combinazione garantisce una perfetta stabilità del moncone a prescindere dalla lunghezza o dal diametro degli impianti.

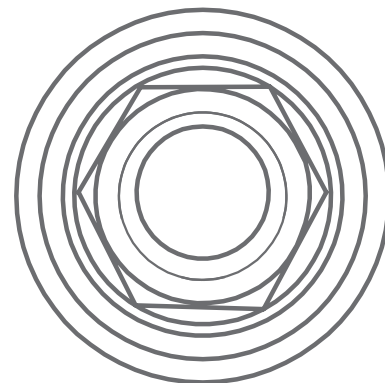
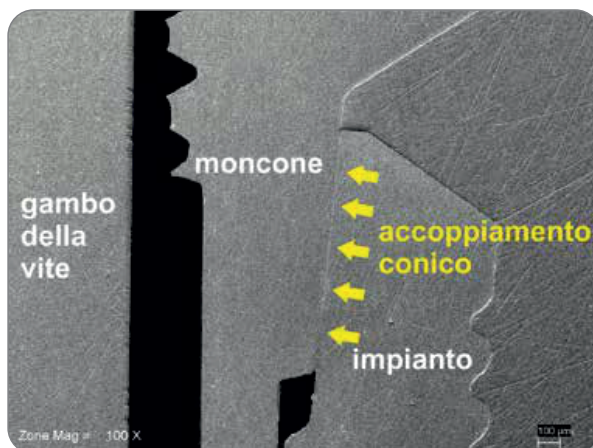

The conical hexagonal connection ensures an increase in mechanical resistance to extra axial load, greater contact surface, greater connection stability between abutment and implant, thanks to a reduced microcirculation of the biological fluids inside.

The BANP-CE® connection it's made of deep mechanical interface, composed of the 5° conical portion, an anti-rotation hexagon and an axial tightening screw.

This combination guarantees perfect stability of the abutment, regardless of the length or implants diameter.

conical connection

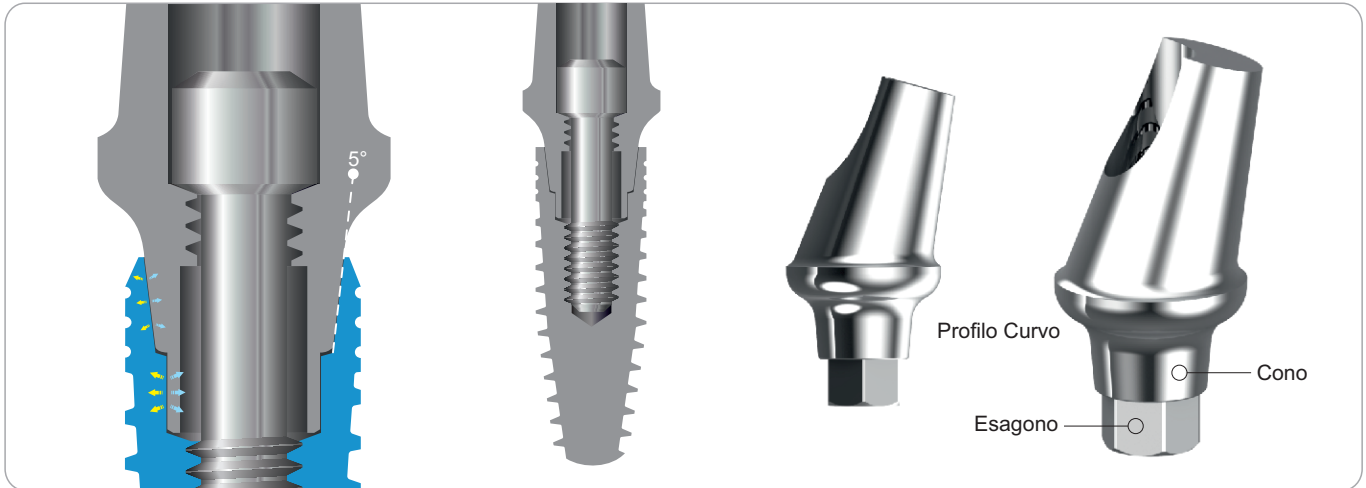

CONNESSIONE CONICA 5° CON ESAGONO ANTIROTAZIONALE

La conicità di 5° sulle pareti del cono maschio/femmina determina una riduzione dell'interfaccia meccanica così intima da conferire un grippaggio diretto, conosciuto come «saldatura a freddo», tra abutment ed impianto.

Questo effetto si attiva completamente alla fine del serraggio protesico della vite passante, raggiungendo i 30 Ncm di forza torcente che garantisce il sigillo batterico riducendo a zero il gap di interfaccia.

Per la rimozione dell'abutment sarà necessario l'utilizzo di una vite di rimozione alternativa, da avvitare in sostituzione di quella originale, con la sola funzione di spingere dall'interno verticalmente il moncone e rimuoverlo dalla sua posizione grippata.



5° CONICAL CONNECTION WITH ANTIROTATIONAL HEXAGON

The 5° on the male/female cone walls, causes a so close reduction of the mechanical interface that confers a direct binding (known as "cold welding") between the abutment and the implant.

This effect is fully activated at the end of the prosthetic tightening of the passing screw, that reaches 30 Ncm of torque and guarantees a bacterial seal through the reduction of the interface gap to zero.

In order to remove the abutment it will be necessary to use an alternative removal screw, that needs to be screwed in the original one place: its unique function is to push the abutment from the inside vertically and to remove it from its bound position.

APPROCCIO CHIRURGICO SUBCRESTALE

SUBCRESTAL SURGICAL APPROACH

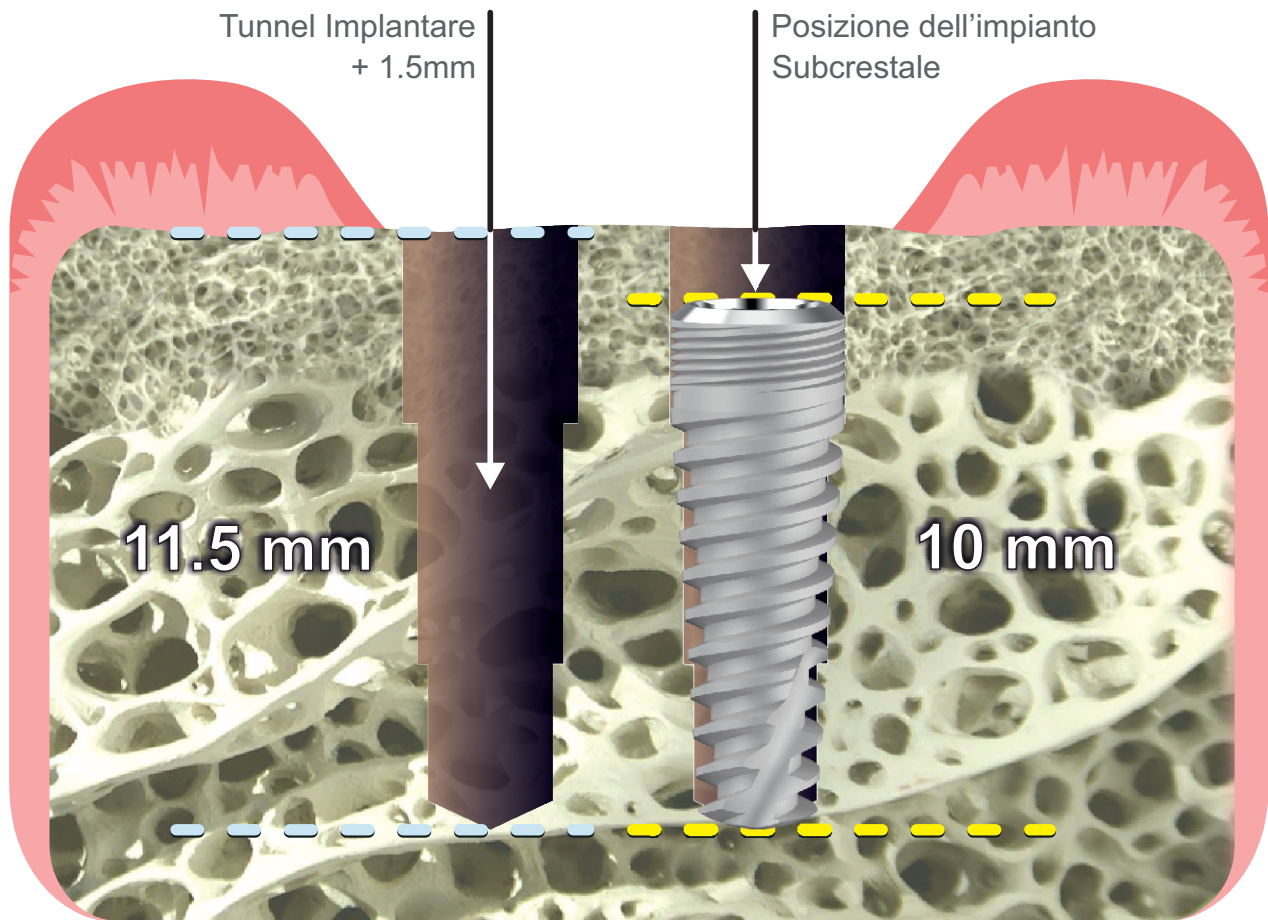

Influence of subcrestal implant placement compared with equicrestal position on the peri-implant hard and soft tissues around platform-switched implants: a systematic review and meta-analysis.

Valles C, Rodríguez-Ciurana X, Clementini M, Baglivo M, Paniagua B, Nart J.

Clin Oral Investig. 2018 Mar;22(2):555-570. doi: 10.1007/s00784-017-2301-1. Epub 2018 Jan 8.

MARGINAL BONE PRESERVATION PROTOCOL

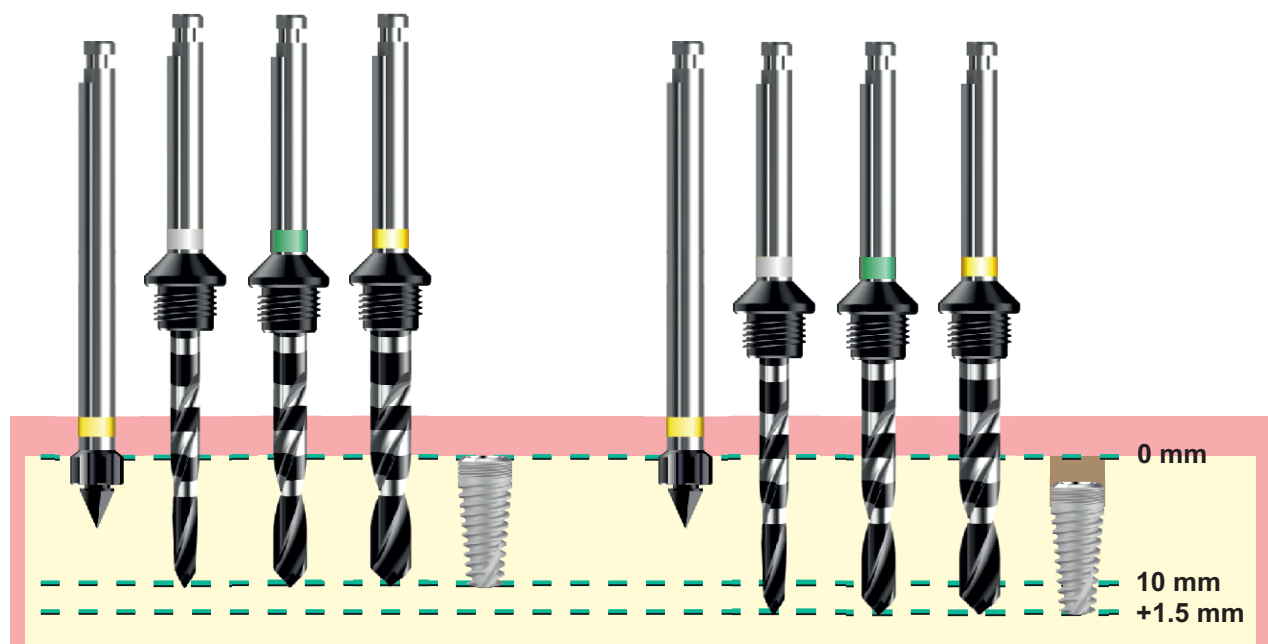

LINEA CONICA ACTIVE

CONICAL CONNETION

PROTESIZZAZIONE UNICA

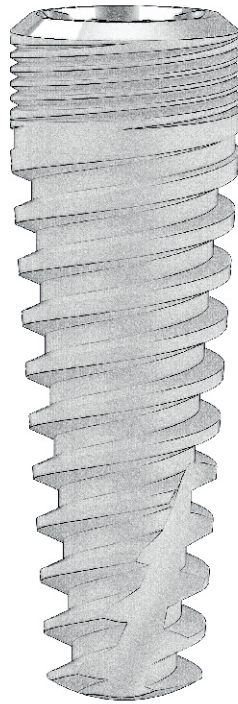

IM

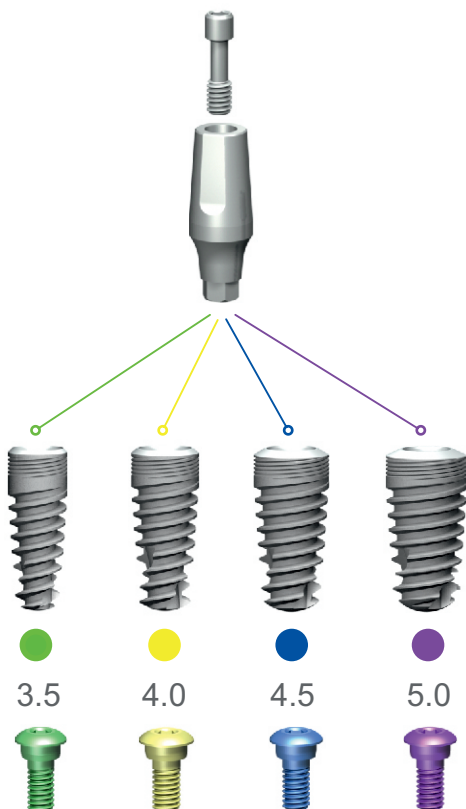

IMPIANTO
SENZA MOUNTER
MOUNTERLESS

TAPERED SHAPE MOUNTERLESS

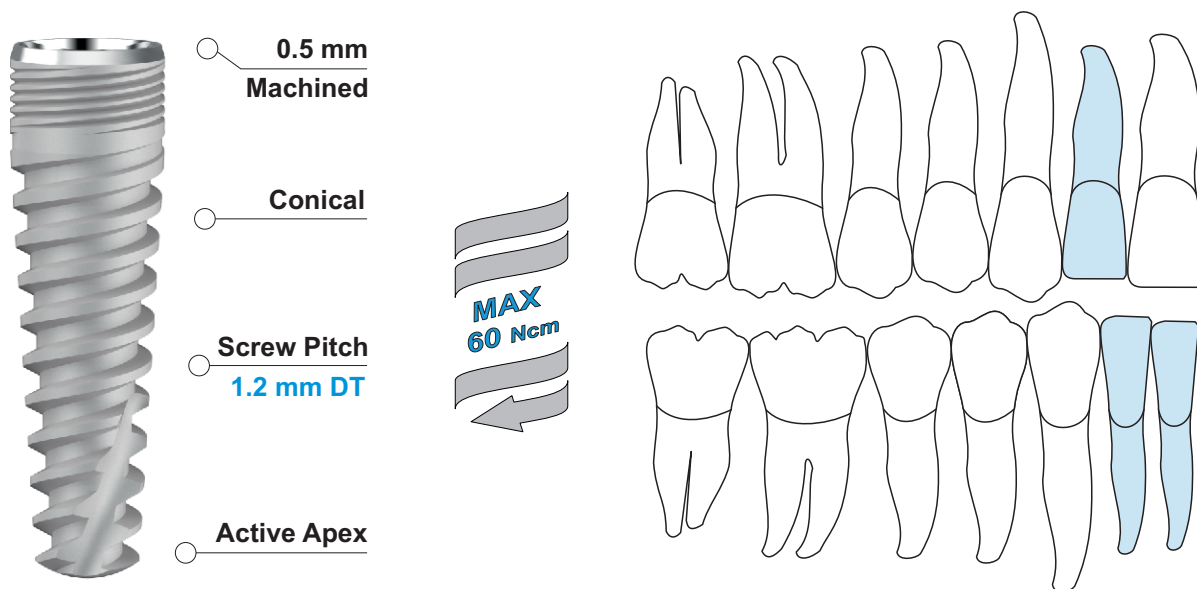

CODE	IMPLANT	LENGTH	PLATFORM	APEX
IM 3585	Ø 3.4	8.5 mm	Ø 3.5	Ø 2.3
IM 3510	Ø 3.4	10 mm	Ø 3.5	Ø 2.3
IM 3512	Ø 3.4	12 mm	Ø 3.5	Ø 2.3
IM 3513	Ø 3.4	13 mm	Ø 3.5	Ø 2.3

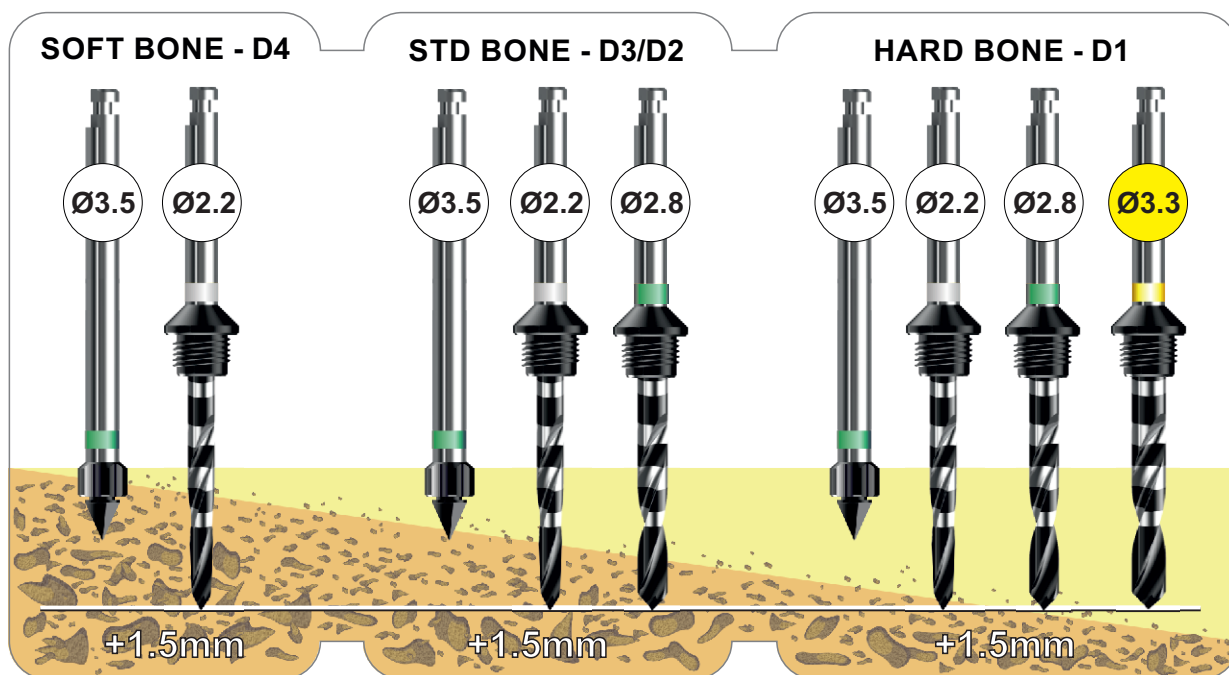

TAPERED SHAPE MOUNTERLESS

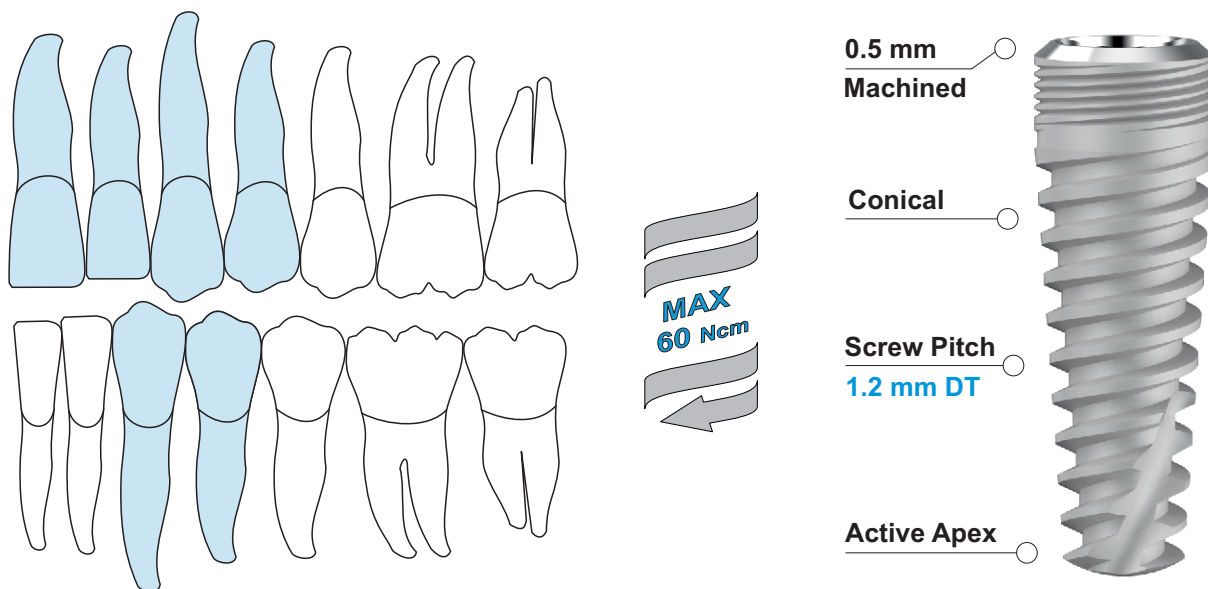

CODE	IMPLANT	LENGTH	PLATFORM	APEX
IM 4085	Ø 3.8	8.5 mm	Ø 4.0	Ø 2.9
IM 4010	Ø 3.8	10 mm	Ø 4.0	Ø 2.9
IM 4012	Ø 3.8	12 mm	Ø 4.0	Ø 2.9
IM 4013	Ø 3.8	13 mm	Ø 4.0	Ø 2.9

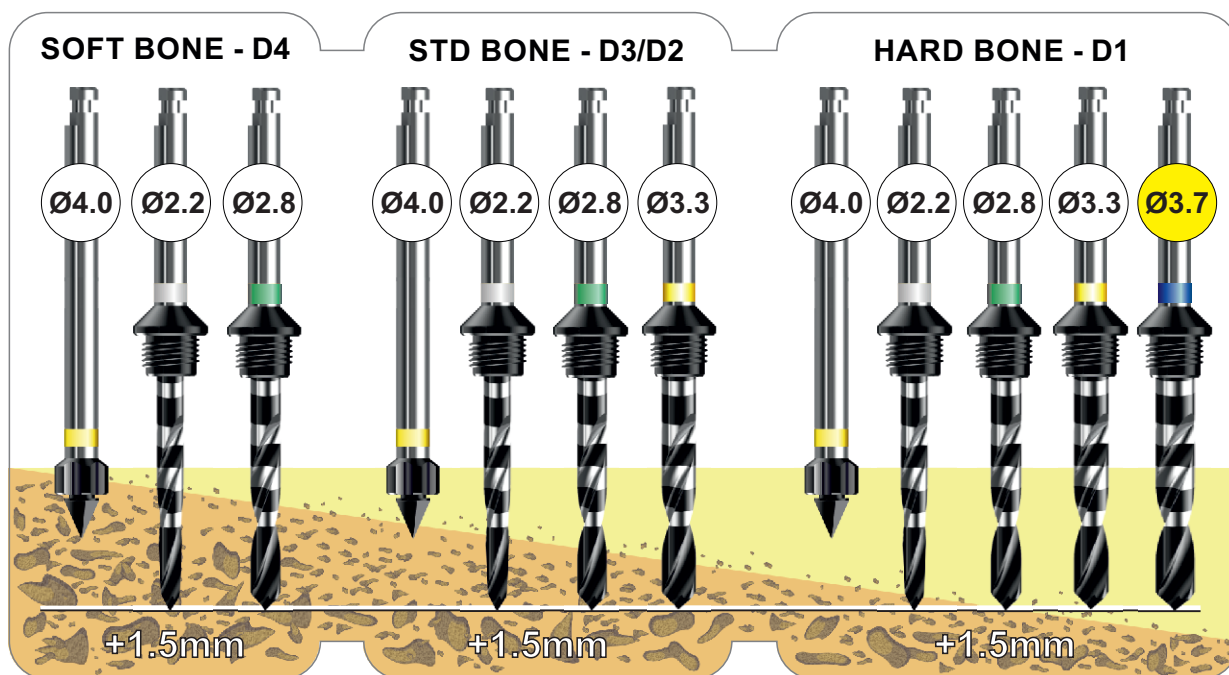

TAPERED SHAPE MOUNTERLESS

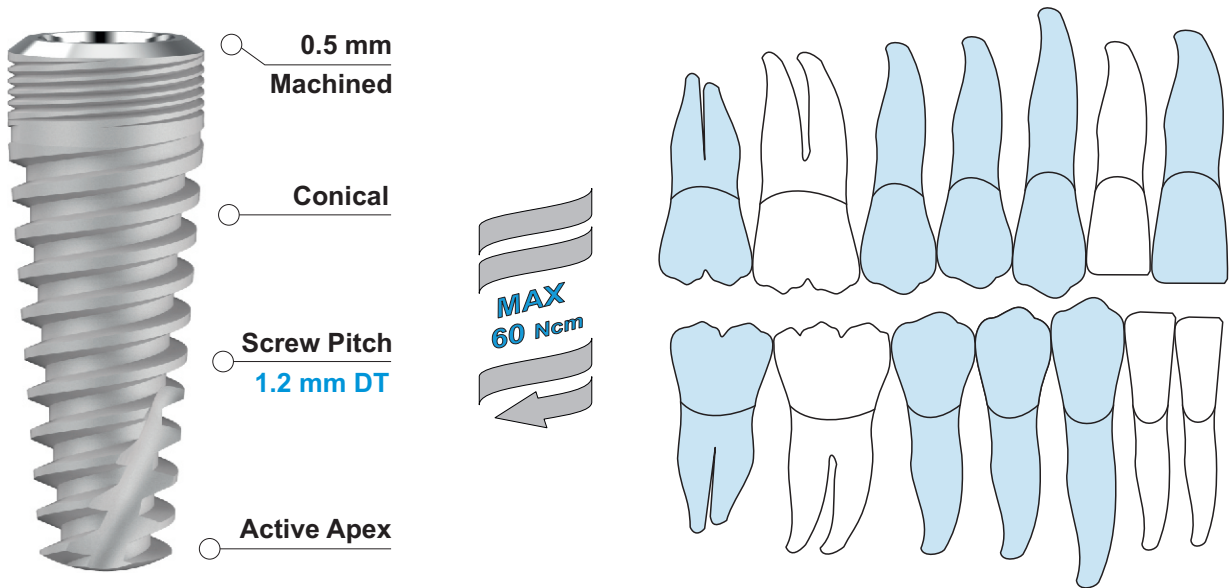

CODE	IMPLANT	LENGTH	PLATFORM	APEX
IM 4585	Ø 4.3	8.5 mm	Ø 4.5	Ø 3.4
IM 4510	Ø 4.3	10 mm	Ø 4.5	Ø 3.4
IM 4512	Ø 4.3	12 mm	Ø 4.5	Ø 3.4
IM 4513	Ø 4.3	13 mm	Ø 4.5	Ø 3.4

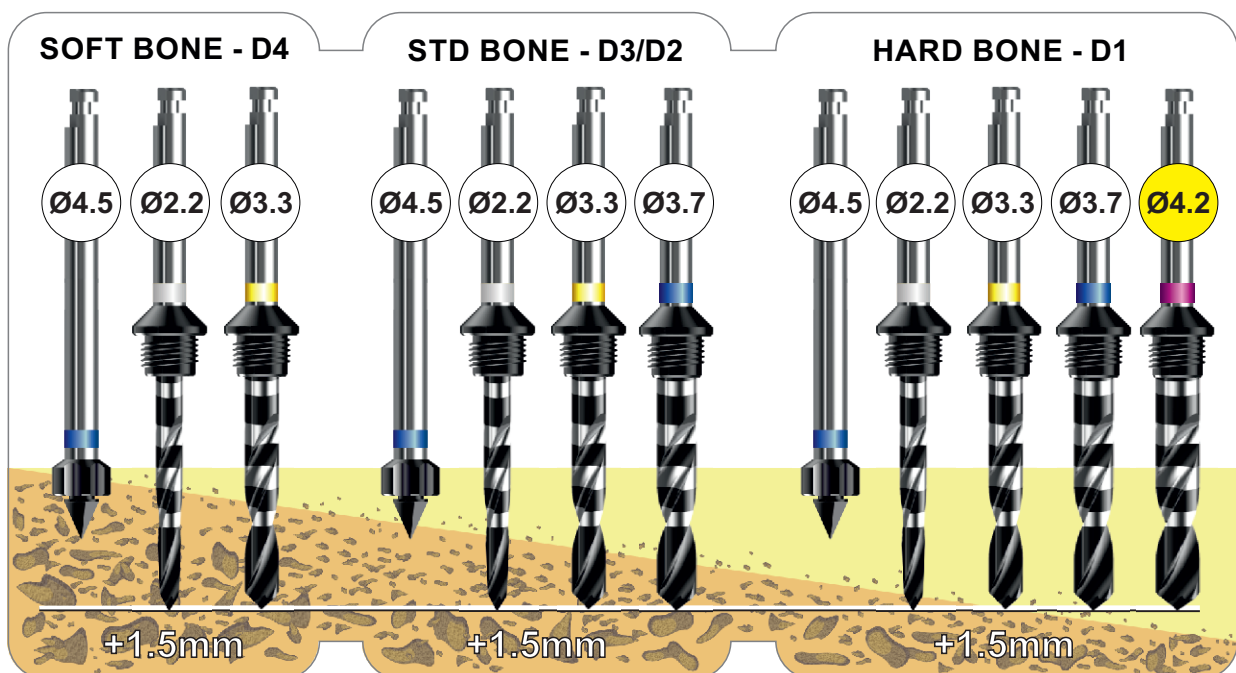

TAPERED SHAPE MOUNTERLESS

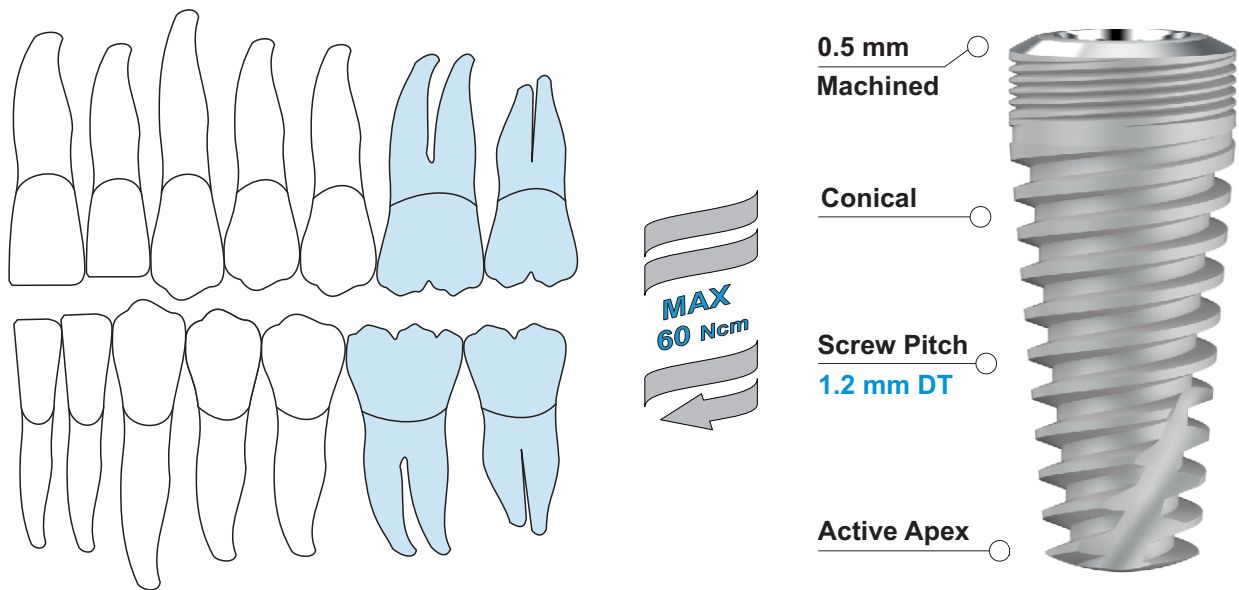

CODE	IMPLANT	LENGTH	PLATFORM	APEX
IM 5085	Ø 4.8	8.5 mm	Ø 5.0	Ø 3.9
IM 5010	Ø 4.8	10 mm	Ø 5.0	Ø 3.9
IM 5012	Ø 4.8	12 mm	Ø 5.0	Ø 3.9
IM 5013	Ø 4.8	13 mm	Ø 5.0	Ø 3.9

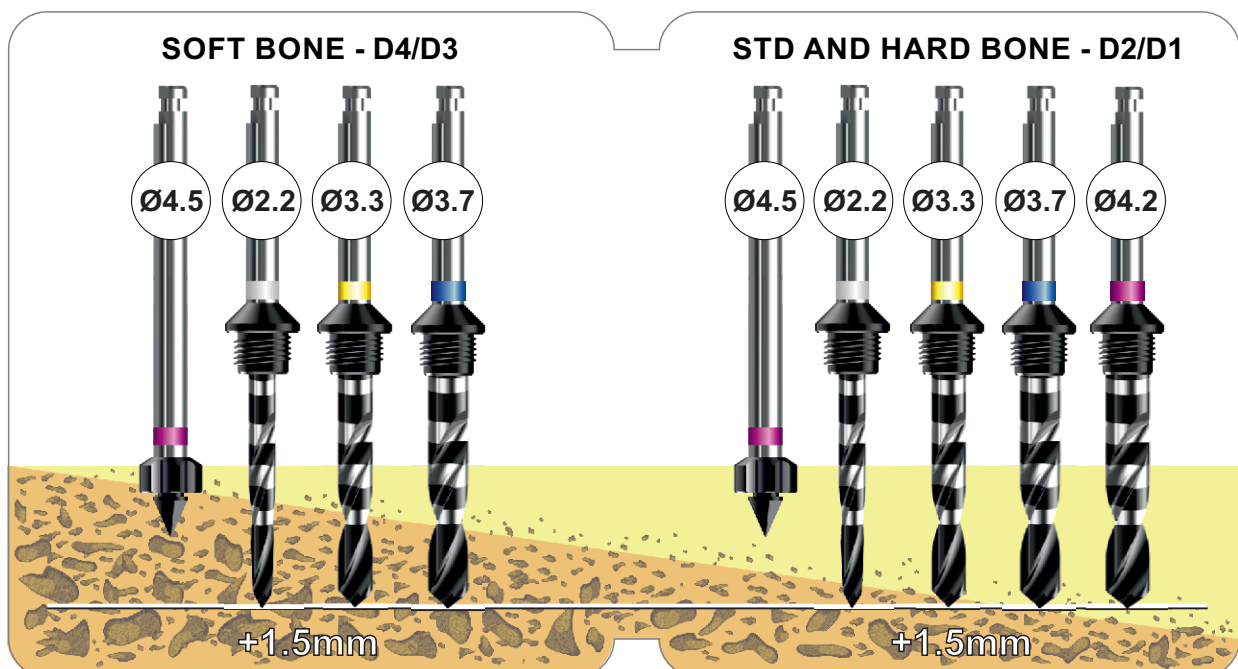

APPROCCIO CHIRURGICO SUBCRESTALE

SUBCRESTAL SURGICAL APPROACH

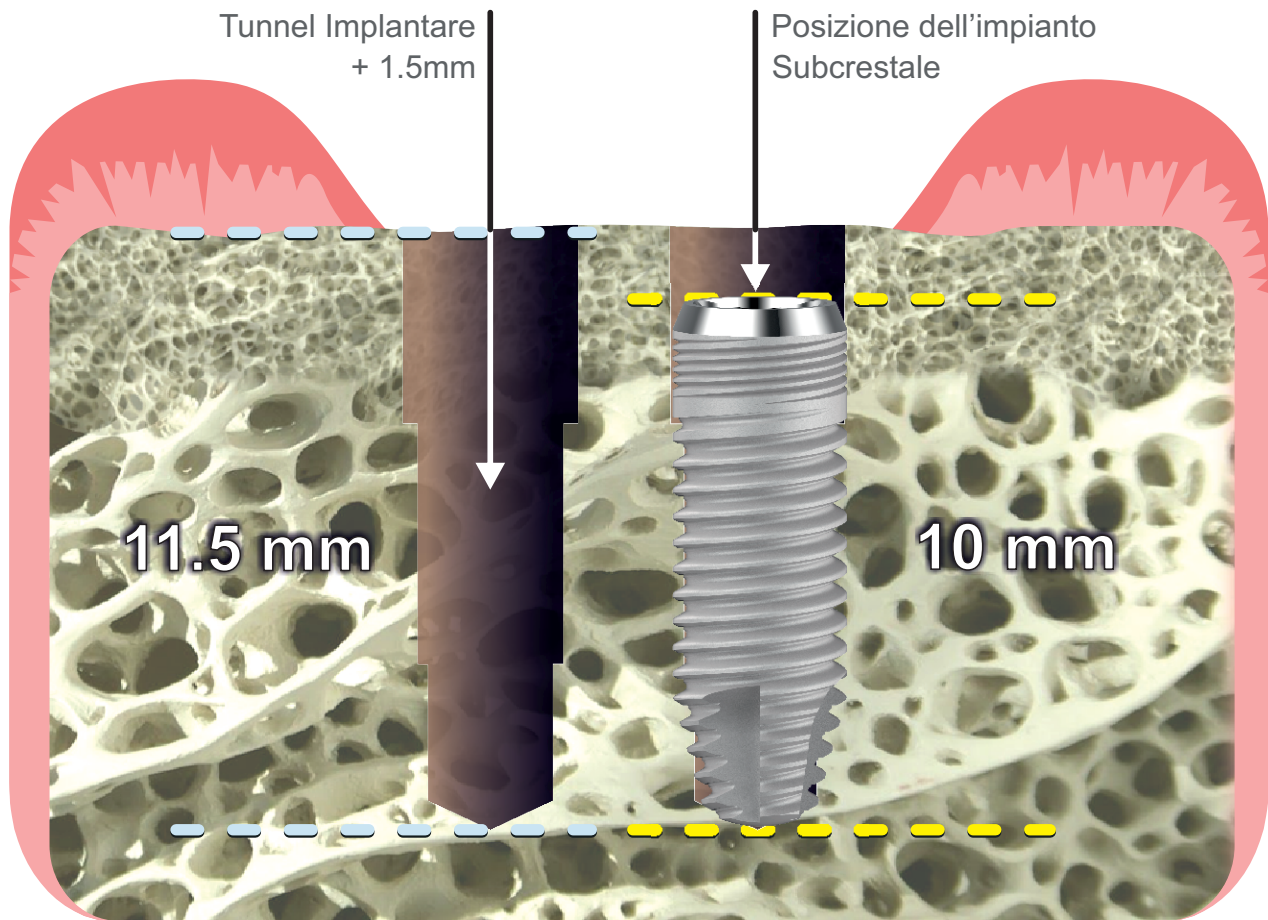

Influence of subcrestal implant placement compared with equicrestal position on the peri-implant hard and soft tissues around platform-switched implants: a systematic review and meta-analysis.

Valles C, Rodríguez-Ciurana X, Clementini M, Baglivo M, Paniagua B, Nart J.

Clin Oral Investig. 2018 Mar;22(2):555-570. doi: 10.1007/s00784-017-2301-1. Epub 2018 Jan 8.

MARGINAL BONE PRESERVATION PROTOCOL

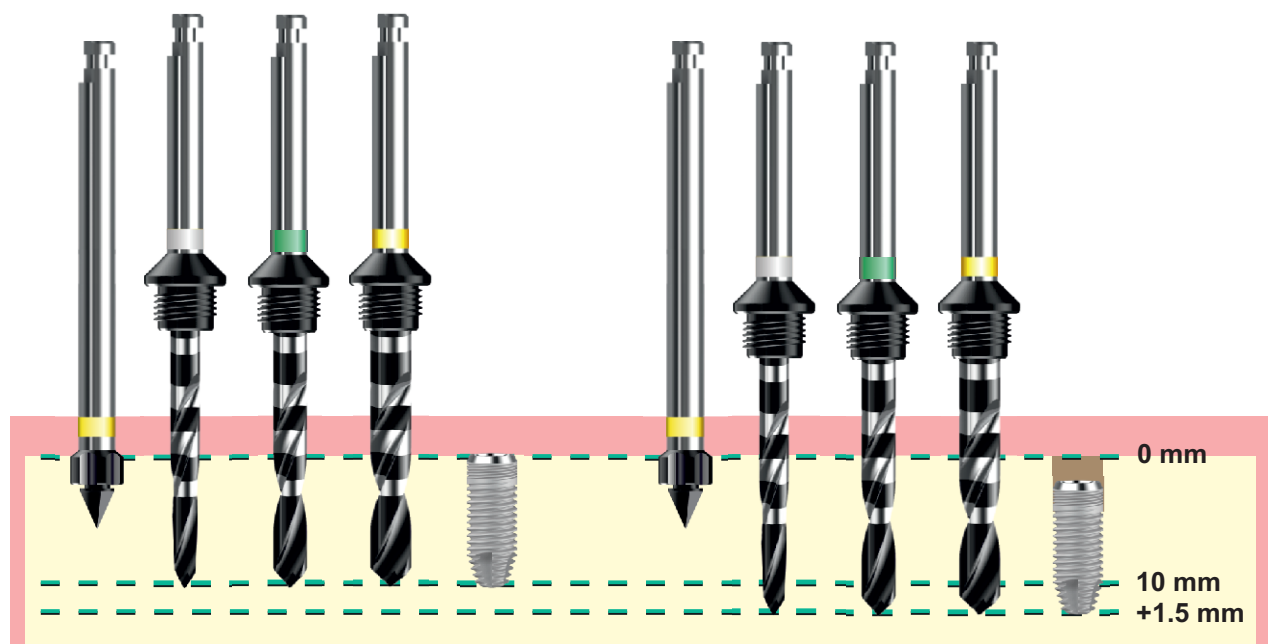

LINEA CILINDRICA TAPERED

CONICAL CONNETION

PROTESIZZAZIONE UNICA

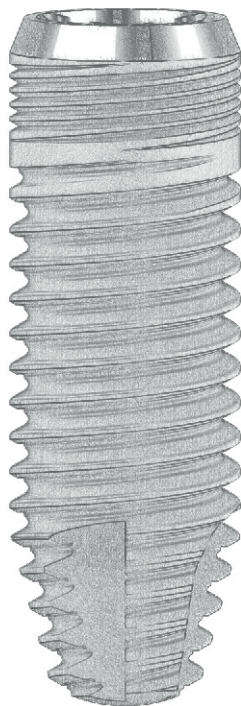

IC

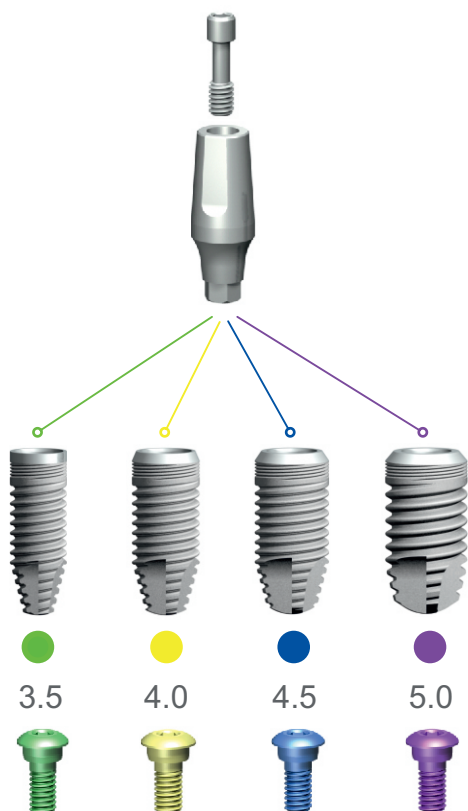

IMPIANTO
SENZA MOUNTER
MOUNTERLESS

TAPERED SHAPE MOUNTERLESS

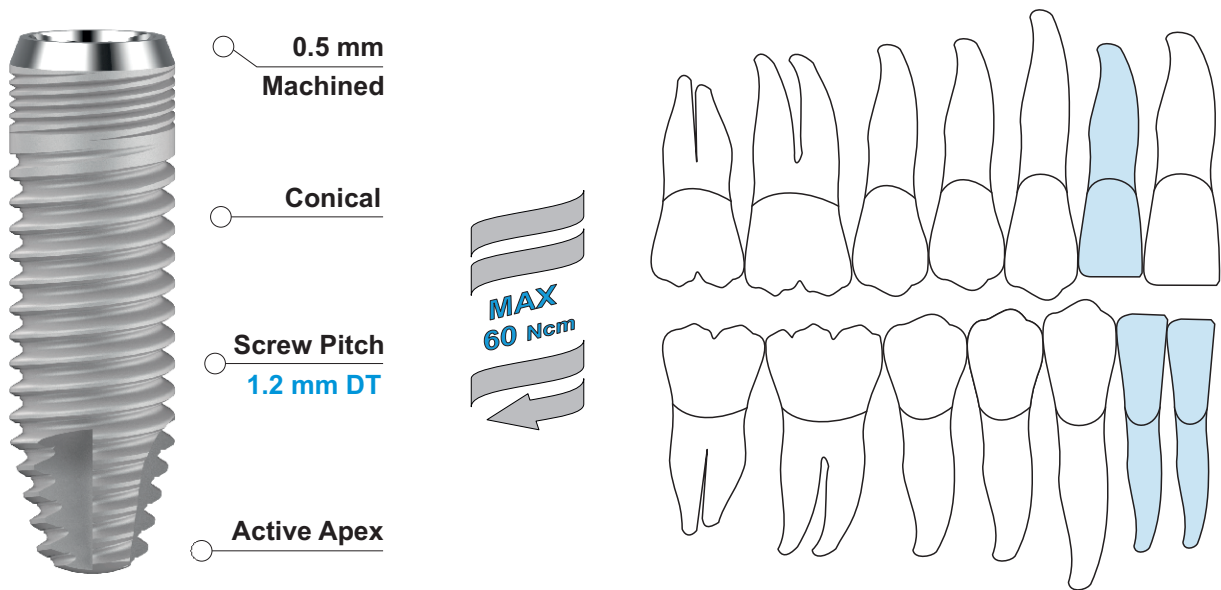

CODE	IMPLANT	LENGTH	PLATFORM	APEX
IC 3585	Ø 3.4	8.5 mm	Ø 3.5	Ø 2.3
IC 3510	Ø 3.4	10 mm	Ø 3.5	Ø 2.3
IC 3512	Ø 3.4	12 mm	Ø 3.5	Ø 2.3
IC 3513	Ø 3.4	13.5 mm	Ø 3.5	Ø 2.3

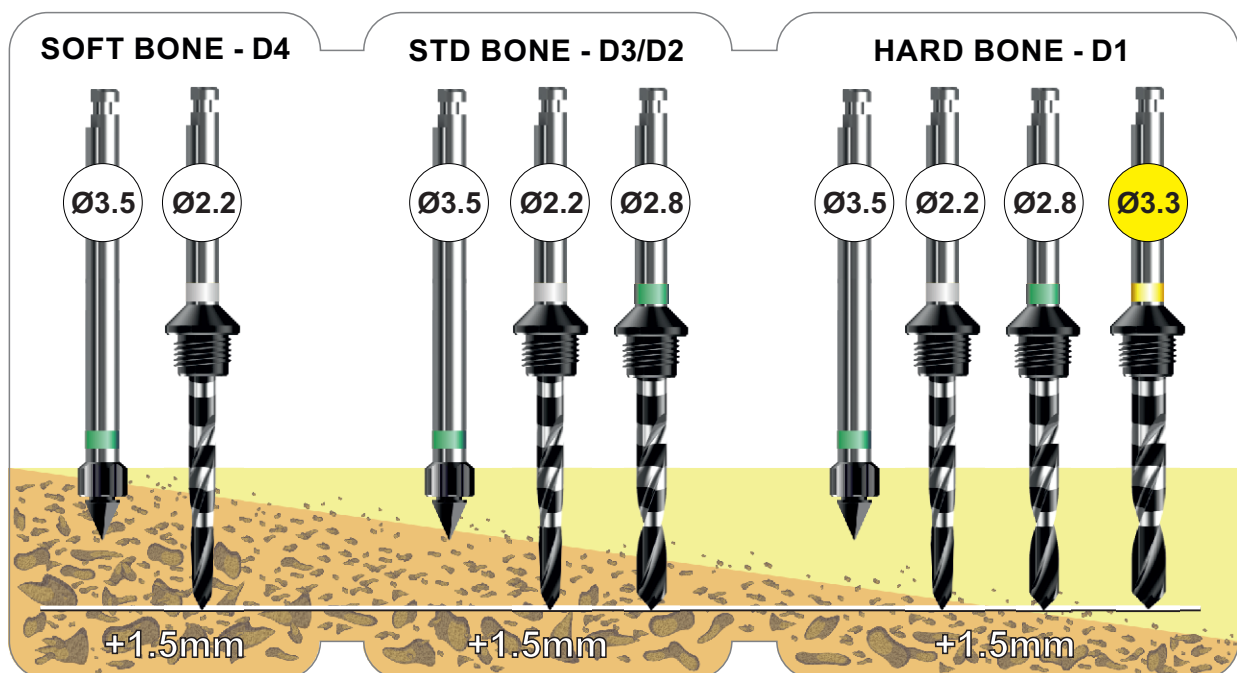

TAPERED SHAPE MOUNTERLESS

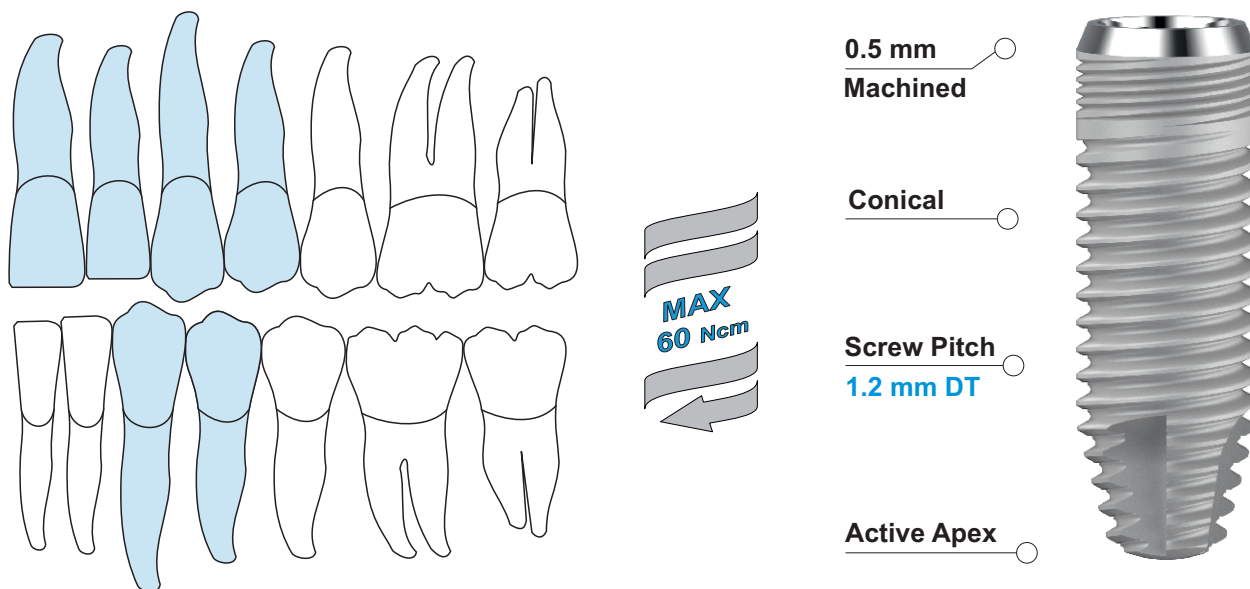

CODE	IMPLANT	LENGTH	PLATFORM	APEX
IC 4085	Ø 3.8	8.5 mm	Ø 4.0	Ø 2.9
IC 4010	Ø 3.8	10 mm	Ø 4.0	Ø 2.9
IC 4012	Ø 3.8	12 mm	Ø 4.0	Ø 2.9
IC 4013	Ø 3.8	13.5 mm	Ø 4.0	Ø 2.9

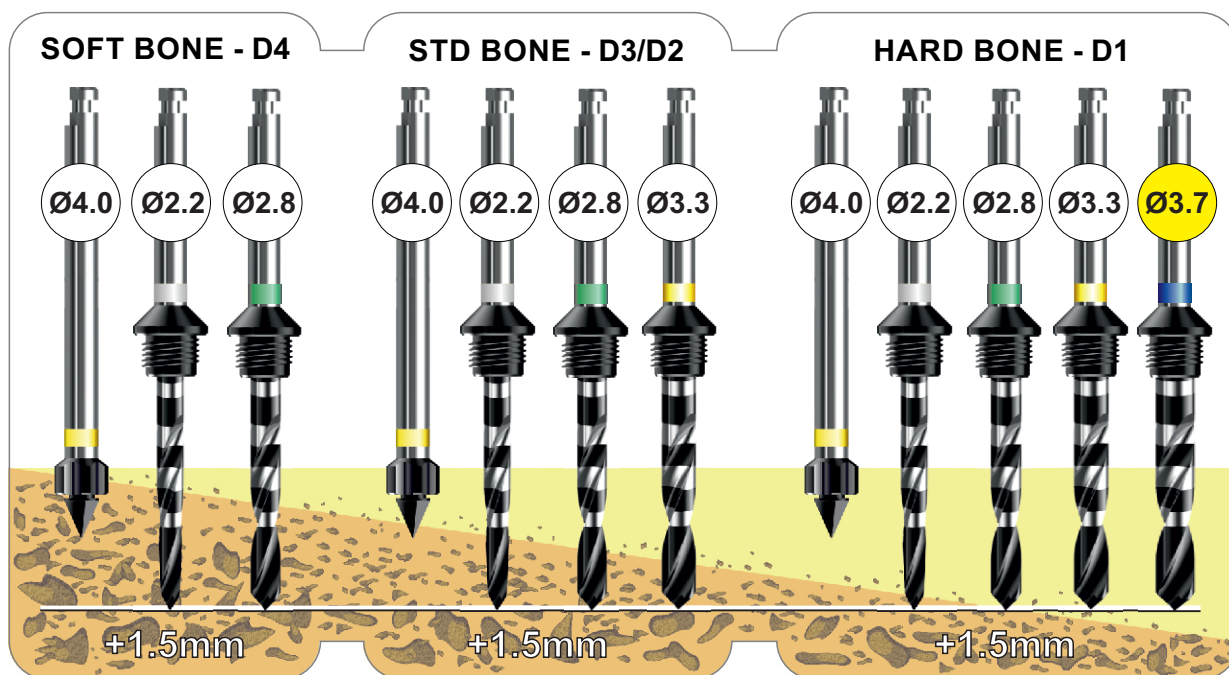

TAPERED SHAPE MOUNTERLESS

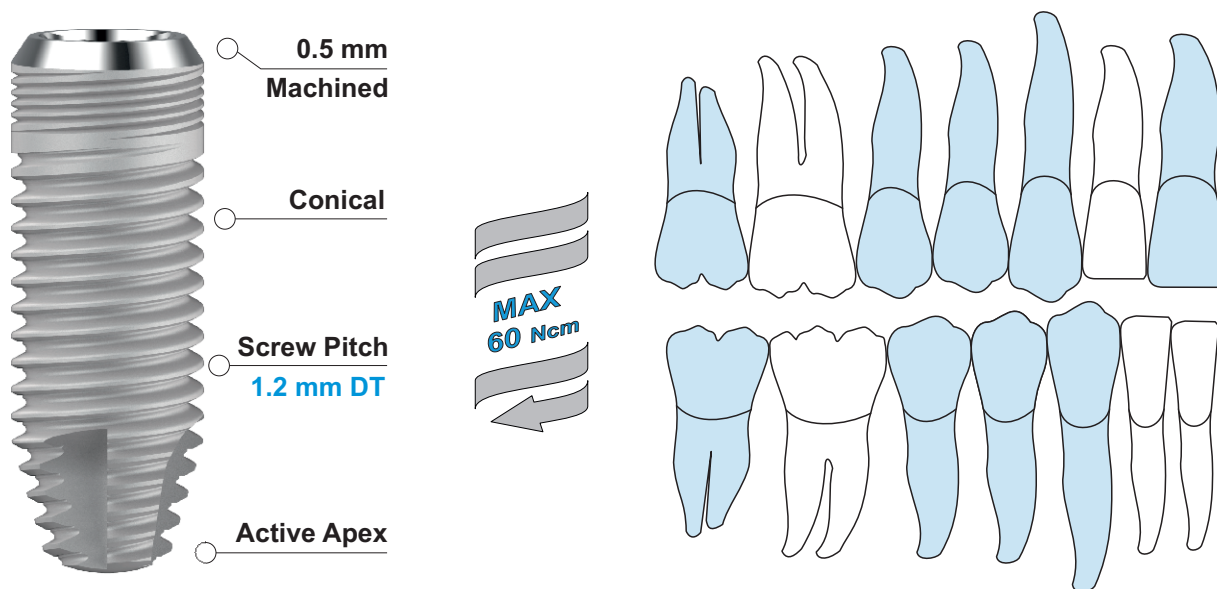

CODE	IMPLANT	LENGTH	PLATFORM	APEX
IC 4585	Ø 4.3	8.5 mm	Ø 4.5	Ø 3.4
IC 4510	Ø 4.3	10 mm	Ø 4.5	Ø 3.4
IC 4512	Ø 4.3	12 mm	Ø 4.5	Ø 3.4
IC 4513	Ø 4.3	13.5 mm	Ø 4.5	Ø 3.4

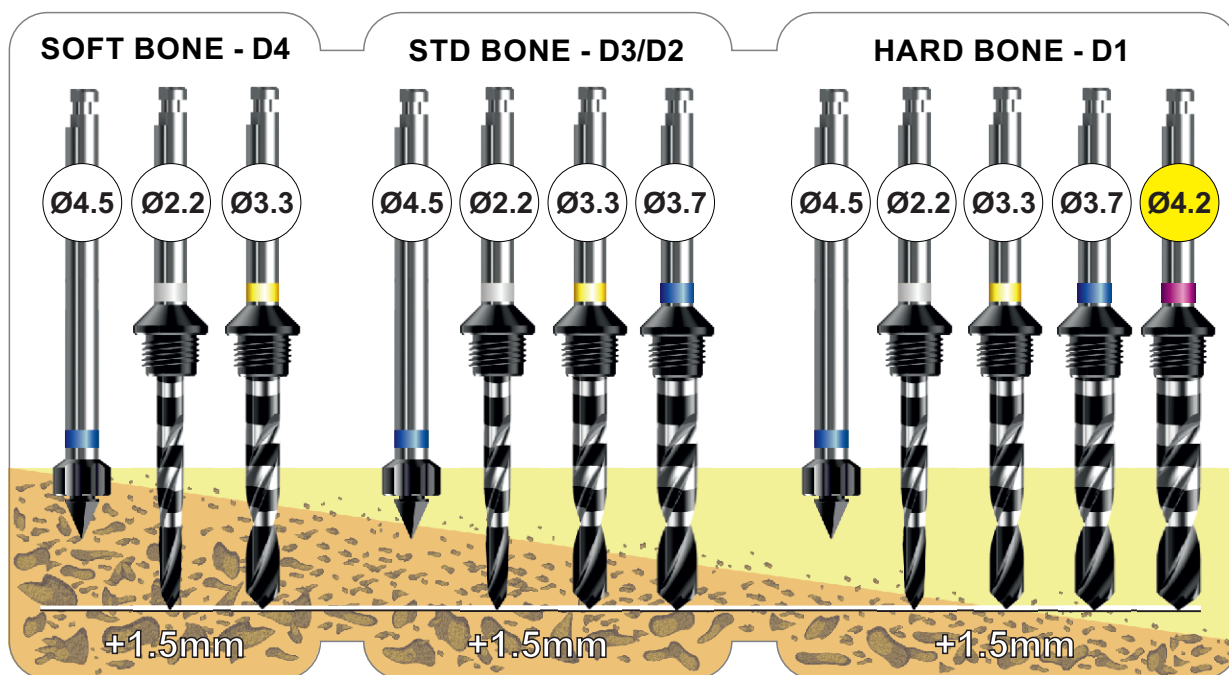

TAPERED SHAPE MOUNTERLESS

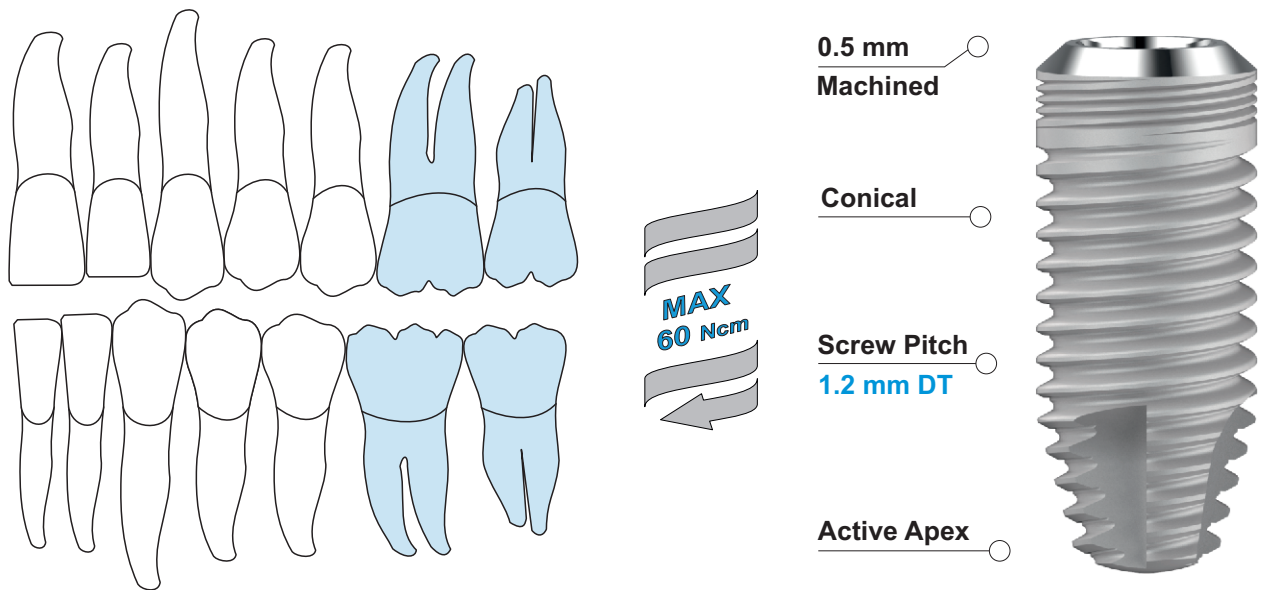

CODE	IMPLANT	LENGTH	PLATFORM	APEX
IC 5085	Ø 4.8	8.5 mm	Ø 5.0	Ø 3.9
IC 5010	Ø 4.8	10 mm	Ø 5.0	Ø 3.9
IC 5012	Ø 4.8	12 mm	Ø 5.0	Ø 3.9
IC 5013	Ø 4.8	13.5 mm	Ø 5.0	Ø 3.9

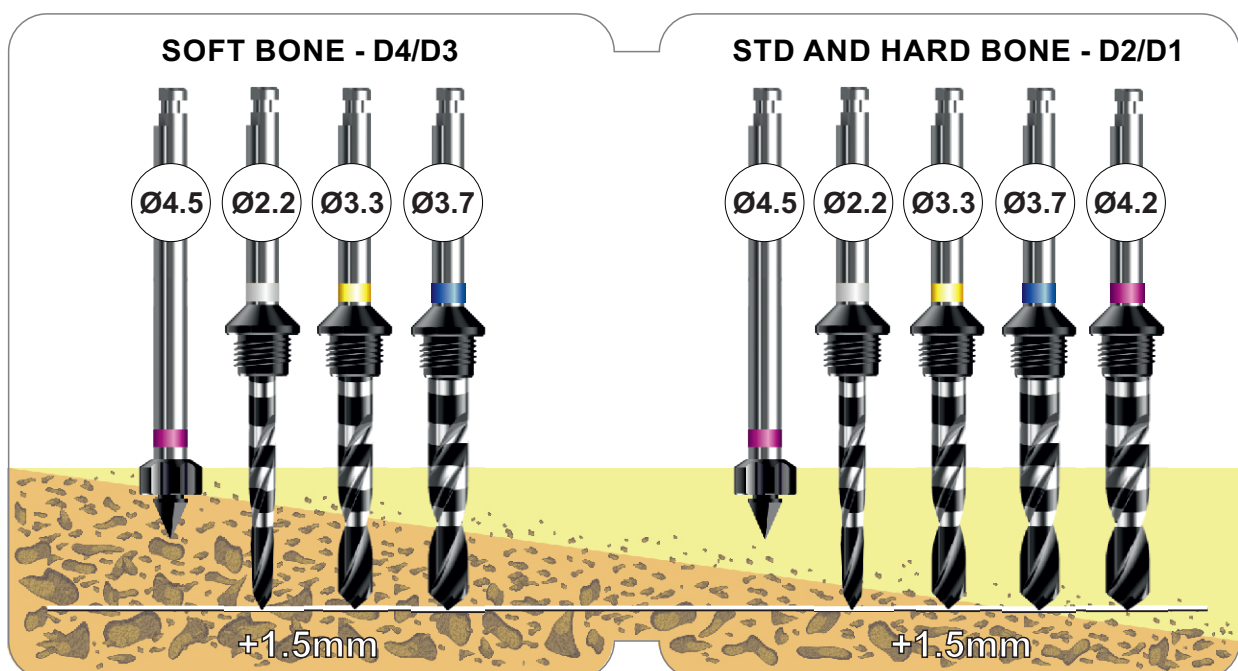



MORSE CONICAL CONNECTION UNIVERSAL CONNECTION

UNIVERSAL PROSTHETICS



20Ncm 



Pilastro di Guarigione STANDARD - Titanio Gr. 5

STANDARD Healing Abutment - Titanium Gr. 5

VI 3000 H 3 mm - Standard Gingival Profile Ø 4.5

VI 5000 H 5 mm - Standard Gingival Profile Ø 4.5

VI 7000 H 7 mm - Standard Gingival Profile Ø 4.5

DMRP120S Standard Hexagonal Driver Ø 1.20

20Ncm 

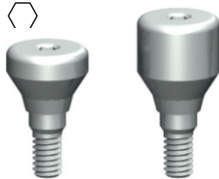

Pilastro di Guarigione ANATOMICO - Titanio Gr. 5

ANATOMICAL Healing Abutment - Titanium Gr. 5

VI 30SV H 3 mm - Anatomical Gingival Profile Ø 5.0

VI 50SV H 5 mm - Anatomical Gingival Profile Ø 5.0

DMRP120S Standard Hexagonal Driver Ø 1.20

20Ncm 



Pilastro di Guarigione Largo ANATOMICO - Titanio Gr. 5

ANATOMICAL Large Healing Abutment - Titanium Gr. 5

VI 6030 H 3 mm - Anatomical Large Gingival Profile Ø 6.0

VI 6050 H 5 mm - Anatomical Large Gingival Profile Ø 6.0

DMRP120S Standard Hexagonal Driver Ø 1.20



Analogo per Laboratorio - Titanio Gr. 5 - Anodizzato

Laboratory Analog - Titanium Gr. 5 - Anodized

AN 1000 H 12 mm - Universal Shape

 15Ncm

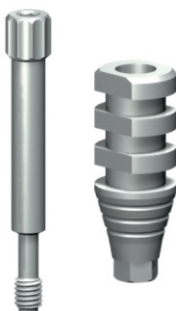

Transfer per impronta Pick Up - Titanio Gr. 5

Pick Up Impression Coping - Titanium Gr. 5

TR 1000 Antirotaion Hex

VITR00 Vite Lunga di Ricambio - Long Spare Screw

DMRP120S Standard Hexagonal Driver Ø 1.20

universal prosthetics

Transfer per Impronta a Strappo Cucchiaino Chiuso - Titanio Gr. 5

Closed Tray Impression Coping - Titanium Gr. 5

TR 1100 Antirotation Hex

TRS 1100 Snap-On

VIPA00 Vite di Ricambio - Spare Screw

DMRP120S Standard Hexagonal Driver Ø 1.20

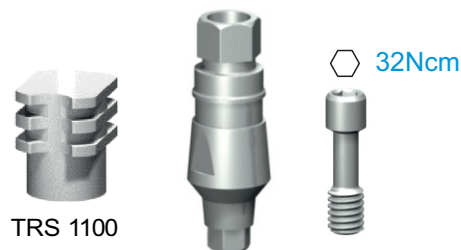

Pilastro Temporaneo da Incollaggio - Titanio Gr. 5

Temporary Glueing Abutment - Titanium Gr. 5

MOFL 00 Temporary Glueing - Rotating - Gingival Profile H1mm

VPF00 Vite di Ricambio - Spare Screw

DMRP120S Standard Hexagonal Driver Ø 1.20



Moncone Titanio Diritto - Titanio Gr. 5

Straight Titanium Abutment - Titanium Gr. 5

MDN 1000 Straight - Antirotation Hex - Narrow Gingival Profile H1.5mm

VIPA00 Vite di Ricambio - Spare Screw

DMRP120S Standard Hexagonal Driver Ø 1.20



Moncone Titanio Diritto - Titanio Gr. 5

Straight Titanium Abutment - Titanium Gr. 5

MD 1000 Straight - Antirotation Hex - Standard Gingival Profile H2mm

MD 1040 Straight - Antirotation Hex - Standard Gingival Profile H4mm

MD 1050 Straight - Antirotation Hex - Standard Gingival Profile H5mm

VIPA00 Vite di Ricambio - Spare Screw

DMRP120S Standard Hexagonal Driver Ø 1.20



Moncone Titanio Diritto - Titanio Gr. 5

Straight Titanium Abutment - Titanium Gr. 5

MA 1000 Straight - Antirotation Hex - Standard Gingival Profile H2mm

MA 1040 Straight - Antirotation Hex - Standard Gingival Profile H4mm

VIPA00 Vite di Ricambio - Spare Screw

DMRP120S Standard Hexagonal Driver Ø 1.20



32Ncm

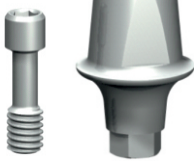

Moncone Titanio Dritto Spallato - Titanio Gr. 5

Shoulder Straight Titanium Abutment - Titanium Gr. 5

MD 6020 H 2 mm - Large Gingival Profile Ø 6.0

MD 6040 H 4 mm - Large Gingival Profile Ø 6.0

VIPA00 Vite di Ricambio - Spare Screw

DMRP120S Standard Hexagonal Driver Ø 1.20

32Ncm

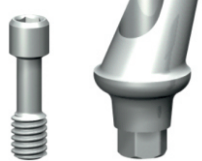

Moncone Titanio Angolato 15° - Titanio Gr. 5

15° Angled Titanium Abutment - Titanium Gr. 5

MA 1500 H 2 mm - Standard Gingival Profile Ø 5.0

MA 1540 H 4 mm - Standard Gingival Profile Ø 5.0

VIPA00 Vite di Ricambio - Spare Screw

DMRP120S Standard Hexagonal Driver Ø 1.20

32Ncm

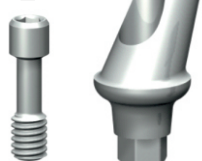

Moncone Titanio Angolato 25° - Titanio Gr. 5

25° Angled Titanium Abutment - Titanium Gr. 5

MA 2500 H 2 mm - Standard Gingival Profile Ø 5.0

MA 2540 H 4 mm - Standard Gingival Profile Ø 5.0

VIPA00 Vite di Ricambio - Spare Screw

DMRP120S Standard Hexagonal Driver Ø 1.20

32Ncm

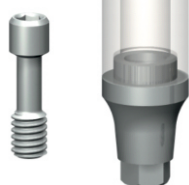

Link in Titanio con Calcinabile - Titanio Gr. 5

Titanium Link with Castable Abutment - Titanium Gr. 5

CA 10TI Antirotaion Hex - Standard Gingival Profile H3mm

VIPA00 Vite di Ricambio - Spare Screw

DMRP120S Standard Hexagonal Driver Ø 1.20

32Ncm

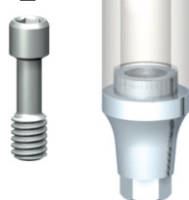

Moncone UCLA Cobalto Cromo - CoCr

UCLA Abutment Cobalt Chrome - CoCr

CA 10CR Antirotaion Hex - Standard Gingival Profile H3mm

CR 10CR Rotating - Standard Gingival Profile H3mm

CAS 10CR Antirotaion Hex - Standard Gingival Profile H2mm

VIPA00 Vite di Ricambio - Spare Screw

DMRP120S Standard Hexagonal Driver Ø 1.20

universal prosthetics

Moncone Calcinabile - Acrilico

Castable Abutment - Acrylic

CA 1000 Antirotation Hex - Standard Gingival Profile H2mm

CR 1000 Rotating - Standard Gingival Profile H2mm

VIPA00 Vite di Ricambio - Spare Screw

DMRP120S Standard Hexagonal Driver Ø 1.20

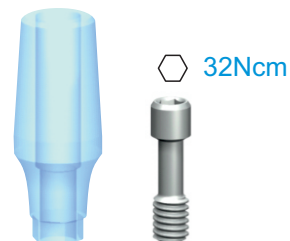

Pilastrì a Sfera per Overdenture - Titanio Gr. 5

Overdenture Ball Abutments - Titanium Gr. 5

MO 0001 Normo - Standard Gingival Profile H1mm

MO 0003 Normo - Standard Gingival Profile H3mm

MO 0005 Normo - Standard Gingival Profile H5mm

DMRP120S Standard Hexagonal Driver Ø 1.20



Cappette Ritentive Normo - Teflon

Normo Retentive Caps - Teflon

TF 10 Bianca - White 1300 gr

TF 08 Rosa - Pink 800 gr

TF 06 Gialla - Yellow 600 gr

TF 04 Verde - Green 400 gr



Contenitore Metallico per Cappette Ritentive Normo

Normo Retentive Caps Metal Box

CO 01 Stainless Steel Metal Box

CO 02 Titanium Metal Box



Kit Pilastro Equator per Overdenture - Titanio Gr. 5 - PVD TiN

Overdenture Equator Abutment Kit - Titanium Gr. 5 - PVD TiN

BPEQ1 H 1 mm - Narrow Gingival Profile

BPEQ2 H 2 mm - Narrow Gingival Profile

BPEQ3 H 3 mm - Narrow Gingival Profile

BPEQ4 H 4 mm - Narrow Gingival Profile

BPEQ5 H 5 mm - Narrow Gingival Profile



OT Equator - accessories and spare parts



Cappette OT Equator

OT Equator Caps

TFQ 1	Strong Retention
TFQ 2	Standard Retention
TFQ 3	Soft Retention
TFQ 4	Extra Soft Retention
TFQ 5	Dental Laboratory Cap

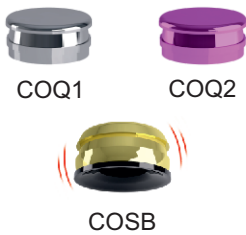

Contentori OT Equator

OT Equator Metal Box

COQ 1	Stainless Steel Metal Box
COQ 2	Titanium Metal Box
COSB	Smart Box



Kit ricambi OT Equator

OT Equator Spare parts Kits

NBOXEQ	Standard Spare parts Kit
SBOXEQ	Smart Box Spare parts Kit



Link Base per Incollaggio Rotante - Titanio Gr. 5

Rotating Bonding Technique Base Link - Titanium Gr. 5

ALEQ	Analog
TISEQ	Transfer
F20EQ	Equator Screw
SCEQ	Castable Equator
TFSB	Smart Box Transfer Black



Strumenti Equator

Equator Tools

IEQ	Inserter - Extractor
DMEQ	Manual Driver
DCEQ	Contra-angle Driver

Overdenture Loc Abutment

Kit LOC Abutment - Pilastro + Contenitore Metallico + Cappette

LOC Abutment Kit - Abutment + Metal Box + Caps

- BPLC1** Kit LOC Abutment H1 mm - Ø4.0
- BPLC2** Kit LOC Abutment H2 mm - Ø4.0
- BPLC3** Kit LOC Abutment H3 mm - Ø4.0
- BPLC4** Kit LOC Abutment H4 mm - Ø4.0
- BPLC5** Kit LOC Abutment H5 mm - Ø4.0

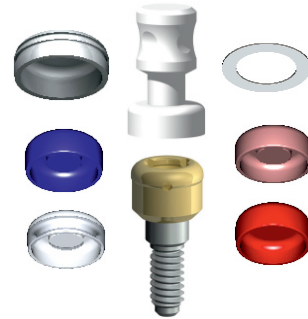

Accessori e Ricambi LOC Abutment

LOC Abutment Accessories and Spare Parts

- TSLC** Transfer Ti + Cappetta Nera (per laboratorio)
- COLC1** Contenitore Ti + Cappetta Nera (per laboratorio)
- NBOXLC** Kit Cappette + Contenitore Ti
- TFLC50** Cappetta Ritentiva Trasparente - 2268 g 4 pz.
- TFLC30** Cappetta Ritentiva Rosa - 1361 g 4 pz.
- TFLC15** Cappetta Ritentiva Blu - 680 g 4 pz.
- ALLC** Analogo in Titanio
- TFLCD40** Cappetta Ritentiva Verde - 1814 g 4 pz.
- TFLCD20** Cappetta ritentiva Arancione - 907 g 4 pz.
- TFLCD15** Cappetta ritentiva Rossa - 680 g 4 pz.
- DMLC** Avvitatore da Cricchetto (attacco Straumann®)
- DCLC** Avvitatore da Contrangolo
- IELC** Inseritore / Estrattore Cappette

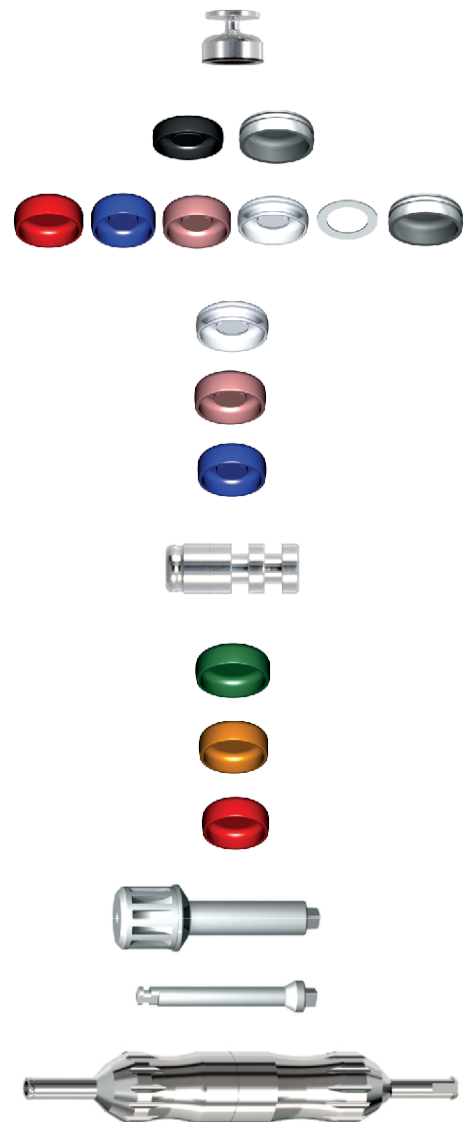

32Ncm

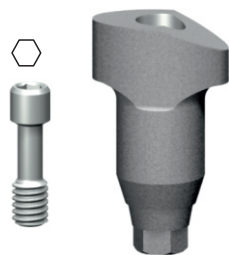

Transfer per impronta Digitale - Titanio Gr. 5

Scan Abutment - Titanium Gr. 5

SCA 00 Standard Gingival Profile Ø 4.5

VIPA00 Vite di Ricambio - Spare Screw

DMRP120S Standard Hexagonal Driver Ø 1.20

Analogo CAD da Laboratorio con Vite - Titanio Gr. 5

Laboratory CAD Analog with Screw - Titanium Gr. 5

AN3D 00 Con vite ritentiva per modelli stampati

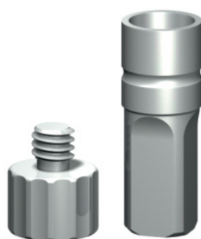

Link Base per Incollaggio Antirotazione - Titanio Gr. 5

Antirotation Bonding Technique Base Link - Titanium Gr. 5

32Ncm

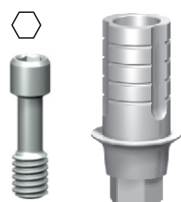

LK 1001 Gingival Profile **H 1mm** - Antirotation Hex

LK 1002 Gingival Profile **H 2mm** - Antirotation Hex

LK 1003 Gingival Profile **H 3mm** - Antirotation Hex

VIPA00 Vite di Ricambio - Spare Screw

DMRP120S Standard Hexagonal Driver Ø 1.20

Link Base per Incollaggio Rotante - Titanio Gr. 5

Rotating Bonding Technique Base Link - Titanium Gr. 5

32Ncm



LKR 1001 Gingival Profile **H 1mm** - Rotating

LKR 1002 Gingival Profile **H 2mm** - Rotating

LKR 1003 Gingival Profile **H 3mm** - Rotating

VIPA00 Vite di Ricambio - Spare Screw

DMRP120S Standard Hexagonal Driver Ø 1.20

20Ncm

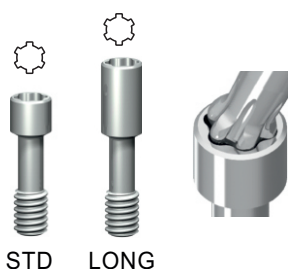

Viti protesiche per canale angolato - Titanio Gr. 5

Prosthetic screws for angled hole - Titanio Gr. 5

VIPA 00AI Vite Standard per canale angolato - STANDARD

VIPA 00AITL Vite Lunga + 2mm per canale angolato - LONG

MDT6DS Manual Torque Driver for angled hole

DCT6DS RA Contr-angle Torque Driver for angled hole

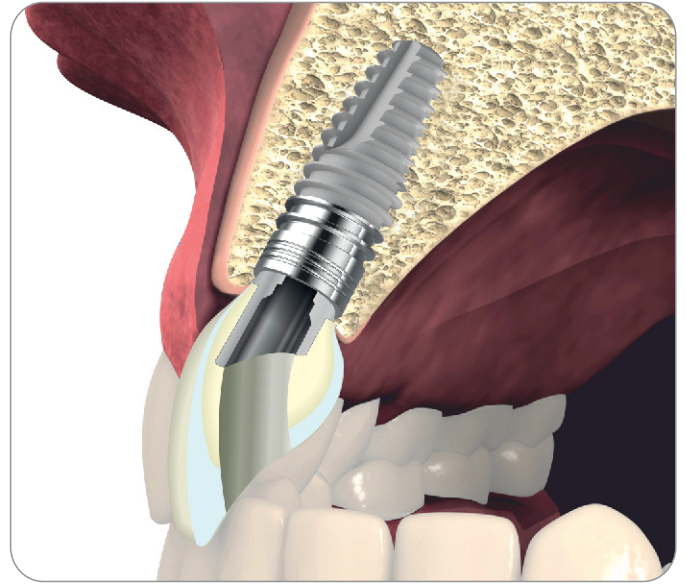
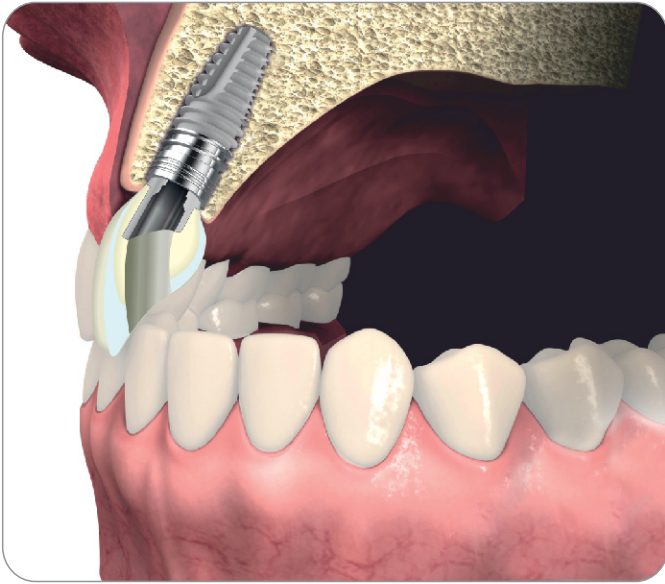

GESTIONE DEL PASSAGGIO VITE INCLINATO IN PROTESI AVVITATA

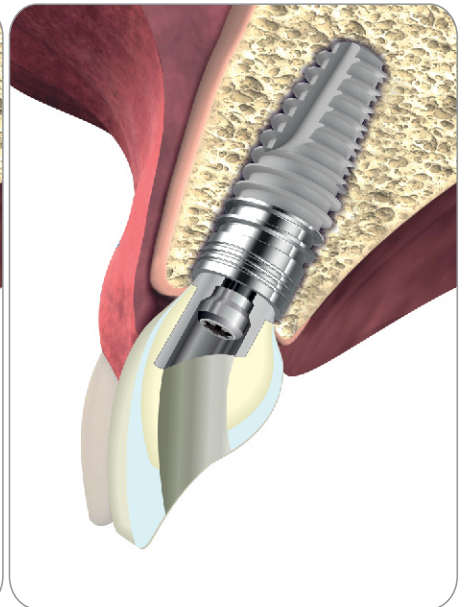
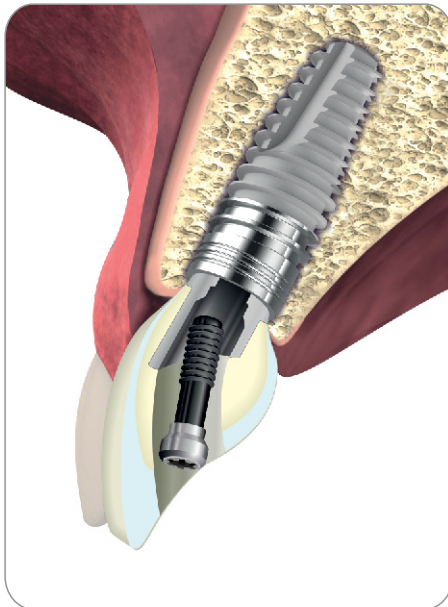
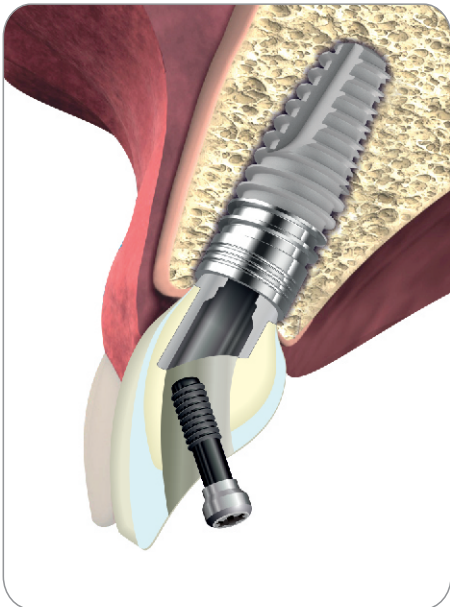

AVVITAMENTO ANGOLATO CON T6 ANGLED TORX DRIVER



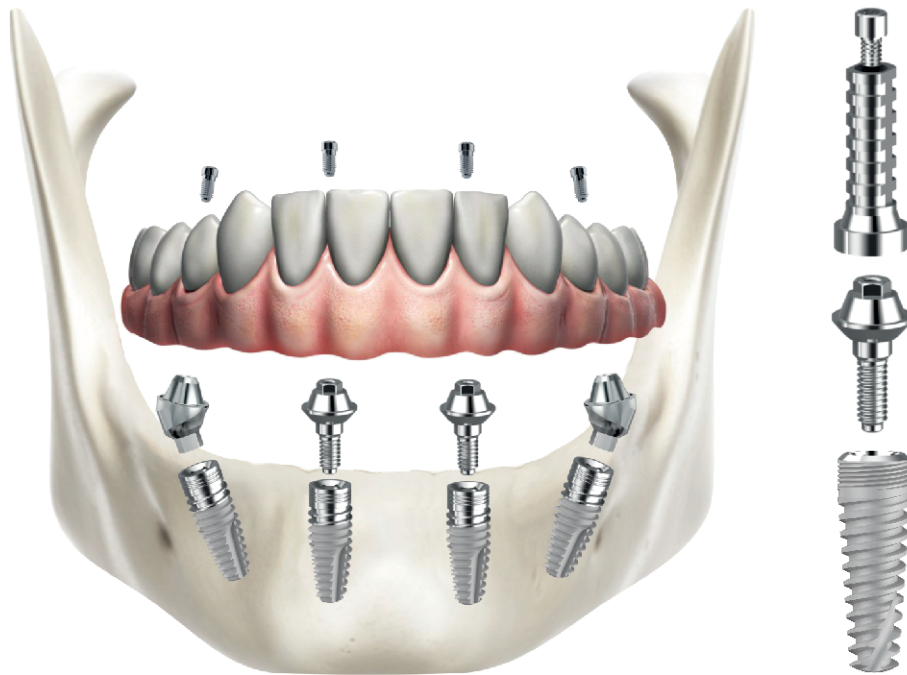

Pilastro Toronto Dritto - Titanio Gr. 5

Toronto Straight Abutment - Titanium Gr. 5

- MU 0001** Toronto Straight MUA Abutment H1
- MU 0002** Toronto Straight MUA Abutment H2
- MU 0003** Toronto Straight MUA Abutment H3
- MU 0004** Toronto Straight MUA Abutment H4

DCDM Toronto Straight Abutment Driver

32Ncm 

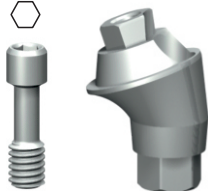

Pilastro Toronto Angolato 17° - Titanio Gr. 5

17° Toronto Angled Abutment - Titanium Gr. 5

- MU 1700** Toronto Angled 17° MUA Abutment H3
- MU 1750** Toronto Angled 17° MUA Abutment H5

VIPA00 Vite di Ricambio - Spare Screw

DMRP120S Standard Hexagonal Driver Ø 1.20

32Ncm 

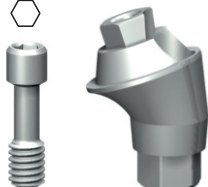

Pilastro Toronto Angolato 30° e 45° - Titanio Gr. 5

30° and 45° Toronto Angled Abutment - Titanium Gr. 5

- MU 3000** Toronto Angled 30° MUA Abutment H3
- MU 3050** Toronto Angled 30° MUA Abutment H5
- MU 4500** Toronto Angled 45° MUA Abutment H4.5

VIPA00 Vite di Ricambio - Spare Screw

DMRP120S Standard Hexagonal Driver Ø 1.20

Pilastro Temporaneo Toronto Rotante - Titanio Gr. 5
Rotating Toronto Temporary Abutment - Titanium Gr. 5

TT 1000 Rotating Temporary

VIPMU 00 Vite di Ricambio - Spare Screw
DMRP120S Standard Hexagonal Driver Ø 1.20

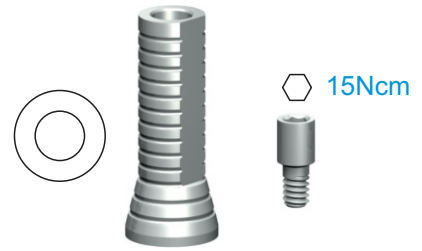

Pilastro Temporaneo Toronto Antirotazione - Titanio Gr. 5
Antirotation Hex Toronto Temporary Abutment - Titanium Gr. 5

TTA 1000 Antirotation Hex Temporary

VIPMU 00 Vite di Ricambio - Spare Screw
DMRP120S Standard Hexagonal Driver Ø 1.20

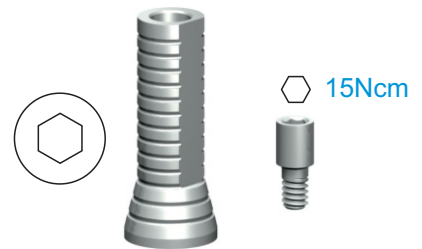

Pilastro Toronto Calcinabile Rotante
Rotating Castable Toronto Abutment

TC 1000 Toronto Castable Abutment - Rotating

VIPMU 00 Vite di Ricambio - Spare Screw
DMRP120S Standard Hexagonal Driver Ø 1.20

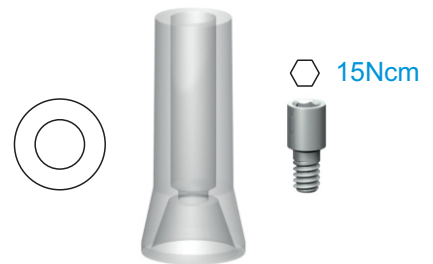

Pilastro Toronto Calcinabile Antirotazione
Antirotation Hex Castable Toronto Abutment

TCA 1000 Toronto Castable Abutment - Antirotation Hex

VIPMU 00 Vite di Ricambio - Spare Screw
DMRP120S Standard Hexagonal Driver Ø 1.20

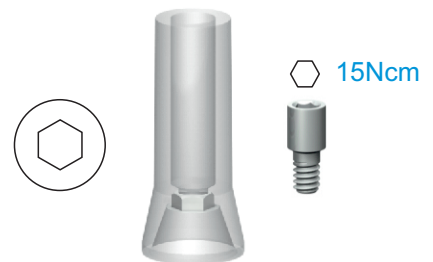

Pilastro Toronto in Cromo Cobalto
CoCr Toronto Abutment

TTCR 1000 Toronto CoCr Abutment - Rotating

VIPMU 00 Vite di Ricambio - Spare Screw
DMRP120S Standard Hexagonal Driver Ø 1.20

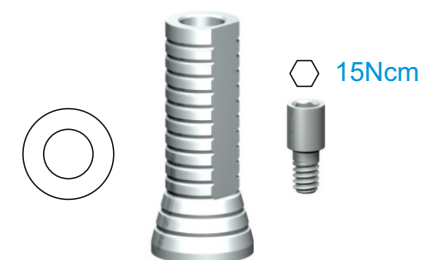



Analogo Toronto per Laboratorio Rotante - Titanio Gr. 5
Rotating Laboratory Toronto Analog - Titanium Gr. 5

MA 1000 Rotating Toronto Analog

VIPA00 Vite di Ricambio - Spare Screw

DMRP120S Standard Hexagonal Driver Ø 1.20



Analogo Toronto per Laboratorio Antirotazione - Titanio Gr. 5
Antirootation Hex Laboratory Toronto Analog - Titanium Gr. 5

MA 1040 Antirootation Hex Toronto Analog

VIPA00 Vite di Ricambio - Spare Screw

DMRP120S Standard Hexagonal Driver Ø 1.20

15Ncm

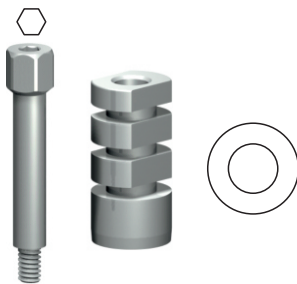

Transfer Toronto Rotante - Titanio Gr. 5
Rotating Toronto Impression Coping - Titanium Gr. 5

MU 10TR Rotating Toronto Impression Coping

VIPMUTR Vite lunga di Ricambio - Long Spare Screw

DMRP120S Standard Hexagonal Driver Ø 1.20

15Ncm

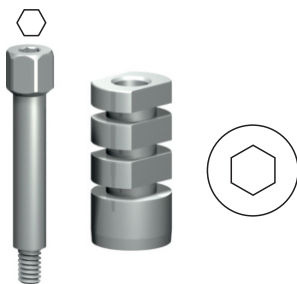

Transfer Toronto Antirotazione - Titanio Gr. 5
Antirootation Hex Toronto Impression Coping - Titanium Gr. 5

MU 10TRA Antirootation Hex Toronto Impression Coping

VIPMUTR Vite lunga di Ricambio - Long Spare Screw

DMRP120S Standard Hexagonal Driver Ø 1.20

15Ncm



Pilastro di Guarigione Toronto
Toronto Healing Abutment

MU 10VI Toronto Healing Abutment H4.5mm

DMRP120S Standard Hexagonal Driver Ø 1.20

Transfer per impronta Digitale - Titanio Gr. 5
Scan Abutment - Titanium Gr. 5
SCA 00 Standard Gingival Profile Ø 4.5

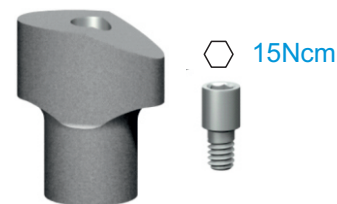
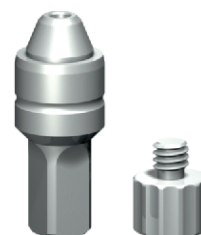
VIPA00 Vite di Ricambio - Spare Screw
DMRP120S Standard Hexagonal Driver Ø 1.20

Analogo CAD da Laboratorio con Vite - Titanio Gr. 5
Laboratory CAD Analog with Screw - Titanium Gr. 5
AN3D 00 Con vite ritentiva per modelli stampati

Link Base per Incollaggio Antirotazione - Titanio Gr. 5
Antirotation Bonding Technique Base Link - Titanium Gr. 5
LK 1001 Gingival Profile H 1mm - Antirotation Hex

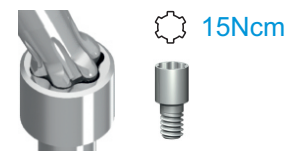
VIPA00 Vite di Ricambio - Spare Screw
DMRP120S Standard Hexagonal Driver Ø 1.20

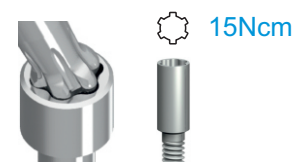
Vite protesica Toronto per canale angolato - Titanio Gr. 5
Prosthetic screw for angled hole - Titanium Gr. 5
VPMU 00AI Vite Standard per canale angolato - STANDARD

MDT6DS Manual Torque Driver for angled hole
DCT6DS RA Contr-angle Torque Driver for angled hole

Vite protesica Toronto per canale angolato - Titanio Gr. 5
Prosthetic screw for angled hole - Titanium Gr. 5
VPMU 00AITL Vite Lunga + 2mm per canale angolato - LONG

MDT6DS Manual Torque Driver for angled hole
DCT6DS RA Contr-angle Torque Driver for angled hole

oneabutment octa prosthetics



Oneabutment Octa 3.8 - Titanio Gr. 5

Oneabutment Octa 3.8 - Titanium Gr. 5

IPBO 381	Oneabutment Transgengivale H1 mm Cono Morse
IPBO 382	Oneabutment Transgengivale H2 mm Cono Morse
IPBO 383	Oneabutment Transgengivale H3 mm Cono Morse
IPBO 384	Oneabutment Transgengivale H4 mm Cono Morse
IPBO 385	Oneabutment Transgengivale H5 mm Cono Morse

DCOCT1

[Prolunga da Cricchetto Corta per serraggio Octa](#)



Oneabutment Octa 4.8 - Titanio Gr. 5

Oneabutment Octa 4.8 - Titanium Gr. 5

IPBO 481	Oneabutment Transgengivale H1 mm Cono Morse
IPBO 482	Oneabutment Transgengivale H2 mm Cono Morse
IPBO 483	Oneabutment Transgengivale H3 mm Cono Morse
IPBO 484	Oneabutment Transgengivale H4 mm Cono Morse
IPBO 485	Oneabutment Transgengivale H5 mm Cono Morse

DCOCT1

[Prolunga da Cricchetto Corta per serraggio Octa](#)

15Ncm 



Pilastro di Guarigione Octa - Titanio Gr. 5

Octa Healing Abutment - Titanium Gr. 5

EPHAO 384	Healing Cap Octa Ø 3.8 mm
EPHAO 484	Healing Cap Octa Ø 4.8 mm

25Ncm 

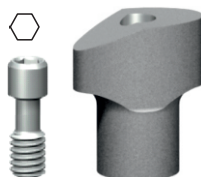

Transfer per impronta Digitale - Titanio Gr. 5

Scan Abutment - Titanium Gr. 5

EPSA038	Scan Abutment Octa Ø 3.8 mm
EPSA048	Scan Abutment Octa Ø 4.8 mm

EPVO

Vite di Ricambio - Spare Screw

DMRP120S

[Standard Hexagonal Driver Ø 1.20](#)

15Ncm

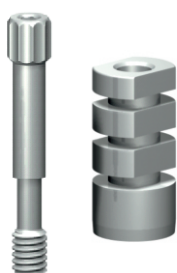

Transfer per impronta Pick Up - Titanio Gr. 5

Pick Up Impression Coping - Titanium Gr. 5

EPIAO38DS	Impression Coping Octa Ø 3.8 mm
EPIAO48DS	Impression Coping Octa Ø 4.8 mm

DMRP120S

[Standard Hexagonal Driver Ø 1.20](#)

oneabutment octa prosthetics

Analogo Digitale Octa per Laboratorio - Titanio Gr. 5

Laboratory Octa Digital Analog - Titanium Gr. 5

EPBALO38DS Analogo Digitale Octa Ø 3.8 mm

EPBALO48DS Analogo Digitale Octa Ø 4.8 mm

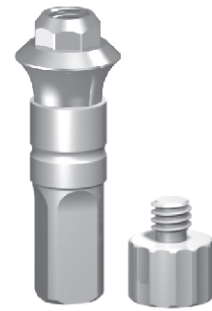

Pilastro Temporaneo Octa Rotante - Titanio Gr. 5

Rotating Octa Temporary Abutment - Titanium Gr. 5

EPTRO38 Rotating Temporary Octa Ø 3.8 mm

EPTRO48 Rotating Temporary Octa Ø 4.8 mm

EPVO Vite di Ricambio - Spare Screw

DMRP120S Standard Hexagonal Driver Ø 1.20

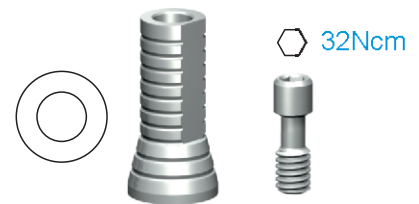

Pilastro Temporaneo Octa Antirotazione - Titanio Gr. 5

Antirotation Hex Octa Temporary Abutment - Titanium Gr. 5

EPTAO38 Antirotation Hex Temporary Octa Ø 3.8 mm

EPTAO48 Antirotation Hex Temporary Octa Ø 4.8 mm

EPVO Vite di Ricambio - Spare Screw

DMRP120S Standard Hexagonal Driver Ø 1.20

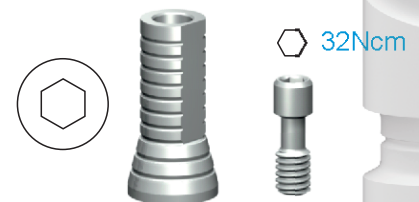

Link Base Octa per Incollaggio Rotante - Titanio Gr. 5

Rotating Bonding Technique Octa Base Link - Titanium Gr. 5

EPTRO38DS Rotating TiBase Octa Ø 3.8 mm

EPTRO48DS Rotating TiBase Octa Ø 4.8 mm

EPVO Vite di Ricambio - Spare Screw

EPVLOT6DS Vite per Canale Angolato - Angled Hole Screw

DMRP120S Standard Hexagonal Driver Ø 1.20

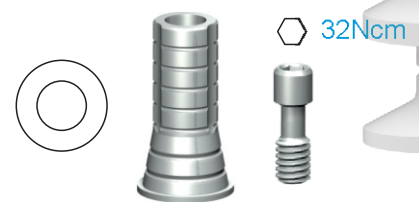

Link Base Octa per Incollaggio Antirotazione - Titanio Gr. 5

Antirotation Bonding Technique Octa Base Link - Titanium Gr. 5

EPTAO38DS Antirotation Hex TiBase Octa Ø 3.8 mm

EPTAO48DS Antirotation Hex TiBase Octa Ø 4.8 mm

EPVO Vite di Ricambio - Spare Screw

EPVLOT6DS Vite per Canale Angolato - Angled Hole Screw

DMRP120S Standard Hexagonal Driver Ø 1.20

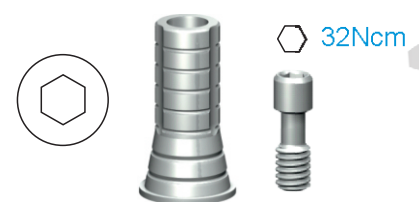

cone abutment prosthetics

32Ncm

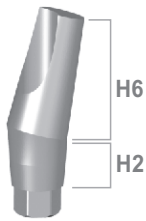

Moncone CONE Angolato - Titanio Gr. 5

Angled CONE Abutment - Titanium Gr. 5

IPBCON 7L2 7.5° Angled CONE Abutment H2 mm **Long 6 mm**

IPBCON 15L2 15° Angled CONE Abutment H2 mm **Long 6 mm**

VIPA00 Vite di Ricambio - Spare Screw

DMRP120S Standard Hexagonal Driver Ø 1.20

32Ncm

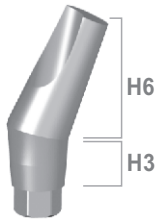

Moncone CONE Angolato - Titanio Gr. 5

Angled CONE Abutment - Titanium Gr. 5

IPBCON 22L3 22.5° Angled CONE Abutment H3 mm **Long 6 mm**

IPBCON 30L3 30° Angled CONE Abutment H3 mm **Long 6 mm**

VIPA00 Vite di Ricambio - Spare Screw

DMRP120S Standard Hexagonal Driver Ø 1.20

32Ncm

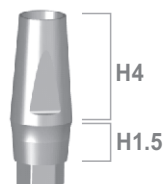

Moncone CONE Diritto Basso 4mm - Titanio Gr. 5

CONE Straight Low Abutment 4mm - Titanium Gr. 5

IPBCON 0S1 Straight CONE Abutment H1.5 mm **Short 4 mm**

VIPA00 Vite di Ricambio - Spare Screw

DMRP120S Standard Hexagonal Driver Ø 1.20

32Ncm

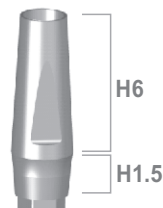

Moncone CONE Diritto Alto 6mm - Titanio Gr. 5

CONE Straight High Abutment 6mm - Titanium Gr. 5

IPBCON 0S1 Straight CONE Abutment H1.5 mm **Long 6 mm**

VIPA00 Vite di Ricambio - Spare Screw

DMRP120S Standard Hexagonal Driver Ø 1.20



Cappetta CONE da Saldatura - Titanio Gr. 5

CONE Welding Cap - Titanium Gr. 5

CTCON RS-S CONE Welding Cap **Short 4 mm** - Rotating

CTCON RL-S CONE Welding Cap **Long 6 mm** - Rotating

cone abutment prosthetics

Cappetta CONE da Incollaggio H4mm - Titanio Gr. 5

CONE Gluing Cap H4mm - Titanium Gr. 5

CTCON RS CONE Gluing Cap **Short 4 mm** - Rotating

CTCON AS CONE Gluing Cap **Short 4 mm** - Anti-rotation



H4

Cappetta CONE da Incollaggio H4mm - Titanio Gr. 5

CONE Gluing Cap H4mm - Titanium Gr. 5

CTCON RL CONE Gluing Cap **Long 6 mm** - Rotating

CTCON AL CONE Gluing Cap **Long 6 mm** - Anti-rotation



H6

Transfer CONE Digitale e Cappetta CONE - PEEK

Scan Abutment and CONE Cap - PEEK

IACON S Scan Abutment/Peek Cap CONE **Short 4 mm**

IACON L Scan Abutment/Peek Cap CONE **Long 6 mm**



Analogo Digitale CONE per Laboratorio - Titanio Gr. 5

Laboratory CONE Digital Analog - Titanium Gr. 5

ALCON S Digital Analog CONE **Short 4 mm**

ALCON L Digital Analog CONE **Long 6 mm**

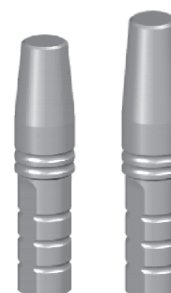

H4

H6

Parallelizzatore Intraorale Manuale CONE - Titanio Gr. 5

CONE Intraoral Manual Parallelizer - Titanium Gr. 5

PARCON Intraoral Manual Parallelizer CONE

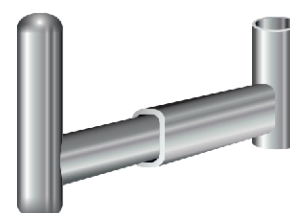



STRUMENTARIO CHIRURGICO

SURGICAL INSTRUMENTS

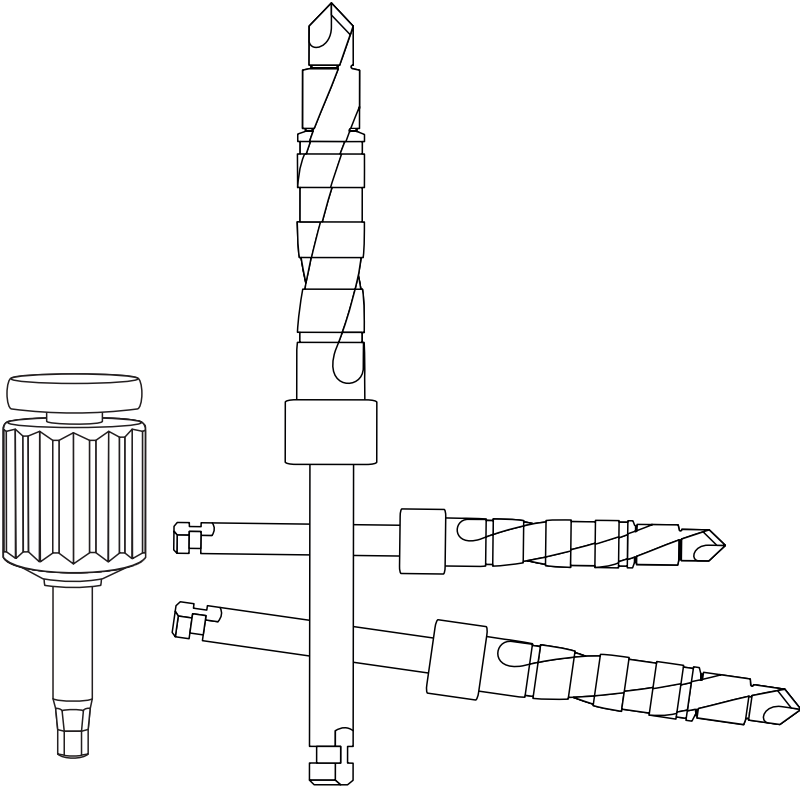

Frese Chirurgiche Hbm - Hard Bone Management Surgical Drills



07001604 Cortical Drill - Ø 1.6 mm - 11 mm



04002104 Cortical Drill - Ø 2.1 mm - 11 mm



FLS2313 Lance Drill - Ø 2.3 mm - 13 mm

Frese Chirurgiche Corticali - Cortical Surgical Drills



FIS 35 Cortical Drill - Ø 3.5 mm



FIS 40 Cortical Drill - Ø 4.0 mm



FIS 45 Cortical Drill - Ø 4.5 mm



FIS 50 Cortical Drill - Ø 5.0 mm

Frese Chirurgiche Coniche - Conical Surgical Drills



ACFC22 Conical Drill - Ø 2.2 mm - Long 18 mm



ACFC28 Conical Drill - Ø 2.8 mm - Long 18 mm



ACFC34 Conical Drill - Ø 3.4 mm - Long 18 mm



ACFC38 Conical Drill - Ø 3.8 mm - Long 18 mm



ACFC45 Conical Drill - Ø 4.5 mm - Long 18 mm

surgical instruments

Frese Chirurgiche Cilindriche - Cylindrical Surgical Drills

ACFR 22 Cylindrical Drill - Ø 2.2 mm - Long 18 mm



ACFR 28 Cylindrical Drill - Ø 2.8 mm - Long 18 mm



ACFR 34 Cylindrical Drill - Ø 3.4 mm - Long 18 mm



ACFR 38 Cylindrical Drill - Ø 3.8 mm - Long 18 mm



ACFR 45 Cylindrical Drill - Ø 4.5 mm - Long 18 mm



Stop Per Frese - Surgical Drills Stopper

ACSS 85 Stop per Frese Calibrato - Long 8.5 mm



ACSS 10 Stop per Frese Calibrato - Long 10 mm



ACSS 12 Stop per Frese Calibrato - Long 12 mm



ACSS 13 Stop per Frese Calibrato - Long 13.5 mm



Mucotomi - Surgical Drills Stopper

ST M13 Manual Tissue Punche - Ø3.0mm

ST M14 Manual Tissue Punche - Ø4.1mm

ST M15 Manual Tissue Punche - Ø5.1mm

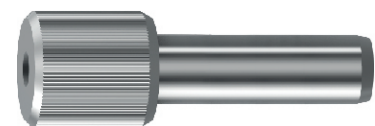

ST M23 Contrangle Tissue Punche - Ø3.0mm

ST M24 Contrangle Tissue Punche - Ø4.1mm

ST M25 Contrangle Tissue Punche - Ø5.1mm



surgical instruments



Accessori per Applicazione Manuale

Accessories for Manual Application

CD LAB Chiave Digitale da Laboratorio Es. 3,5

ALI Aiuto da Laboratorio Esagono Interno

ALE Aiuto da Laboratorio Esagono Esterno

UNADCRCAES35 Adattatore da Es. 3,5 a RA



ALI



ALE



Supporto da Laboratorio per la lavorazione dei Monconi

0°

17°

32°



Perni di Parallelismo - Titanio Gr. 5

Paralleling Pins - Titanium Gr. 5

PIN Double diameter - S 1.8mm / L 3mm - 0°

PIN17 Double diameter - S 1.8mm / L 3mm - 17°

PIN32 Double diameter - S 1.8mm / L 3mm - 32°

PIN K Kit Misuratori di Parallelismo Calibrati (10 PIN + BOX)

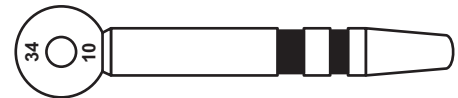

A 1.3
B 2.1
C 2.4



A 1.6
B 2.8
C 3.1



A 1.9
B 3.5
C 3.8



A 2.4
B 4.3
C 4.6

Osseo Espansori e Compattatori - Titanio Gr. 5

Bone Expanders and Compactors - Titanium Gr. 5

EXP 4 Progressive diameters

KIT 005 Expander Surgical Kit

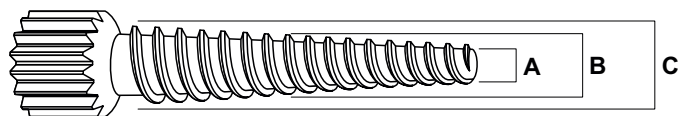

surgical instruments

PRO Sinus Lift - Mini Rialzo del Seno per via Crestale

PRO Sinus Lift - Mini Sinus Lift with Crestal Approach

Frese Taglienti 120°



PRO SL Kit Kit Completo Box + Frese + Stop + Accessori

- FC 20** Fresa ● Tagliente 120° - Ø 2.0
- FC 2026** Fresa ● Tagliente 120° - Ø 2.0/2.6
- FC 2531** Fresa ● Tagliente 120° - Ø 2.5/3.1
- FC 31P** Fresa ● Atraumatica 180° - Ø 3.1
- FC 31PTX** Fresa ● Atraumatica TaglioX 180° - Ø 3.1
- FC 31R** Fresa ● Raggiata Atraumatica - Ø 3.1
- FC 3136R** Fresa ● Raggiata Atraumatica - Ø 3.1/3.6

- KIT ST** 6 Titanium Drill Stoppers (6.0/7.0/8.5/10/11.5/13)
- STP KIT** 11 Titanium Drill Stoppers (1.0/2.0/3.0/4.0/5.0/6.0/7.0/8.5/10/11.5/13)
- ST** Titanium Drill Stopper 1 pz. (Es. ST1, ST2, ST3)



Frese Atraumatiche (Max 100 rpm)



Frese Raggiate (Max 80 rpm)



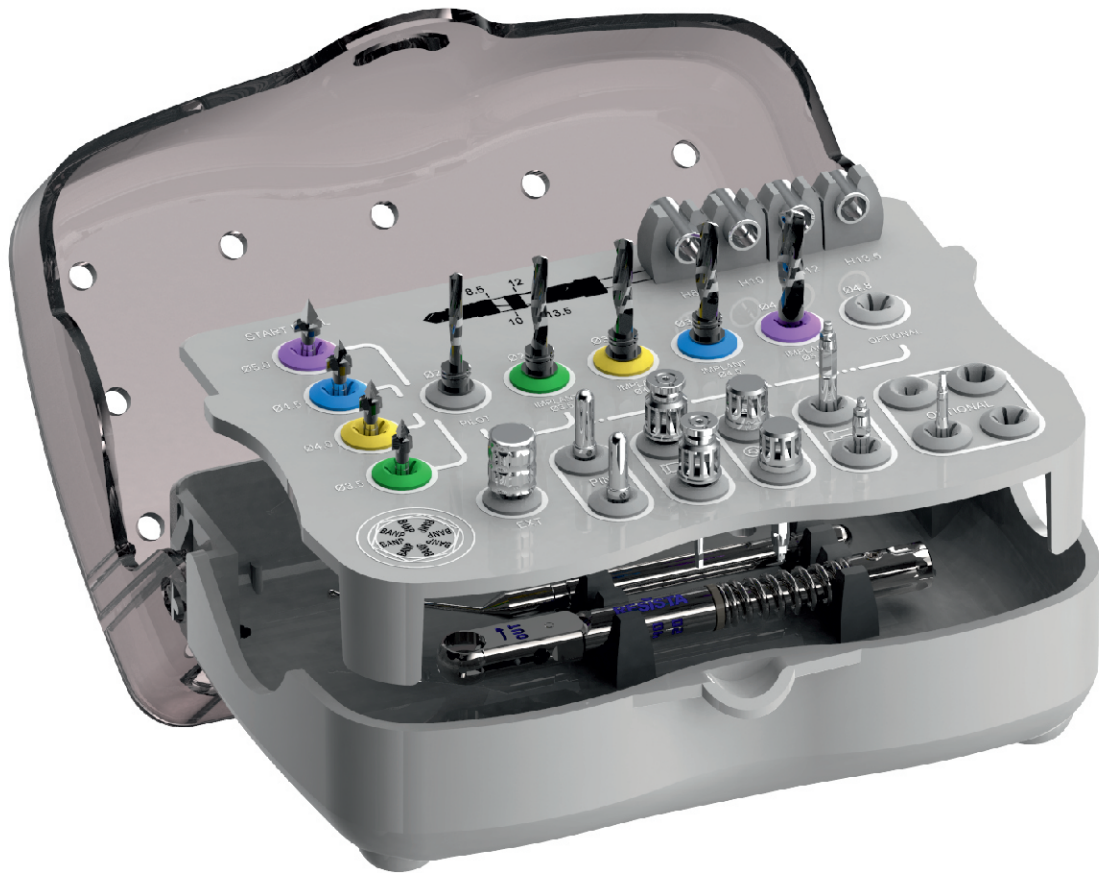

la nostra esperienza
è la tua ricchezza

Kit Chirurgici - Surgical Kits

KITBNMLK BASE Frese Coniche (9 Frese, 4 Stop, 1 Ext., 1 Driver, 2 Avvitatori, 2 Pin, 1 Cricchetto Dinam.)

KITBNMLKG GOLD Frese Coniche (9 Frese, 4 Stop, 1 Ext., 3 Driver, 4 Avvitatori, 2 Pin, 1 Cricchetto Dinam., 1 Sonda)

KITBNMLC BASE Frese Cilindriche (9 Frese, 4 Stop, 1 Ext., 1 Driver, 2 Avvitatori, 2 Pin, 1 Cricchetto Dinam.)

KITBNMLCG GOLD Frese Cilindriche (9 Frese, 4 Stop, 1 Ext., 3 Driver, 4 Avvitatori, 2 Pin, 1 Cricchetto Dinam., 1 Sonda)

instruments and tools

Cacciaviti Manuali - Manual Screw Drivers

DMRP120S	Hexagonal 1.20 - Short			
DMRP120L	Hexagonal 1.20 - Long			
ACESTR	Estrattore Protesico - Prosthetic Extractor			
DM T6DS	T6 Angled Torx Driver - 15mm			
DMEQ	Equator Squared - Short - 15mm			

Cacciaviti Da Contrangolo - Contra-angle Screw Drivers

ACDRCA	Hexagonal 1.20 - Short			
ACDRCL	Hexagonal 1.20 - Long			
DC T6DS	T6 Angled Torx Driver			
DCEQ	Equator Squared - Medium			
DCX 01	Torx - Short			
DCX 02	Torx - Long			

instruments and tools

Cacciaviti Pilastro Toronto Diritto - Straight Toronto Abutment Drivers



DCM

Contra-angle Driver



MU10AM

Manual Driver

Avvitatori per Impianto - Implant Drivers



ACMOCA

Contra-angle Driver Short



ACMOCL

Contra-angle Driver Long

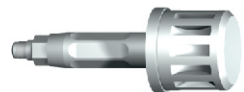

ACMOMC

Manual Driver Short

ACMOML

Manual Driver Long

Cricchetti per Implantologia - Implantology Ratchets

ACCRFI

Standard Ratchet



CRDP 2

10 - 70 Ncm - Torque Control Ratchet



Sonda Millimetrata - Millimeter Probe



SOMB

Sonda Chirurgica in Titanio
Titanium Surgical Probe



Ing. C. A. Issoglio & C. S.r.l.

Via F.lli Di Dio, 68 - 28887 Omegna (VB) - ITALIA

Tel. +39.0323.828.004 - Fax +39.0323.828.914

www.resista.it - info@resista.it

REV 03 - 03/10/2024